



Installation Instructions

CYLINDER HEAD MODIFICATION KIT FOR THE TU-FLO® 550 AND 750 COMPRESSORS

GENERAL

The Cylinder Head Modification Kit contains all the components necessary when replacing the cylinder head of Tu-Flo 550 and Tu-Flo 750 compressors.

IMPORTANT! PLEASE READ AND FOLLOW THESE INSTRUCTIONS TO AVOID PERSONAL INJURY OR DEATH:

When working on or around a vehicle, the following general precautions should be observed at all times.

1. Park the vehicle on a level surface, apply the parking brakes, and always block the wheels.
2. Stop the engine when working around the vehicle.
3. If the vehicle is equipped with air brakes, make certain to drain the air pressure from all reservoirs before beginning ANY work on the vehicle.
4. Following the vehicle manufacturer's recommended procedures, deactivate the electrical system in a manner that removes all electrical power from the vehicle.
5. When working in the engine compartment the engine should be shut off. Where circumstances require that the engine be in operation, EXTREME CAUTION should be used to prevent personal injury resulting from contact with moving, rotating, leaking, heated, or electrically charged components.
6. Never connect or disconnect a hose or line containing pressure; it may whip. Never remove a component or plug unless you are certain all system pressure has been depleted.
7. Never exceed recommended pressures and always wear safety glasses.
8. Do not attempt to install, remove, disassemble or assemble a component until you have read and thoroughly understand the recommended procedures. Use only the proper tools and observe all precautions pertaining to use of those tools.
9. Use only genuine Bendix replacement parts, components, and kits. Replacement hardware, tubing, hose, fittings, etc. should be of equivalent size, type, and strength as original equipment and be designed specifically for such applications and systems.
10. Components with stripped threads or damaged parts should be replaced rather than repaired. Repairs requiring machining or welding should not be attempted unless specifically approved and stated by the vehicle or component manufacturer.
11. Prior to returning the vehicle to service, make certain all components and systems are restored to their proper operating condition.

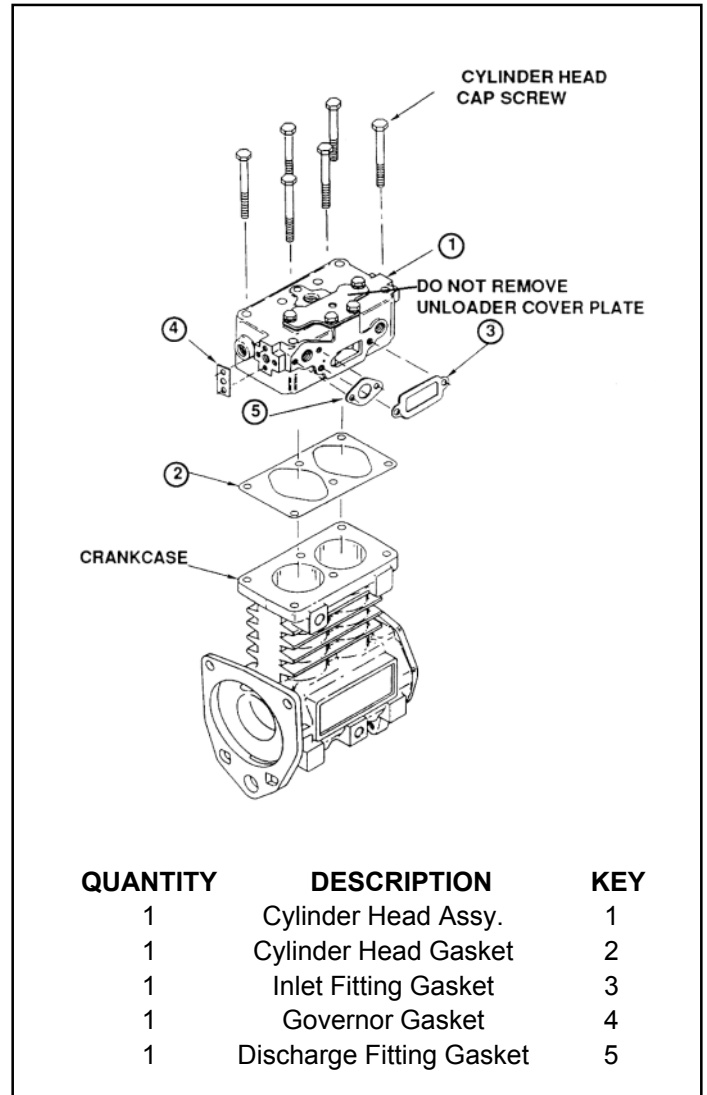

Figure 1 - Exploded View

PREPARATION FOR DISASSEMBLY

1. Remove road dirt and grease from the exterior of the compressor with a cleaning solvent.
2. Before the cylinder head is removed, mark the crankcase in relation to the cylinder head. A convenient method to indicate the above relationship is to use a metal scribe to mark the parts with numbers or lines. Do not use marking methods such as chalk that can be wiped off or obliterated during rebuilding.

REMOVAL AND DISASSEMBLY

These instructions are intended to be a guide, in some cases additional preparations and precautions may be necessary. Please see General Precautions on Page 1.

1. Block the wheels of the vehicle and drain the air pressure from all the reservoirs in the system.
2. Drain the engine cooling system and the cylinder head of the compressor. Identify and disconnect all air, water and oil lines leading to the compressor.
3. Remove the governor and any supporting bracketry attached to the compressor and mark their positions on the compressor to aid in reassembly.
4. Remove the discharge and inlet fittings, if applicable, and note their position on the compressor to aid in reassembly.
5. Before removing the cylinder head, drain the coolant from the compressor head. This is done to avoid the leakage of coolant into the compressor cylinder bores. This can be done by applying shop air to one of the water ports after the coolant lines are disconnected. Although it is not necessary to remove the compressor to service with this kit, the compressor can be removed by removing the oil lines and the flange or base mounting bolts.
6. Remove the six cylinder head cap screws and tap the head with a soft mallet to break the gasket bonding.

CLEANING

1. Taking care not to damage the crankcase, carefully scrape off any residual gasket material with a scraper. Make sure that no foreign matter enters the crankcase, since particles could lodge between the clearance of the bore and piston.
2. If necessary, clean the top of the pistons in a similar manner to remove any deposited carbon.
3. All parts should be cleaned in a good commercial grade of solvent and dried prior to inspection.

INSPECTION

Inspect the crankcase for cracks or damage. If conditions are found that would prevent the Cylinder Head Gasket(2) from properly sealing, replace the compressor.

ASSEMBLY

General Note: All torques specified in this manual are assembly torques and typically can be expected to fall off after assembly is accomplished. **Do not retorque** after initial assembly torques fall unless instructed otherwise.

To convert inch pounds of torque to foot pounds of torque, divide in pounds by 12. (inch pounds ÷ 12 = foot pounds.)

To convert foot pounds of torque to inch pounds of torque, multiply foot pounds by 12. (foot pounds x 12 = inch pounds.)

1. Lay the new Cylinder Head Gasket (2) in place aligned with the screw holes. Note that the gasket included in this kit can be installed either way up.
2. Install the Cylinder Head(1) and cap screws.

3. Torque the cap screws to an initial 200 inch-pounds and then to 440 to 500 inch-pounds using a cross pattern across the head until all screws are within the torque specification.
4. Re-torque the unloader cover cap screws to 175-225 in. lbs.
5. Reinstall the inlet and discharge fitting and the governor using their corresponding gaskets which are contained in this kit, items 3, 5 and 4 respectively.
6. Torque the mounting screws to 175-225 inch pounds.
7. If the compressor was removed, reinstall on the vehicle. Connect all air water and oil lines to their appropriate ports as marked in the disassembly procedure. If required, see Bench Testing section below, otherwise start the engine and test fittings and gaskets for leakage using a soap solution. A one-inch bubble in 5 seconds is permitted.

If additional service information is needed refer to the appropriate compressor service manual (SD-01-333 for the TF-550, or SD-01-344 for the TF-750.)

BENCH TESTING (IF REQUIRED)

Bench tests are not compulsory if the unit has been carefully rebuilt by an experienced technician.

In order to test a compressor under operating conditions, a test rack for correct mounting, cooling, lubricating, and driving the compressor is necessary. Such a compressor efficiency or build-up test can be run as follows:

An engine lubricated compressor must be connected to an oil supply line of at least 15 P.S.I. pressure during the test and an oil return line must be installed to keep the crankcase drained.

Connect to the compressor discharge port, a reservoir with a volume of 1,500 cubic inches, including the volume of the connecting line. With the compressor operating at 2,100 R.P.M., the time required to raise the reservoir(s) pressure from 85 psi to 100 psi should not exceed 7 seconds for the TU-FLO 550 or 5 seconds for the TU-FLO 750. During this test, the compressor should be checked for gasket leakage and noisy operation, as well as unloader operation and leakage.

If the compressor functions as indicated reinstall on the vehicle connecting all lines as marked during the disassembly procedure.

