

# CYCLONE DURADRAIN™ TRAILER WATER SEPARATOR

OE & SERVICE PIECE  
NUMBERS

CATALOG  
**08-A-37**

## DESCRIPTION

The Bendix® Cyclone DuraDrain™ trailer water separator can be installed in the trailer control and/or in the supply line near the gladhand. As air enters the Cyclone DuraDrain™ separator a cyclonic action separates out water and particulates, removing more than 95% of the water that passes through it. The removal of water and contaminants reduces brake drag and improves the life of the trailer system components.

Weight 0.6 lbs.  
Device Code 2402  
For service information see SD-08-2402.

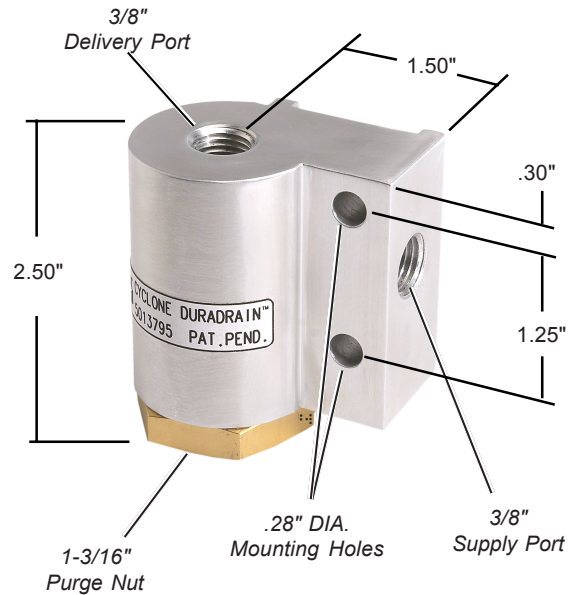

See Catalog Page 08-A-38 for Maintenance Kits

Serv. Pc. No.	O.E. Pc. No.
801747	5013821

## SYSTEM APPLICATION

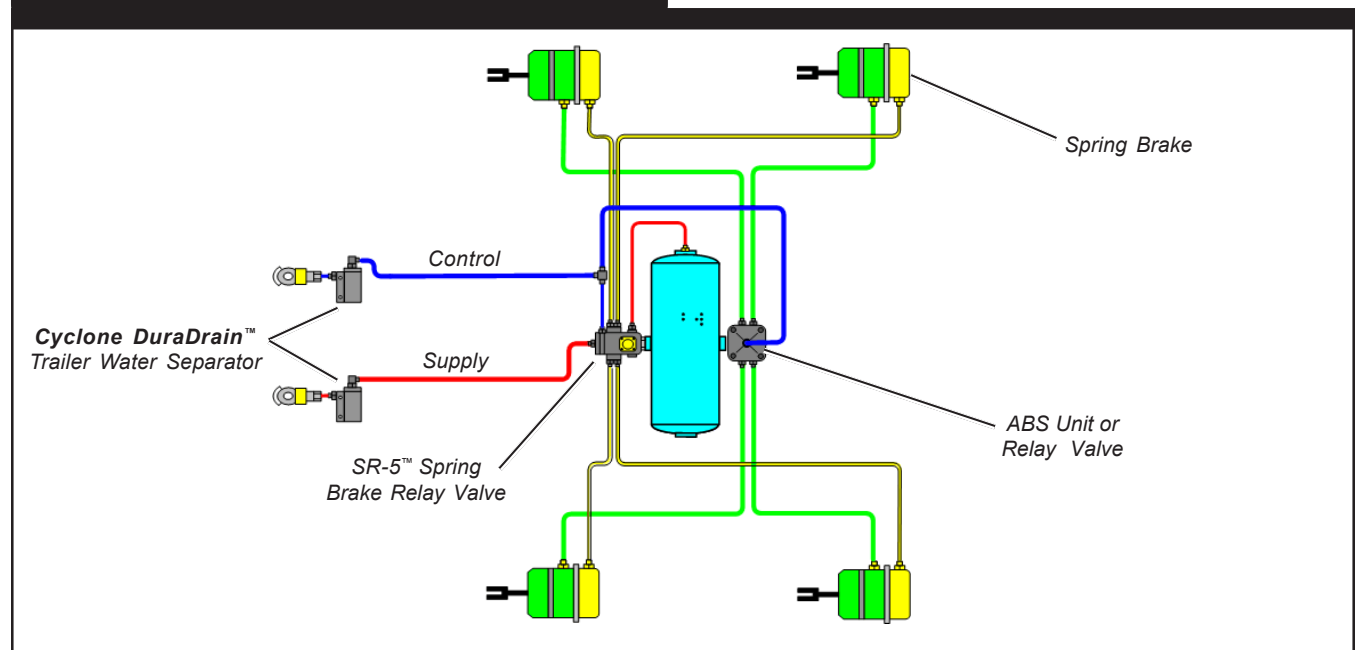

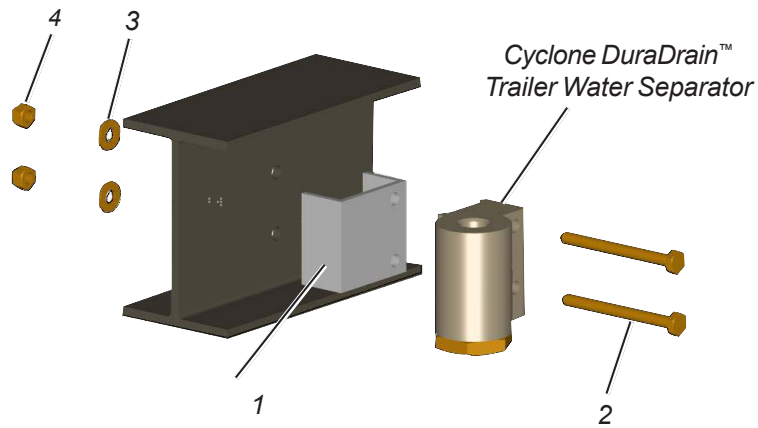

Spacer Kit piece no. 5014792 consists of the following:

Item	Description	Qty.
1	Mounting Spacer	1
2	1/4" Cap Screw	2
3	1/4" Washer	2
4	1/4" Locknut	2

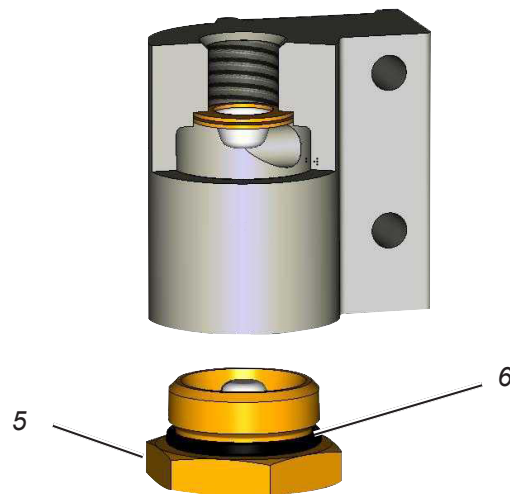

Purge Nut Kit piece no. 5013824 consists of the following:

Item	Description	Qty.
5	Purge Nut	1
6	O-ring	1
	Lubricant (not shown)	1