



Air Brake Component Identification

1 1 Dash Valves

PP-1® SD-03-3611
PP-5™ SD-03-3611
PP-7™ SD-03-3617
PP-8™ SD-03-3611
MV-3® SD-03-3415
PP-DC® SD-03-3619
RD-3 SD-03-3611
TW-1™ SD-03-3602

• MV-3®, PP-5™ & PP-DC® available in service new only.
• PP-1® and PP-7™ available in service new and remanufactured exchange.

5 Limiting Quick Release Valves

LQ-2™ SD-03-950
LQ-4™ SD-03-951
LQ-5™ SD-03-953

• Available in service new and remanufactured exchange.

11 11 Tractor Protection Valves

TP-3® SD-03-3652
TP-3DC™ SD-03-3656
TP-5™ SD-03-3655

• Available in service new and remanufactured exchange.

15 15 15 Relay Valves

R-12® SD-03-1064
R-12DC® SD-03-1068
R-14® SD-03-1064
BP-R1® SD-03-1067

• Available in service new and remanufactured exchange.

23 Tire Pressure Monitoring Systems

Sensor/Transmitter BW2799
Receiver ECU BW2799
Antenna BW2799
Display BW2799
Trailer-Link ECU BW2920

• Available in service new only.

22 Radar Systems & Cameras

AutoVue® 3G Camera SD-64-4976
AutoVue® 3G ECU SD-61-4933
BlindSpotter® Radar SD-64-20124
Wingman® Fusion® FLC-20™ Camera SD-61-4962
Wingman® FLR-10™ Radar SD-61-4960
Wingman® FLR-20™ Radar SD-61-4960
SafetyDirect® Web Portal Processor SD-65-21025
VORAD® VS-400 Radar BW2771

• Available in service new only.

2 Quick Release Valves

QR-1® SD-03-901
QR-1C® SD-03-904
QRN™ SD-03-905
QR-L™ SD-03-906

• QRN™ and QR-L™ available in service new only.
• QR-1® and QR-1C® available in service new and remanufactured exchange.

3 Compressor Components

D-2® SD-01-503
D-2A™ TCH-001-056 (Tech Bulletin)
ICV™ SD-01-3408
IRV™ SD-01-3408

• D-2® and D-2A™ available in service new and remanufactured exchange.
• IRV™ & ICV™ available in service new only.

4 Compressors

BA-921® SD-01-1327 and SD-01-690
BA-922® SD-01-700
BX-2150™ SD-01-331
DuraFlo 596™ SD-01-670
Tu-Flo® 400 Tu-Flo® 500 SD-01-326 SD-01-335
Tu-Flo® 501 SD-01-337
Tu-Flo® 550 SD-01-333
Tu-Flo® 750 SD-01-344
Tu-Flo® 1000 SD-01-326

• Available in service new and remanufactured exchange.

6 Hand Trailer Control Valves

TC-2™ SD-03-813
TC-6™ SD-03-821
TC-7™ SD-03-824
TCS-9000™ SD-03-3674

• TC-2™ available in service new and remanufactured exchange.
• TC-6™, TC-7™ and TCS-9000™ available in service new only.

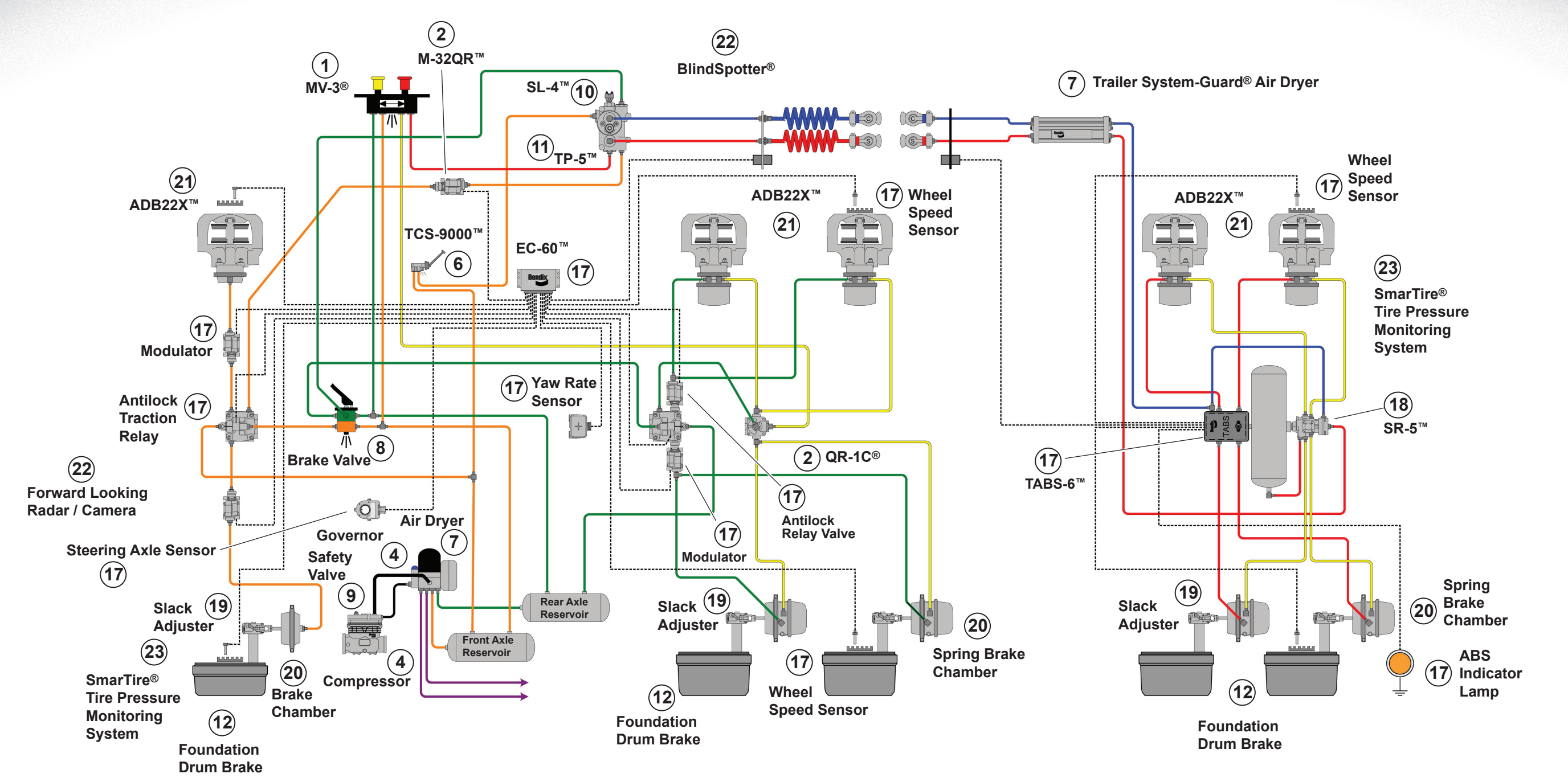

TRUCKS AND TRUCK TRACTORS:

- Charging (Black)
- Primary (Green)
- Secondary (Orange)
- Red (Supply) (Red)
- Parking (Control) (Yellow)
- Accessories (Purple)

TRAILERS:

- Trailer (Supply) (Red)
- Trailer (Control) (Blue)
- Trailer (Park) (Yellow)

The color coding of the brake system schematic follows TMC Recommended Practice #423

For additional information contact the Bendix® Tech Team at 1-800-AIR BRAKE (1-800-247-2725) or visit bendix.com or foundationbrakes.com

Reference Literature (available online)
 BW1114 Quick Reference Catalog
 BW5057 Air Brake Handbook

Air disc & drum brakes combined on a single axle are shown for pictorial purposes only.
 --- Indicates electrical connection.
 Service Data Sheet numbers are shown for reference where applicable.

Specify genuine Bendix® replacement parts every time you service your air brake system.

- All genuine Bendix replacement parts are manufactured to meet original OE specifications to guarantee quality, reliability, and proper operating performance.
- Rely on genuine Bendix replacement parts to keep your air brake system operating efficiently.
- With thousands of authorized Bendix parts outlets across North America, you're never far from quality genuine Bendix Replacement parts.

17 17 Antilock/Traction Stability Components

ATR-1™ SD-13-4811
ATR-2™ SD-13-4812
ATR-3™ SD-13-4861
ATR-6™ SD-13-4861
M-32QR™ SD-13-4870
M-32™ SD-13-4870
Modulators SD-13-4870
Modulators SD-13-4958
AT-3™ Valve N/A
EC-30™ ECU SD-13-4815
Standard EC-60™ Frame Mount ECU SD-13-4863
Premium EC-60™ Frame Mount ECU SD-13-4863
M-40QR™ SD-13-4958
M-40HF™ SD-13-4958
Standard EC-60™ Cab Mount ECU SD-13-4863
Premium EC-60™ Cab Mount ECU SD-13-4869
Advanced EC-60™ Cab Mount ECU SD-13-4869
ABS EC-80™ Cab Mount ECU SD-13-4883
ATC EC-80™ Cab Mount ECU SD-13-4883
ESP EC-80™ Cab Mount ECU SD-13-4986
SAS-60™ Steering Angle Sensor SD-13-4869
SAS-70X™ Steering Angle Sensor N/A
TABS-6™ Trailer ABS SD-13-4767
BR9235™ ABS Modulator/Relay Valve N/A
TABS-6™ Advanced Trailer ABS SD-13-4767
TABS-6™ Advanced Multi-Channel Trailer ABS SD-13-4767
Trailer Information Module (TIM™) BW2867
WS-24™ Wheel Speed Sensor SD-13-4860
YAS-60™ Yaw Rate/Lateral Acceleration Sensor SD-13-4869
YAS-70X™ Yaw Rate/Lateral Acceleration Sensor SD-13-4869

• Available in service new only.

7 Air Treatment

AD-2® SD-08-2403
AD-9®/AD-9 PG SD-08-2412
AD-9si® SD-08-2433
AD-IP® SD-08-2414
AD-IS® SD-08-2418
AD-SP®/AD-RP™ SD-08-2415 SD-08-2415A

EverFlow® Assembly available in AD-9®, AD-IP® and AD-IS® Air Dryer configurations SD-08-2417 (AD-IS air dryer)
Dryer Reservoir Module SD-98-9808
Trailer System-Guard® Air Dryer SD-08-2416
PuraGuard® QC SD-08-187B

• AD-SP®, AD-2®, AD-9®, AD-IP® and AD-IS® available in service new and remanufactured exchange.

16 Trailer/Dolly Relay Valves

R-6™ SD-03-1060
RE-6®/RE-6NC™ SD-03-1151
R-12P™ SD-03-1063

• Available in service new and remanufactured exchange.

10 10 10 10 Check Valves and Stop Light Switches

DC-4® SD-03-2202
SC-3™ SD-03-2205
SL-4™ SD-06-1800

• DC-4®, SC-3™ and SL-4™ available in service new only.

24 Solenoid Valves

FCS-9700™ SD-03-10433
SMS-9700™ SD-03-10432

• Available service new only.

Log-on and Learn from the Best
 On-line training that's available when you are—24/7/365
 Visit brake-school.com

14 14 Miscellaneous Components

DV-2™ SD-03-2501
LP-2™ SD-06-1600
LP-3™ SD-03-2010
PR-2™ SD-03-2010
PR-3™/PR-4™ SD-03-2010
RV-3™ SD-03-3515
SS-1™ SD-03-4010
SV-1™ SD-03-4020
TR-3™ SD-03-4650

• Available in service new only.
• DV-2™ available in service new and remanufactured exchange.

20 Actuators

Brake Chamber SD-02-1302
EnduraSure™ Spring Brake Chamber SD-02-4525

• Available in service new only.

Diagnostic Tools

ACom® Diagnostic Software (Download for latest version at bendix.com)
RDU™
TRDU™ with Adapter
Wingman® ACB Radar Alignment Tool SD-13-3333
SmarTire® Maintenance Tool BW2809
SmarTire® LF Tool BW2820

• Available in service new only.

8 8 Brake Valves—Foot Operated

E-6® SD-03-817
E-7™ SD-03-818
E-8P® SD-03-830
E-10™ SD-03-817
E-10P™ SD-03-830

• E-6®, E-7™, and E-8P® available in service new and remanufactured exchange.
• E-10™ and E-10P™ available in service new only.

9 Safety Valves

ST-3™ (Not used on compressors or AD-IS® air dryers.) SD-03-1901
ST-4™ TCH-001-040 TCH-001-064 SD-03-1901

• Valves available in service new only.

13 13 13 Spring Brake Valves

R-7™ SD-03-4504
SR-1™ SD-03-4508
SR-7® SD-03-9043

• SR-1™ and R-7™ available in service new and remanufactured exchange.
• SR-7® available in service new only.

18 Trailer Spring Brake Valves

SR-5™ SD-03-4516
SRC-7000™ SD-03-4656

• SR-5™ available in service new and remanufactured exchange.
• SRC-7000™ available in service new only.

19 Slack Adjusters

Versajust® Automatic SD-05-4630
Manual SD-05-1200

• Available in service new only.

21 Air Disc Brake

ADB22X™ SD-23-7541
ADB22X™-LT BW7587

• Available in OE only.

12 Foundation Drum Brake

High Performance ES Brakes™ Extended Service Vehicle Brakes (Reduced Stopping Distance) N/A
ES Brakes™ Extended Service Vehicle Brakes BW7258

• Available in OE only.