



Installation Instructions

KIT PC. NO.
107515

UNLOADER MAINTENANCE KIT FOR THE TU-FLO 550/750 COMPRESSOR

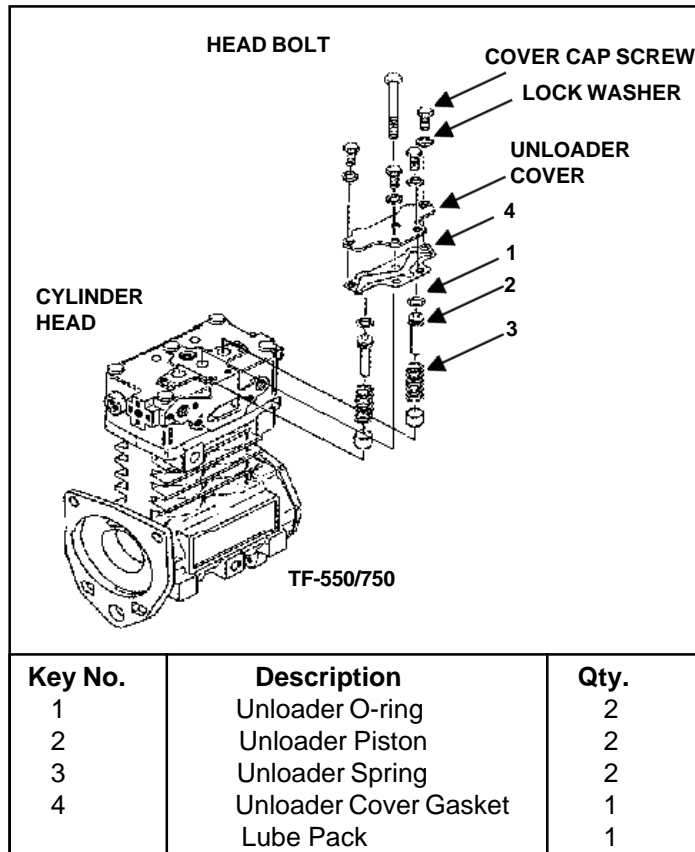

Figure 1

IMPORTANT! PLEASE READ AND FOLLOW THESE INSTRUCTIONS TO AVOID PERSONAL INJURY OR DEATH:

When working on or around a vehicle, the following general precautions should be observed at all times.

1. Park the vehicle on a level surface, apply the parking brakes, and always block the wheels.
2. Stop the engine when working around the vehicle.
3. If the vehicle is equipped with air brakes, make certain to drain the air pressure from all reservoirs before beginning ANY work on the vehicle.
4. Following the vehicle manufacturer's recommended procedures, deactivate the electrical system in manner that removes all electrical power from the vehicle.
5. When working in the engine compartment the engine should be shut off. Where circumstances require that the engine be in operation, **EXTREME CAUTION** should be used to prevent personal injury resulting from contact with moving, rotating, leaking, heated, or electrically charged components.

6. Never connect or disconnect a hose or line containing pressure; it may whip. Never remove a component or plug unless you are certain all system pressure has been depleted.
7. Never exceed recommended pressures and always wear safety glasses.
8. Do not attempt to install, remove, disassemble or assemble a component until you have read and thoroughly understand the recommended procedures. Use only the proper tools and observe all precautions pertaining to use of those tools.
9. Use only genuine Bendix replacement parts, components, and kits. Replacement hardware, tubing, hose, fittings, etc. should be of equivalent size, type, and strength as original equipment and be designed specifically for such applications and systems.
10. Components with stripped threads or damaged parts should be replaced rather than repaired. Repairs requiring machining or welding should not be attempted unless specifically approved and stated by the vehicle or component manufacturer.
11. Prior to returning the vehicle to service, make certain all components and systems are restored to their proper operating condition.

PREPARATION FOR DISASSEMBLY

Remove road dirt and grease from the exterior of the compressor with a cleaning solvent before the unloader cover is removed.

Remove the head bolt that secures the unloader cover, the unloader cover cap screws, lockwashers and unloader cover plate. Scrape off any gasket material from the unloader cover plate and cylinder head.

1. Remove and discard the unloader pistons(2), o-rings(1) and springs(3).
2. Inspect the unloader piston bushing for nicks, wear, corrosion and scoring. It is recommended that the compressor be replaced if it is determined that the unloader bushing is damaged or worn excessively.

ASSEMBLY

Apply lubricant provided to the unloader piston o-rings. Install the unloader springs(3) and the unloader piston and o-ring assemblies in their bores being careful not to cut the o-rings. Install the unloader cover gasket(4) and unloader cover plate and secure the four cover cap screws and lock washers. Snug the cap screws prior to tightening to 175-225 in. lbs. in a cross pattern. Install the head bolt and torque to 440-500 in. lbs. Re-torque the unloader cover cap screws to 175-225 in. lbs.

TESTING THE COMPRESSOR

Connect to the compressor discharge port, a reservoir with a volume of 1500 cubic inches, including the volume of the connecting line. With the compressor operating at 2100 R.P.M., the time required to raise the reservoir(s) pressure from 85 psi to 100 psi should not exceed 7 seconds for the TU-FLO 550 and 5 seconds for the TU-FLO 750 compressor. During this test, the compressor should be checked for gasket leakage and noisy operation, as well as unloader operation and leakage.

If additional service information is needed refer to the appropriate compressor service manual.