



Service Data

SD-03-3611

Bendix® PP-1®, PP-2™, PP-5™, PP-8™, & RD-3™ Push-Pull Type Control Valves

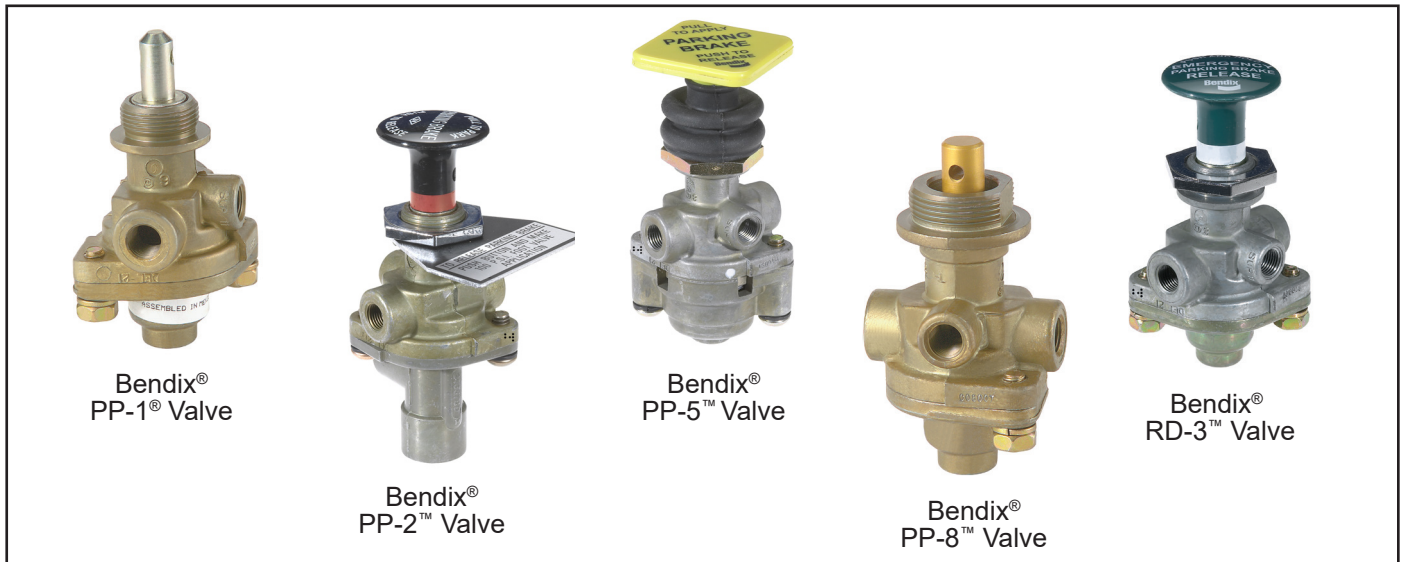

Figure 1 – Push-Pull Type Control Valves

DESCRIPTION

The PP valves are push-pull manually operable on-off air control valves with an exhaust function. Most are pressure sensitive, so that they will automatically move from the applied to the exhaust position as supply pressure is reduced to a certain minimum, depending on the spring installed. The exception to this is the Bendix® PP-8™ valve and some Bendix® PP-1® valves which do not contain a spring. The PP-8 valve also has a larger diameter shaft for button mounting so that when installed on the same panel with other PP valves the buttons cannot be inadvertently mixed. The PP-8 valve is normally used to operate tractor spring brakes independently from the trailer.

The Bendix® PP-5™ valve is unique in having an auxiliary piston in the lower cover which, upon receiving a pneumatic signal of 18 psi or more, will cause the valve to move from the applied to the exhaust position from a 100 psi application.

The Bendix® RD-3™ valve differs slightly in that it normally remains in the exhaust position and requires a constant manual force to hold it in the applied position.

The Bendix® PP-2™ valve has an auxiliary port which may be plumbed into a service brake line to release the spring brakes if a service application is made, preventing compounding of forces on the foundation brakes.

PURPOSE OF THIS MANUAL

This document is intended to act as a source of maintenance information to those involved in servicing Bendix® push-pull type control valves.

ADDITIONAL SUPPORT

For additional service information, contact the Bendix Tech Team online at techteam@bendix.com, or by calling 1-800-AIR-BRAKE (1-800-247-2725), option 2. Tech Team members are available Monday through Thursday, 8:00 a.m. to 6:00 p.m. and Friday, 8:00 a.m. to 5:00 p.m. ET.

GENERAL SAFETY GUIDELINES



WARNING! PLEASE READ AND FOLLOW THESE INSTRUCTIONS



TO AVOID PERSONAL INJURY OR DEATH:

When working on or around a vehicle, the following guidelines should be observed **AT ALL TIMES**:

- ▲ Park the vehicle on a level surface, apply the parking brakes, and always block the wheels. Always wear personal protection equipment.
- ▲ Stop the engine and remove the ignition key when working under or around the vehicle. When working in the engine compartment, the engine should be shut off and the ignition key should be removed. Where circumstances require that the engine be in operation, **EXTREME CAUTION** should be used to prevent personal injury resulting from contact with moving, rotating, leaking, heated, or electrically charged components.
- ▲ Do not attempt to install, remove, disassemble, or assemble a component until you have read, and thoroughly understand, the recommended procedures. Use only the proper tools and observe all precautions pertaining to use of those tools.
- ▲ If the work is being performed on the vehicle's air brake system, or any auxiliary pressurized air systems, make certain to drain the air pressure from all reservoirs before beginning **ANY** work on the vehicle. If the vehicle is equipped with a Bendix® AD-IS® air dryer system, a Bendix® DRM™ dryer reservoir module, a Bendix® AD-9si®, AD-HF®, or AD-HFi® air dryer, be sure to drain the purge reservoir.
- ▲ Following the vehicle manufacturer's recommended procedures, deactivate the electrical system in a manner that safely removes all electrical power from the vehicle.
- ▲ Never exceed manufacturer's recommended pressures.
- ▲ You should consult the vehicle manufacturer's operating and service manuals, and any related literature, in conjunction with the Guidelines above.
- ▲ Never connect or disconnect a hose or line containing pressure; it may whip and/or cause hazardous airborne dust and dirt particles. Wear eye protection. Slowly open connections with care, and verify that no pressure is present. Never remove a component or plug unless you are certain all system pressure has been depleted.
- ▲ Use only genuine Bendix® brand replacement parts, components, and kits. Replacement hardware, tubing, hose, fittings, wiring, etc. must be of equivalent size, type, and strength as original equipment and be designed specifically for such applications and systems.
- ▲ Components with stripped threads or damaged parts should be replaced rather than repaired. Do not attempt repairs requiring machining or welding unless specifically stated and approved by the vehicle and component manufacturer.
- ▲ Prior to returning the vehicle to service, make certain all components and systems are restored to their proper operating condition.
- ▲ For vehicles with Automatic Traction Control (ATC), the ATC function must be disabled (ATC indicator lamp should be ON) prior to performing any vehicle maintenance where one or more wheels on a drive axle are lifted off the ground and moving.
- ▲ The power **MUST** be temporarily disconnected from the radar sensor whenever any tests **USING A DYNAMOMETER** are conducted on a vehicle equipped with a Bendix® Wingman® system.

PREVENTIVE MAINTENANCE

Important: Review the Bendix Warranty Policy before performing any intrusive maintenance procedures. A warranty may be voided if intrusive maintenance is performed during the warranty period.

No two vehicles operate under identical conditions, as a result, maintenance intervals may vary. Experience is a valuable guide in determining the best maintenance interval for air brake system components. At a minimum, the PP valves should be inspected every 6 months or 1500 operating hours, whichever comes first, for proper operation. Should the PP valves not meet the elements of the operational tests noted in this document, further investigation and service of the valve may be required.

REMOVAL

Block and/or hold the vehicle by a means other than air brakes and drain all reservoirs.

1. Drive the button roll-pin out with a punch and remove the button.
2. Mark each air supply line and its port for easy reinstallation, then disconnect them. Remove the valve from the panel by removing the panel mounting nut.

INSTALLATION

1. Install the valve in panel, securing with the panel mounting nut.
2. Reconnect the air lines using marks made during removal as a guide.
3. Install the operating button. Secure the operating button by installing the button roll pin.

DISASSEMBLY: BENDIX® PP-1®, PP-8™, & RD-3™ VALVES

1. Remove the two cap screws (3) which retain the lower cover and remove the cover. Remove the sealing ring (4).
2. Insert a small punch through the roll pin hole in the stem and remove the locknut (5).
3. Remove the inlet-exhaust valve (6) and plunger (7) and spring (8), if any.
4. Remove the o-ring (9) from the plunger.

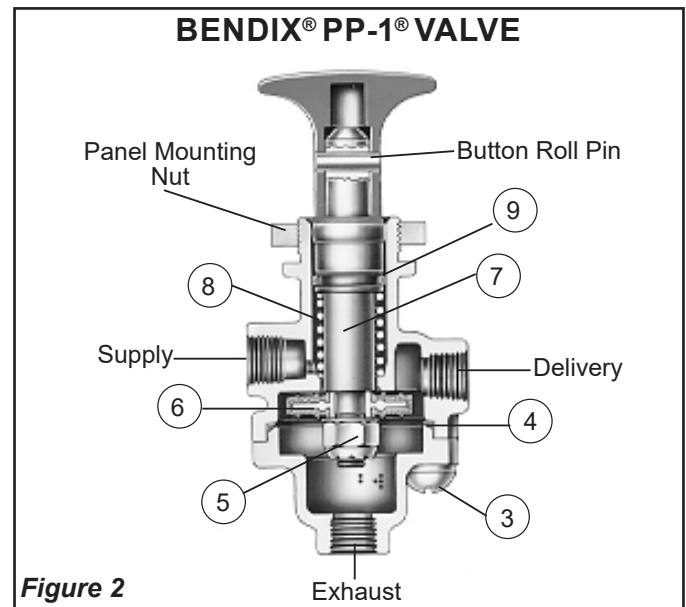

Figure 2

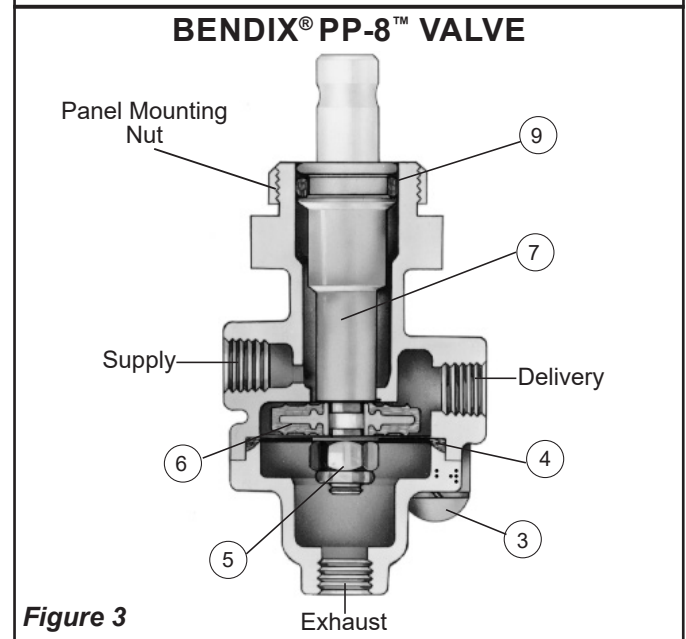

Figure 3

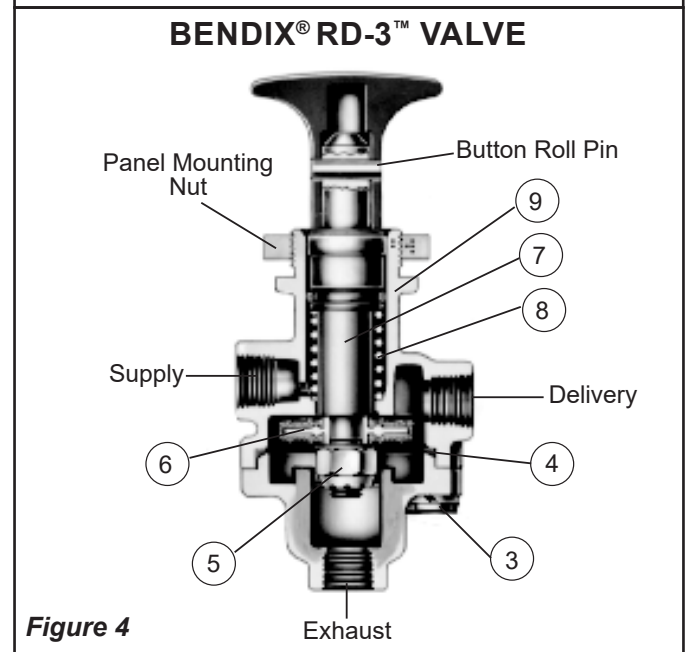
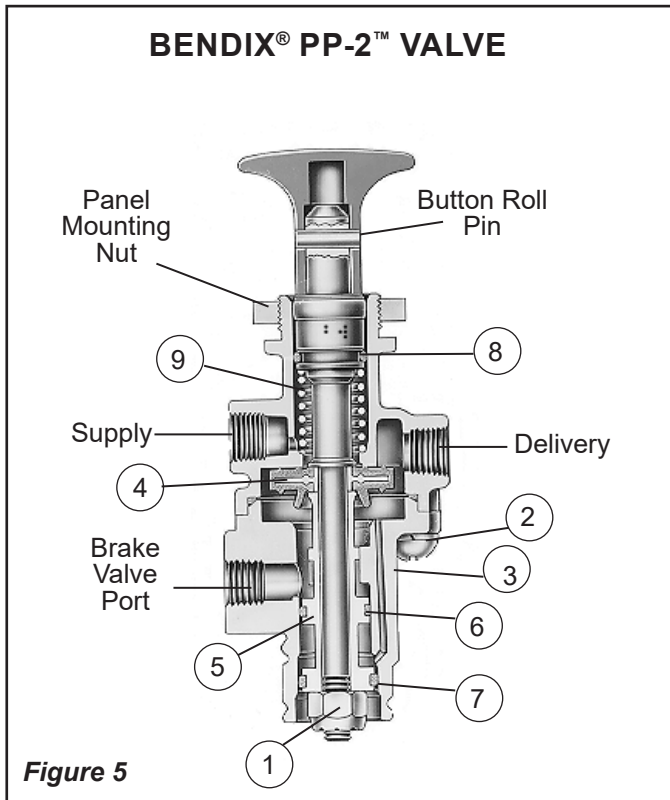

Figure 4

DISASSEMBLY: BENDIX® PP-2™ VALVE

1. Insert a small punch through the roll pin hole in the plunger and remove the locknut (1) from the plunger.
2. Withdraw the plunger and remove the spring (9) and the o-ring (8).
3. Remove the two machine screws (2) and remove the lower cover (3).
4. Remove the inlet-exhaust valve (4) and the piston (5).
5. Remove the o-rings (6 & 7) from the piston.



DISASSEMBLY: BENDIX® PP-5™ VALVE

1. Perform the same operations as for the PP-1® valve.
2. Remove the inlet seal (10), shown in Figure 6, from the lower cover. Remove the ring diaphragm (4) from the inlet seal.
3. Remove the piston (11) and the o-ring (2).

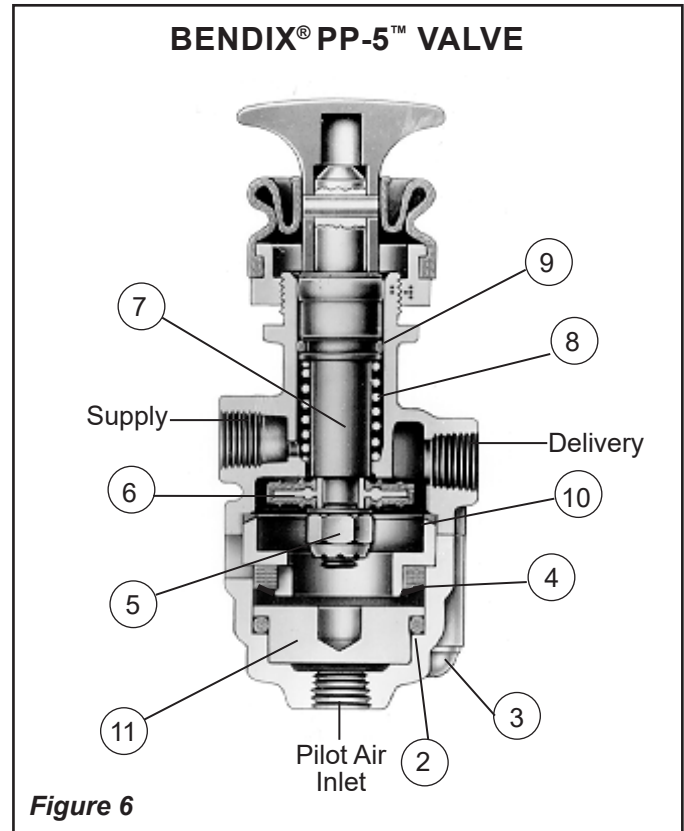

OPERATING AND LEAKAGE TESTS



Do not install fittings or tubing into the exhaust port if used for parking brake control. If a worn PP-1 or PP-8 valve is used for parking brake control and the exhaust plumbing is kinked, bent, or restricted, the vehicle might not park, and a roll away may result, potentially resulting in injury or death.

Bendix® Valve	Automatic Exhaust (psi)	Momentary Apply	Pilot Trip Feature (psi)	Non-Automatic
PP-1®	20, 30, 40 or 60	–	–	–
PP-2™	40	–	–	–
PP-5™	40, 50 or 60	–	18 or 24	–
RD-3™	–	Must be held manually	–	–
PP-8™	–	–	–	Will remain in either position

Table 1 - Push-Pull Type Control Valves Operation

BENDIX® PP-1®, PP-8™, & RD-3™ VALVES

1. Run the vehicle until the air system reaches full reservoir pressure (120-135 psi). Turn off the vehicle.
2. Move the control valve button & plunger from side to side and up and down. Do not push the button in. If there is any play, or if audible leakage is detected, the valve must be replaced.
3. Identify the dash valve exhaust hose location – if there is a hose still connected to the Park Control Valve Exhaust Port, it is advised to disconnect it and remove any fitting.
4. With the button pulled out (exhaust position), rotate the button and plunger in a clockwise direction – stopping every 90° to check for leakage.
5. Using a soap solution, check for leaks. The allowable leakage should not exceed a 1” bubble in 5 seconds at any location on the valve.
6. Push the button in (applied position) and check for leaks. (The Bendix® RD-3™ valve will have to be manually held in this position.) The leakage should not exceed a 1” bubble in 3 seconds at any location on the valve.
7. Reduce the supply pressure. At a pressure from 60 to 20 psi, depending on the part number specific automatic release pressure, the button should pop out automatically, exhausting the delivery volume. (This does not apply to the RD-3, PP-8 or some PP-1 valves without an automatic release pressure).

BENDIX® PP-5™ VALVE

1. Proceed as for Bendix® PP-1® valve through Step 4.
2. Connect a modulated source of air pressure to the pilot air inlet. With the button pushed in (applied position) with 125 psi supply pressure and a gradually increasing pressure applied at the pilot air port, the valve should move to the release position with a pilot pressure of not more than 18 psi. Leakage in this mode should not exceed a 1-in. bubble in three (3) seconds at the exhaust port and a 1-in. bubble in five (5) seconds at the plunger stem.

BENDIX® PP-2™ VALVE

1. Proceed as for the PP-1 valve through Step 1.
2. With the button pulled out (exhaust position), leakage at the brake valve port or at the plunger stem should not exceed a 1-in. bubble in five (5) seconds.
3. Push the button in. Supply pressure should be present in the delivery volume. Leakage at the exhaust port or around the plunger stem should not exceed a 1-in. bubble in five (5) seconds.
4. Pull the button out and apply supply pressure at the brake valve port. Supply pressure should be present in the delivery volume and leakage at the exhaust port should not exceed a 1-in. bubble in five (5) seconds.

NOTE: If any of the above push-pull valves do not function as described or if leakage is excessive, it is recommended they be returned to our nearest authorized distributor for a service new or remanufactured replacement.

B2BENDIX.COM
24/7/365 ACCESS
FULL SERVICE AT YOUR FINGERTIPS

TECHNICAL SUPPORT
1-800-AIR-BRAKE (1-800-247-2725)
TECHTEAM@BENDIX.COM

BRAKE-SCHOOL.COM
WEB-BASED TRAINING
LOG ON AND LEARN FROM THE BEST

