

Technical Bulletin

Bulletin No: TCH-001-050

Effective Date: 10/31/02

Cancels: N/A

Page: 1 of 1

Subject: **OVERRIDING THE D-2 GOVERNOR**

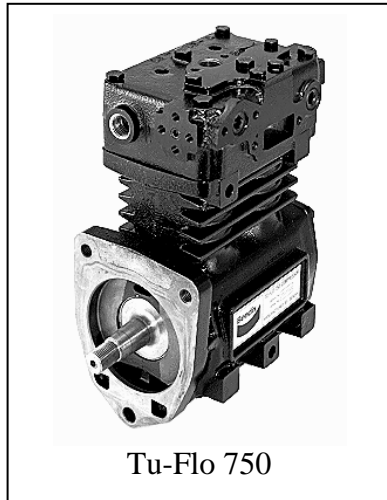

Tu-Flo 750

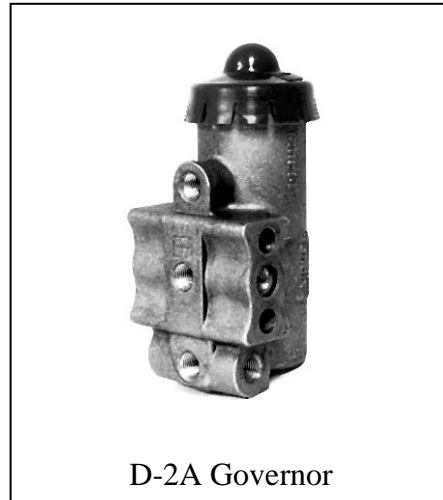

D-2A Governor

Bendix® Tu-Flo® 550 and Tu-Flo® 750 compressors are designed to operate using Bendix D-2 or D-2A governors to maintain the correct air brake system pressure.

The governor controls when the compressor runs loaded (building air mode) or unloaded (not building air mode). In the unloaded mode, part of the governor's function is to apply a controlled amount of pressure against the unloader pistons in the compressor head.

Use of non-Bendix valves to override (or instead of) the Bendix D-2 governor can cause incorrect pressure to be applied to the unloader pistons and result in broken compressor inlet valves. Broken inlet valves may puncture the compressor pistons, forcing compressed air back into the compressor, through the compressor flange and into the engine crankcase.

The installation of any valve to override the D-2 governor control is **not** recommended without prior Bendix approval. We recommend using only genuine Bendix governors.

Reference Documents

SD-01-333 Service Data Sheet for Tu-Flo 550 compressor.
SD-01-344 Service Data Sheet for Tu-Flo 750 compressor.
SD-01-503 Service Data Sheet for D-2 governor.