



Installation Instructions

AD-IP AIR DRYER BRACKET INSTALLATION

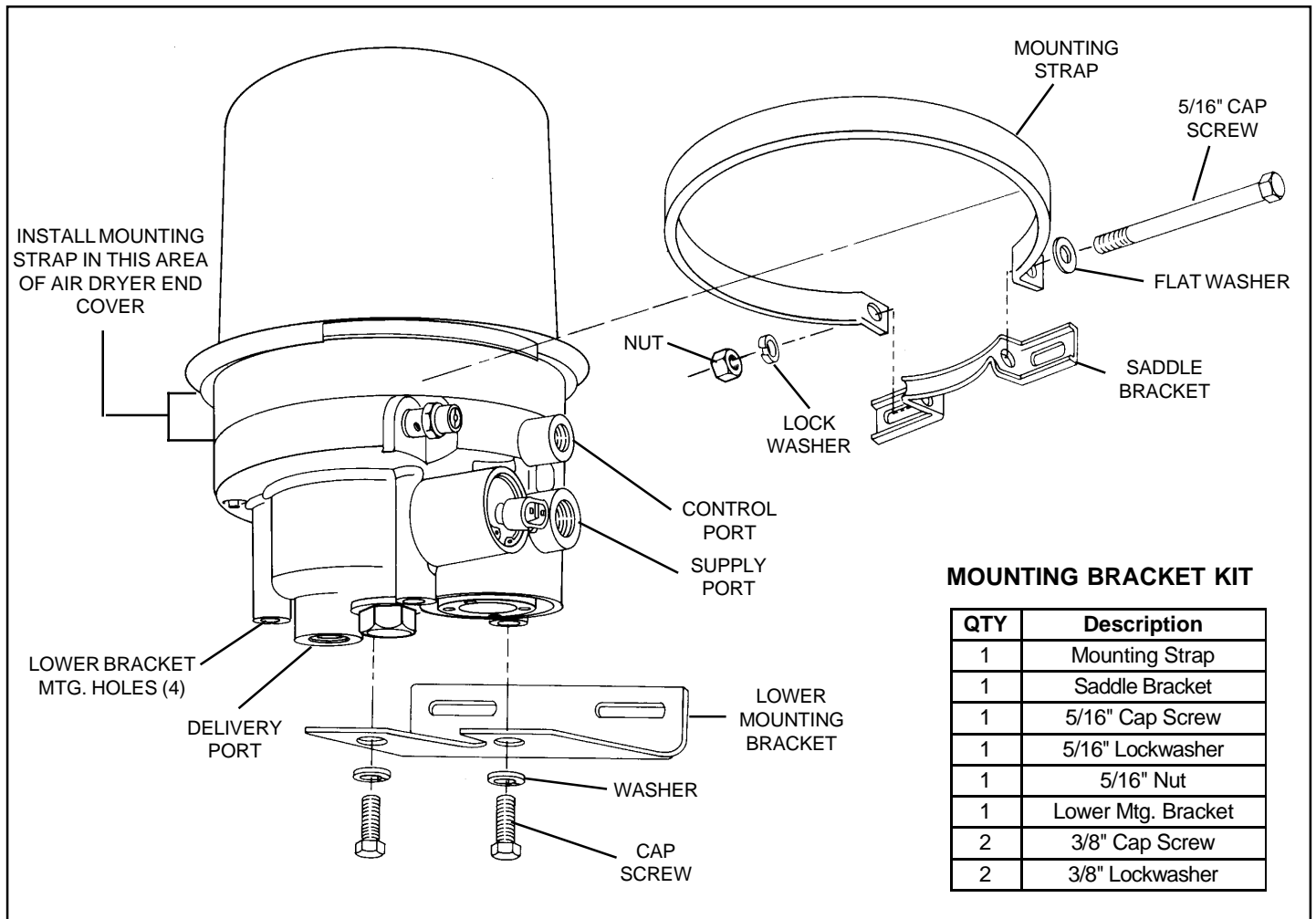

FIGURE 1

IMPORTANT! PLEASE READ AND FOLLOW THESE INSTRUCTIONS TO AVOID PERSONAL INJURY OR DEATH:

When working on or around a vehicle, the following general precautions should be observed at all times.

1. Park the vehicle on a level surface, apply the parking brakes, and always block the wheels.
2. Stop the engine when working around the vehicle.
3. If the vehicle is equipped with air brakes, make certain to drain the air pressure from all reservoirs before beginning ANY work on the vehicle.
4. Following the vehicle manufacturer's recommended procedures, deactivate the electrical system in manner that removes all electrical power from the vehicle.

5. When working in the engine compartment the engine should be shut off. Where circumstances require that the engine be in operation, **EXTREME CAUTION** should be used to prevent personal injury resulting from contact with moving, rotating, leaking, heated, or electrically charged components.
6. Never connect or disconnect a hose or line containing pressure; it may whip. Never remove a component or plug unless you are certain all system pressure has been depleted.
7. Never exceed recommended pressures and always wear safety glasses.
8. Do not attempt to install, remove, disassemble or assemble a component until you have read and thoroughly understand the recommended procedures. Use only the proper tools and observe all precautions pertaining to use of those tools.

9. Use only genuine Bendix replacement parts, components, and kits. Replacement hardware, tubing, hose, fittings, etc. should be of equivalent size, type, and strength as original equipment and be designed specifically for such applications and systems.
10. Components with stripped threads or damaged parts should be replaced rather than repaired. Repairs requiring machining or welding should not be attempted unless specifically approved and stated by the vehicle or component manufacturer.
11. Prior to returning the vehicle to service, make certain all components and systems are restored to their proper operating condition.

BRACKET INSTALLATION (FIG. 1)

1. Assemble the mounting strap and saddle bracket as illustrated.
 - A. Place the mounting strap in the end cover channel provided for it, then install the saddle bracket and secure the strap to the saddle bracket using the 5/16" cap screw, lock washer and nut provided. Do not tighten the 5/16" nut and cap screw that passes through the mounting strap and saddle bracket at this time.
2. Install the lower mounting bracket on the AD-IP air dryer. To accomplish this, it will be necessary to choose two, of the four available, mounting holes. To determine which two holes to utilize to attach the lower bracket, take into consideration the piping connections required to install the AD-IP air dryer and use those that will best position the unit for ease of installation.
 - A. Utilizing the two 3/8" cap screws and washers provided with the AD-IP air dryer, attach the lower mounting bracket and torque to 300-360 in. lbs.
3. Orient the strap and saddle bracket so that it is in a flat plane with the lower bracket. Torque the 5/16" nut to 50-100 in. lbs..

Note: For installation requirements and instructions to install the air dryer on the vehicle refer to instruction sheet packaged with the air dryer.