

# Installation Instructions



## SEAL REPLACEMENT KIT FOR BENDIX® 720CC DISCHARGE LINE UNLOADER (DLU) DOUBLE CYLINDER COMPRESSOR INSTALLED ON INTERNATIONAL® MAXXFORCE™ 11 AND 13 BIG BORE ENGINES

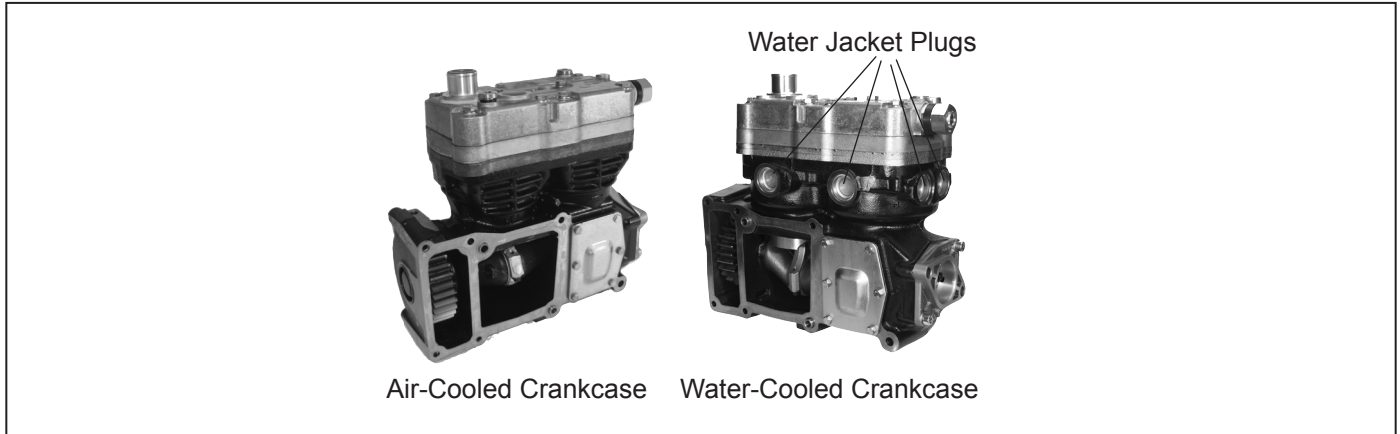

Figure 1 – Bendix® 720cc Crankcases may be Water-Cooled or Air-Cooled

Components supplied in this kit.  
Note: not all items will be used to service this compressor.

Kit Contents		Crankcase Style	
Item Key	Description	Water-Cooled	Air-Cooled
		Qty.	Qty.
A	Gasket	1	1
B	Gasket	1	1
C	Inlet Reed/Valve Gasket	1	1
D	Gasket	NR*	NR*
E	Gasket	NR*	NR*
F	Gasket	1	1
G	End Cover O-ring	1	1
H	O-ring	2	NR*
I	Discharge Reeds	NR*	NR*
J	Cover (2 supplied)	1	1
K	Plug	NR*	NR*
L	Gaskets (3 supplied)	NR*	NR*
M	Short Hex Head Bolts	2	2
N	Long Hex Head Bolts	8	8

\*NR = not used on this compressor

Figure 2 – Kit Contents

MAXXFORCE™ is a trademark of International Truck and Engine Corp.

## GENERAL SAFETY GUIDELINES



**WARNING! PLEASE READ AND FOLLOW THESE INSTRUCTIONS**



**TO AVOID PERSONAL INJURY OR DEATH:**

When working on or around a vehicle, the following guidelines should be observed **AT ALL TIMES**:

- ▲ Park the vehicle on a level surface, apply the parking brakes and always block the wheels. Always wear personal protection equipment.
- ▲ Stop the engine and remove the ignition key when working under or around the vehicle. When working in the engine compartment, the engine should be shut off and the ignition key should be removed. Where circumstances require that the engine be in operation, **EXTREME CAUTION** should be used to prevent personal injury resulting from contact with moving, rotating, leaking, heated or electrically-charged components.
- ▲ Do not attempt to install, remove, disassemble or assemble a component until you have read, and thoroughly understand, the recommended procedures. Use only the proper tools and observe all precautions pertaining to use of those tools.
- ▲ If the work is being performed on the vehicle's air brake system, or any auxiliary pressurized air systems, make certain to drain the air pressure from all reservoirs before beginning ANY work on the vehicle. If the vehicle is equipped with a Bendix® AD-IS® air dryer system, a Bendix® DRM™ dryer reservoir module, or a Bendix® AD-9si® air dryer, be sure to drain the purge reservoir.
- ▲ Following the vehicle manufacturer's recommended procedures, deactivate the electrical system in a manner that safely removes all electrical power from the vehicle.
- ▲ Never exceed manufacturer's recommended pressures.
- ▲ You should consult the vehicle manufacturer's operating and service manuals, and any related literature, in conjunction with the Guidelines above.
- ▲ Never connect or disconnect a hose or line containing pressure; it may whip and/or cause hazardous airborne dust and dirt particles. Wear eye protection. Slowly open connections with care, and verify that no pressure is present. Never remove a component or plug unless you are certain all system pressure has been depleted.
- ▲ Use only genuine Bendix® brand replacement parts, components and kits. Replacement hardware, tubing, hose, fittings, wiring, etc. must be of equivalent size, type and strength as original equipment and be designed specifically for such applications and systems.
- ▲ Components with stripped threads or damaged parts should be replaced rather than repaired. Do not attempt repairs requiring machining or welding unless specifically stated and approved by the vehicle and component manufacturer.
- ▲ Prior to returning the vehicle to service, make certain all components and systems are restored to their proper operating condition.
- ▲ For vehicles with Automatic Traction Control (ATC), the ATC function must be disabled (ATC indicator lamp should be ON) prior to performing any vehicle maintenance where one or more wheels on a drive axle are lifted off the ground and moving.
- ▲ The power **MUST** be temporarily disconnected from the radar sensor whenever any tests **USING A DYNAMOMETER** are conducted on a vehicle equipped with a Bendix® Wingman® system.

Follow all General Safety Guidelines including, but not limited to, those found on page two of this document. In many instances it may not be necessary to remove the compressor from the vehicle when installing the various maintenance kits and service parts. The Technician must assess the installation and determine the correct course of action.

These instructions are general and are intended to be a guide. In some cases additional preparations and precautions are necessary. In all cases follow the instructions contained in the vehicle maintenance manual in lieu of the instructions, precautions, and procedures presented in this document.

**Note:** The compressor seal kit was developed to support the maintenance of more than one compressor model. This installation instruction sheet supports the Bendix® 720cc (DLU)-style compressor models shown in Figure 1. The main difference between the two styles of compressors is whether the crankcase is water-cooled or air-cooled. The water-cooled crankcase requires the crankcase o-rings (H); the air-cooled version does not. Figure 1 depicts the visual difference in the two compressor models.

Refer to Figure 2 to determine which components in the service kit are appropriate to service your compressor. In addition, Figure 3 shows an exploded view of the compressor showing the service components.

## VEHICLE PREPARATION

1. Block the wheels of the vehicle and drain the air pressure from all the reservoirs in the system.
2. Drain the engine cooling system and the cylinder head of the compressor. Identify and disconnect all air, water, and oil lines leading to the compressor.
3. Remove as much road dirt and grease from the exterior of the compressor as possible.
4. Remove the discharge fitting, if applicable, and note the position on the compressor to aid in reassembly.
5. Remove any supporting brackets attached to the compressor and note their positions on the compressor to aid in reassembly.
6. **Note the position of the six mounting bolts. Two of the six bolts are shorter and must be installed in the same locations during re-assembly. Mark the bolts and locations to ensure they are returned to their original locations.** Remove the six mounting bolts that retain the compressor to the side of the engine block. Remove the compressor from the vehicle.
7. Inspect the drive gear and associated drive parts for visible wear or damage. If the compressor drive gear is worn or damaged, the compressor must be replaced. Refer to the Engine Manufacturer's service manual to address the associated engine drive parts.

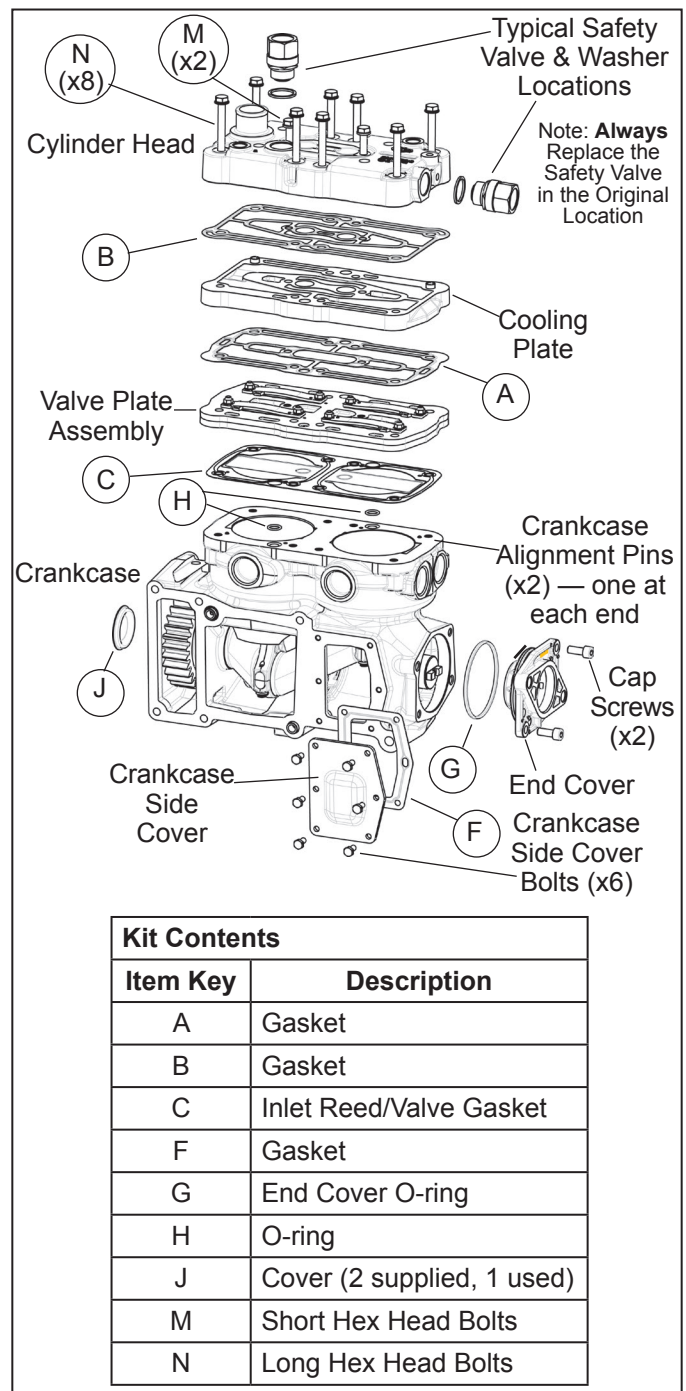

Figure 3 – Exploded View

## PREPARATION FOR DISASSEMBLY

Place a clean shop rag over the openings of the crankcase that expose the gear and crankshaft/connecting rod assembly (refer to Figures 1 and 2). No contamination is permitted in these areas.

Remove the balance of road dirt and grease from the exterior of the compressor with a cleaning solvent. If the rear end cover o-ring (G) is being replaced, mark the rear end cover and the two cap screws in relation to the crankcase. It is also recommended to mark the relationship of the cylinder head, cooling plate, valve plate assembly, and crankcase.

A convenient method to indicate the above relationships is to use a metal scribe to mark the parts with numbers or lines. Do not use marking methods, such as chalk, that can be wiped off, or obliterated, during rebuilding.

Prior to disassembly, make certain that the appropriate kits are available. Refer to Figure 3 during the entire disassembly and assembly procedure.

### CYLINDER HEAD, COOLING PLATE, & VALVE PLATE ASSEMBLY

1. Remove the two short hex head bolts (M) and eight long hex head bolts (N) from the cylinder head.
2. Gently tap the cylinder head, cooling plate, and valve plate assembly with a soft mallet to break the gasket seal between the valve plate assembly and the crankcase. Lift the cylinder head, with the cooling plate and valve plate assembly, off the crankcase.
3. Remove the metal inlet reed valve/gasket (C).
4. Remove the two crankcase o-rings (H) from the deck (top) of the crankcase. The o-rings are located in countersunk holes, one on each side of the cylinder bores.
5. Gently tap the cylinder head, cooling plate, and valve plate assembly with a soft mallet to break the gasket seals. Then separate the cylinder head from the cooling plate and valve plate assembly, and remove and discard the two head gaskets (A) and (B).

### CRANKCASE FRONT COVER

Carefully remove the cover (J) from the front of the crankcase, using a flat blade screwdriver or a scraper. Place the tool edge under the lip along the outside diameter of the cover. Gradually pry the cover from the cast surface until the entire cover can be removed.

### CRANKCASE SIDE COVER

1. Remove the six cap screws that retain the crankcase side cover to the crankcase.
2. Gently tap the crankcase side cover with a soft mallet to break the gasket seal between the crankcase side cover and the crankcase. Remove the crankcase side cover and the gasket (F).

### REAR END COVER

Note: There are two M8x1.25 cap screws used to retain the end cover to the crankcase. There are also two larger M10x1.5 cap screws (not shown) that are used to retain the auxiliary drive unit (e.g. hydraulic pump) via the end cover and torqued into the crankcase. If the auxiliary drive unit has already been removed, these two cap screws are no longer present on the end cover. Refer to Figure 4 to see the location of the cap screws in the end cover.

1. Remove the two end cover cap screws that secure the rear end cover to the crankcase.
2. Remove the rear end cover from the crankcase. Remove and discard the o-ring (G) from the end cover.

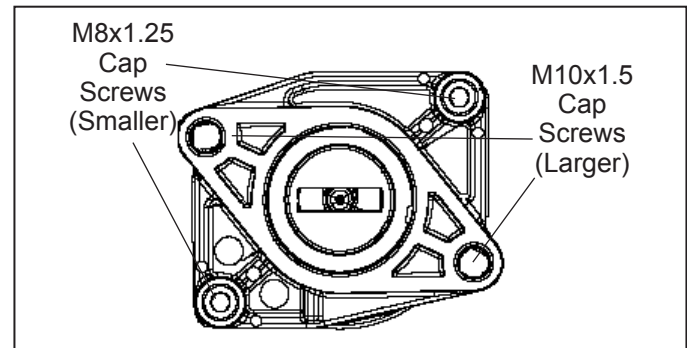

Figure 4 – Rear End Cover Attachment Bolts

## CLEANING OF PARTS

### GENERAL

All parts should be cleaned in a good commercial grade of solvent and dried prior to inspection.

### CRANKCASE

1. Carefully remove all sealant gasket material adhering to the machined mounting face of the crankcase. (See Figure 5). Make certain not to scratch or mar the mounting surface. Note: Keep the crankcase opening covered to prevent any of the sealant material from entering. Repeat this process on the engine mounting face as well. Follow the instructions contained in the vehicle maintenance manual in lieu of the instructions and procedures presented in this manual.
2. Carefully remove all gasket material adhering to the deck (top) of the crankcase. Remove any carbon deposits from the deck of the crankcase. Make certain not to scratch or mar the gasket surfaces.
3. Carefully remove all gasket material adhering to the machined surface on the side of the crankcase that retains the crankcase side cover. Make certain not to scratch or mar the gasket surfaces.

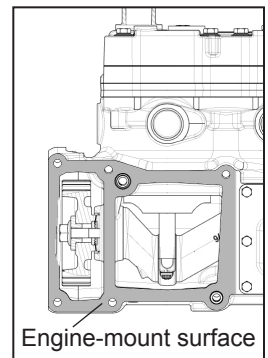

Figure 5 – Compressor-to-Engine Mounting Surface

### CYLINDER HEAD, COOLING PLATE, & VALVE PLATE ASSEMBLY

1. Carefully remove all gasket material adhering to the cylinder head, cooling plate, and valve plate assembly. Make certain not to scratch or mar the gasket surfaces. Pay

particular attention to the gasket surfaces of the cylinder head and cooling plate.

2. Remove carbon deposits from the discharge and inlet cavities of the cylinder head, cooling plate, and valve plate assembly. Make certain not to damage the parts while cleaning. The cavities must be open and clear.
3. Remove rust and scale from the cooling cavities and passages in the cylinder head, cooling plate, and valve plate assembly. Use shop air to clear debris from the passages.
4. Check the threads in all cylinder head ports for galling (e.g. abrasion, chafing). Minor thread chasing (damage) is permitted.

## INSPECTION OF PARTS

### CYLINDER HEAD, COOLING PLATE, & VALVE PLATE ASSEMBLY

1. Carefully inspect the head gasket surfaces on the cylinder head for deep gouges and nicks. Also, inspect the cylinder head for any cracks or port thread damage. If detected, the compressor must be replaced. If large amounts of carbon build-up are present in the discharge cavity, such that it restricts the air flow through the cylinder head, the compressor should be replaced.
2. Carefully inspect both sides of the head gasket surfaces on the cooling plate for deep gouges and nicks. Also, inspect the cooling plate for any cracks or other damage. If damage is found, the compressor must be replaced.
3. Carefully inspect the valve plate assembly gasket surfaces (both sides) for deep gouges and nicks. Pay particular attention to the gasket surface. An inlet reed valve/gasket (C) is used between the valve plate assembly and the crankcase. These gasket surfaces must be smooth and free of all but the most minor scratches. If excessive marring or gouging is found, the compressor must be replaced. If large amounts of carbon build-up are present on the two main surfaces, in the two discharge valve holes, or between the discharge valve and the discharge seat, the compressor should be replaced.

### REAR END COVER

Visually inspect for cracks and external damage. Check the crankshaft rear bearing diameter in the rear end cover for excessive wear, flat spots, or galling. Check the pilot and threaded holes of the hydraulic pump attachment for damage. Minor thread chasing is permitted, but do not re-cut the threads. If any of these conditions are found, replace the compressor.

## CRANKCASE

Check the cylinder head gasket surface on the deck (top) of the crankcase for nicks, gouges, and marring. A metal gasket is used to seal the cylinder head to the crankcase, and in order for the gasket to seal properly, this surface must be smooth and free of all but the most minor scratching. If excessive marring or gouging is detected, the compressor must be replaced.

Check the condition of the two countersunk holes on the deck of the crankcase that retain the o-rings (H) and prevent coolant leakage between the valve plate assembly and the crankcase. The surface in contact with the o-ring should be smooth and free of any scratches and gouges that could cause leakage around the o-rings.

## ASSEMBLY

### GENERAL

Note: All torques specified in this manual are assembly torques and typically can be expected to fall off after assembly is accomplished. Do not re-torque after the initial assembly torques fall, unless instructed otherwise. A compiled listing of torque specifications is presented on page 7.

### CRANKCASE FRONT COVER

Position the new cover (J) over the hole in the front of the crankcase. Using a rubber mallet, drive the cover into the hole in the front of the crankcase until the outside diameter of the cover is flush with cast surface.

### CRANKCASE SIDE COVER

Position the gasket (F) on the crankcase side cover and install the crankcase side cover on the side of the crankcase using the six cap screws. "Snug" all six cap screws then torque between 101 and 112 in-lbs (11.4-12.6 Nm). When torquing the bolts, it is best to start with the two mid bolts then use a crossing pattern with the four remaining bolts.

### REAR END COVER

1. Install the o-ring (G) on the rear end cover.
2. Orient the rear end cover to the crankcase using the reference marks made during disassembly. Carefully install the rear end cover in the crankcase making certain not to damage the crankshaft bearing surface.
3. Install the two end cover cap screws. *Refer to Figure 4 to ensure that the two cap screws are installed in the proper crankcase bolt holes.* "Snug" the screws then tighten between 195 and 212 in-lbs (22-24 Nm).
4. *Refer to the vehicle maintenance manual to re-install the hydraulic pump to compressor end cover.*

## CYLINDER HEAD, COOLING PLATE, & VALVE PLATE ASSEMBLY

1. Install the two crankcase o-rings (H) into the countersunk holes on the deck of the crankcase.
2. Note the position of the two protruding crankcase alignment pins on the deck (top) of the crankcase. Install the metal inlet reed valve/gasket (C) over the alignment pins on the crankcase; being careful not to disturb the crankcase o-ring (H).
3. Position the valve plate assembly on the crankcase so that the alignment pins in the crankcase fit into the corresponding holes in the valve plate assembly.
4. Position the first embossed metal head gasket (B) over the alignment bushings protruding from the top of the cooling plate. Position the second embossed metal head gasket (A) over the alignment bushings on the opposite side of the cooling plate. When properly positioned, the outline of the two embossed gaskets match the outline of the cooling plate and the machined sealing surfaces on the cooling plate will be covered by the embossed metal gasket material. **Important: The two gaskets are different and must be installed on the proper side of the cooling plate for the compressor to function properly. See Figure 6 for proper head gasket identification positions.**
5. Install the cooling plate with the head gaskets onto the valve plate assembly by lining up the alignment bushings on the cooling plate over the oversized countersunk holes of the valve plate assembly. Again, when properly installed, the outline of the cooling plate matches the outline of the valve plate assembly.

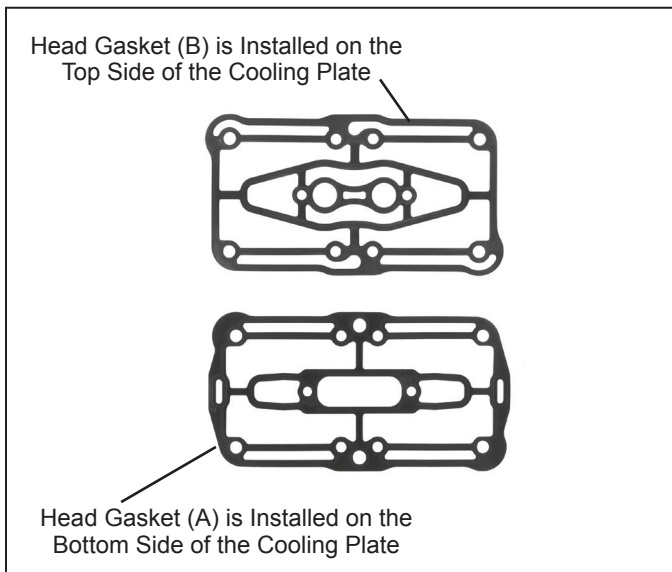
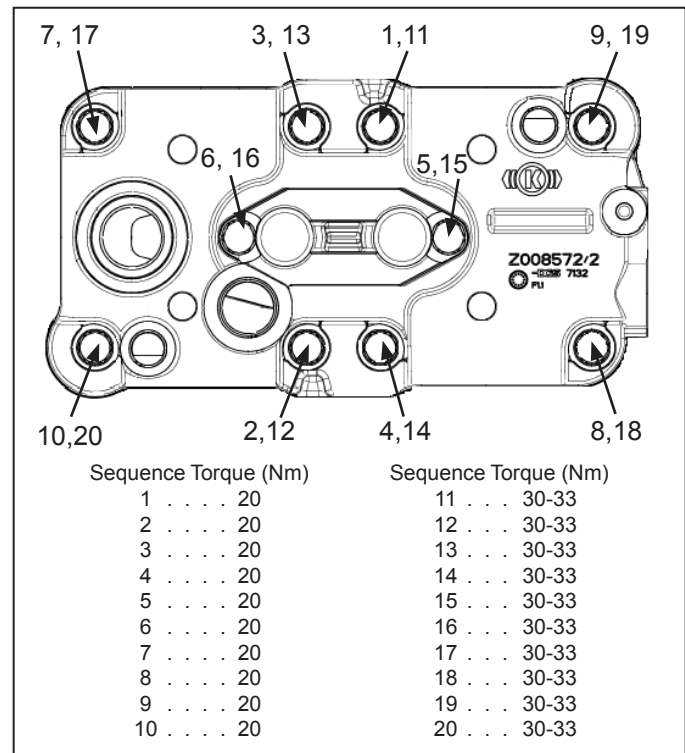

**Figure 6 – Bendix® 720cc Compressor Head Gaskets Position**

6. Position and install the cylinder head over the alignment bushings protruding from the cooling plate. When properly installed, the outline of the cylinder head assembly will match the outline of the cooling plate and the valve plate assembly.

**Note:** To assist with correct installation, the alignment bushings in the cooling plate only fit into two of the four corner head bolt holes on the valve plate assembly and the cylinder head.

7. Install the eight long head cap screws (N) into the cylinder head. **Note: A light film of oil should be applied to the threads of these screw bolts prior to installing. Oil should not be applied to any of the other bolts.**
8. Install the two short head cap screws (M) into the cylinder head. Important: The two short head cap screws (M) must be installed in the hole positions designated as sequence “6,16” and “5,15” in Figure 7.
9. “Snug” all the head cap screws, then tighten using the torque sequence defined in Figure 7. The final torque will be between 265 and 292 in-lbs (30-33 Nm).



**Figure 7 – Bendix® 720cc Compressor Cylinder Head Bolt Torque Sequence**

## TORQUE SPECIFICATIONS

Bolt, Nut, or Screw .....	Assembly Torques
Cylinder Head (M8x1.25-6g) . . . . .	265-292 In-lbs. (30-33 Nm) Max
End Cover (M10x1.25-6g) . . . . .	195-213 In-lbs. (22-24 Nm) Max
Crankcase Side Cover Bolts (M6x1) . . . . .	101-112 In-lbs. (11.4-12.6 Nm) Max
Discharge Port Fittings (M26x1.5) . . . . .	66 ft-lbs. (90 Nm) Max
Water Port Fittings (M16x1.5) . . . . .	33 ft-lbs. (45 Nm) Max
Safety Valve Port (M26x1.5) . . . . .	59-66 ft-lbs. (80-90 Nm) Max

## INSTALLING THE COMPRESSOR

1. Apply a liquid gasket sealant to the compressor / engine mounting interface (*Refer to Figure 5 for compressor mounting face*). Follow the Engine or Vehicle Manufacturer's guidelines for the proper liquid gasket sealant material and application procedure.
2. Align the locating pins on the compressor onto the mating holes on the engine mounting surface. Secure the compressor to the engine using the six mounting bolts. **Note:** There are two short bolts and four long bolts. Be sure the use the proper length bolt for the crankcase bolt holes. Run each of the bolts down finger tight, making sure not to smear the liquid gasket material on the sealing surface. Once the bolts are all finger tight, tighten the mounting bolts per Engine Manufacturer's recommended torquing sequence and torque requirements.
3. Install any supporting brackets on the compressor in the same position(s) noted and marked during removal.
4. Inspect all air and coolant lines and fittings before reconnecting them to the compressor. Make certain o-ring seals are in good or new condition, the threads are clean and the fittings are free of corrosion. Replace as necessary.
5. Install the discharge and coolant fittings, if applicable, in the same position on the compressor noted and marked during disassembly. See the Torque Specifications for various fitting sizes and types of thread on this page. Tighten all hose clamps.
6. Before returning the vehicle to service, perform the *Operation and Leakage Tests* that follow. Pay particular attention to all lines and hoses disconnected during the maintenance and check for air, oil, and coolant leaks at compressor connections and the compressor engine interface. Also check for noisy operation.

## OPERATION & LEAKAGE TESTS

Note: The Bendix® 720cc DLU-style compressor does not contain components to unload the compressor. Therefore, the compressor pumps continuously. In most systems that utilize an air dryer, the governor and DLU-style air dryer are used to unload the system (i.e. air is not being delivered to the brake system reservoirs). When system unloading occurs, air from the compressor will typically flow out the exhaust port of the air dryer.

1. Start the engine and note that air system steadily builds pressure.
2. With system air pressure increasing, check for cylinder head gasket air leakage. Apply a soap solution around the cylinder head. Check the gaskets between the cylinder head, cooling plate, and valve plate assembly for air leakage. No leakage is permitted. If leakage is detected, try draining all air pressure and then re-torquing the head bolts. Replace the compressor if replacing the head gasket has not resolved the leakage problem.
3. Allow air system pressure to build and note that the unloading system unloads properly at the specified governor cut-out pressure. Repeat this test three times noting that the compressor unloads at approximately the same pressure each time. If the compressor fails to unload by at least 150 psi system pressure, check all air lines to and from the governor. Make certain each line is clear (unobstructed) and not kinked, or leaking. Repair or replace the governor as needed.
4. More complete compressor performance tests are provided in the *Bendix Service Data Sheet*.

All Service Data sheets are available for free download from [bendix.com](http://bendix.com). You may also order paper copies from the Literature Center at [bendix.com](http://bendix.com) or by calling 1-800-AIR-BRAKE (1-800-247-2725), option 5.



**Trucking moves fast. Move faster.**  
**Knowledge Dock™**  
• BLOGS • PODCASTS • VIDEOS • 24/7/365  
[ [knowledge-dock.com](http://knowledge-dock.com) ]



**Log-on and Learn from the Best**  
On-line training that's available when you are – 24/7/365.  
Visit [brake-school.com](http://brake-school.com).