

## Bendix® EC-16™ AntiLock - Traction Controller

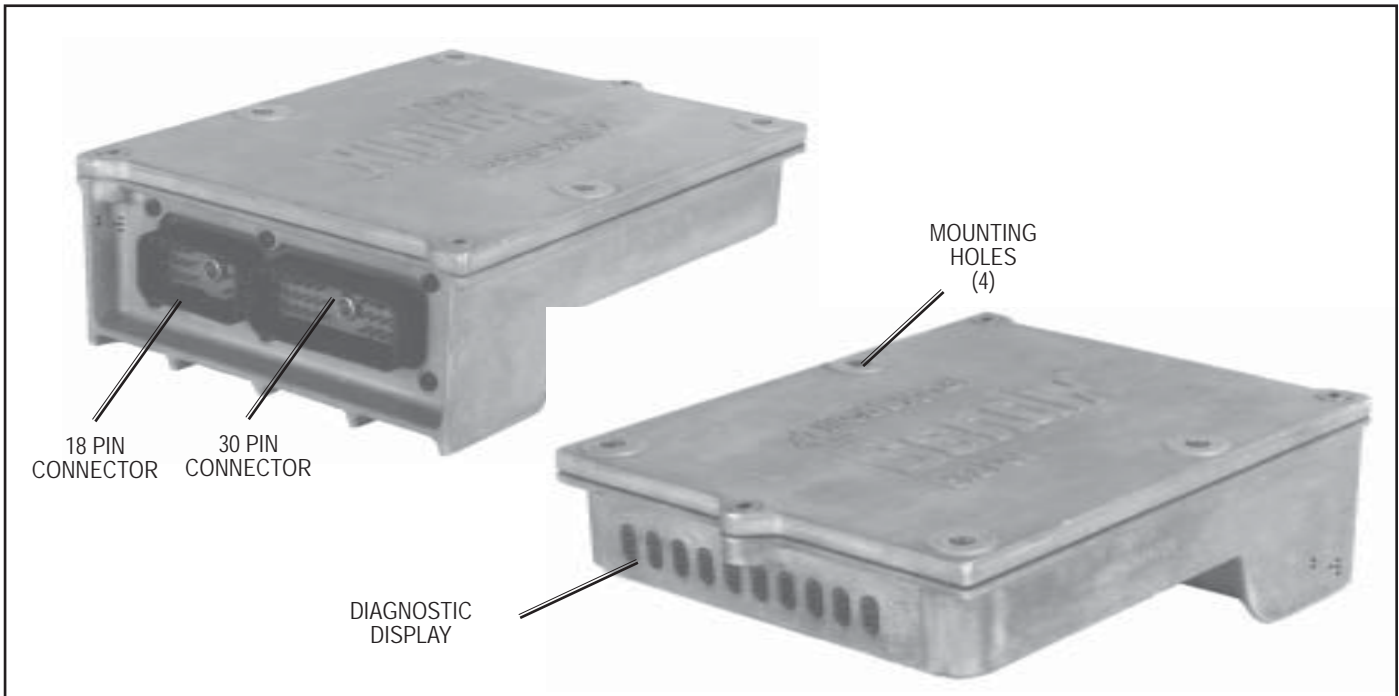

FIGURE 1 - EC-16™ CONTROLLER

### DESCRIPTION

#### GENERAL

The EC-16™ is an electronic antilock controller. It is the base component in a family of full vehicle wheel control antilock systems for buses, trucks and truck tractors. In addition to the antilock function, the EC-16™ controller can be assembled and programmed to provide an optional traction control feature. Figure 1 shows the basic EC-16™ controller configuration.

Designed to minimize the potential of brake lock up on all wheels during aggressive braking, the EC-16™ controller based antilock system provides the vehicle with a high degree of stability and steerability during braking. In most cases, vehicle stopping distance is also reduced. The antilock portion of the EC-16™ controller based system minimizes wheel skid during hard or aggressive braking. By controlling wheel skid at all wheels on the vehicle, optimum steering control and stopping distance is obtained.

Traction control, an optional feature in the full vehicle wheel control antilock system, helps improve vehicle traction during acceleration in adverse road conditions. Integrated

with antilock logic, traction control monitors wheel speed information from the sensors during acceleration, as well as braking. The system helps maintain vehicle stability on hazardous road surfaces and improves driveability and safety.

There are two versions of the EC-16™ controller. The older version, was factory pre-programmed with vehicle particulars, such as the number of speed sensors, if the traction control feature was enabled and the type of traction control (torque limiting, differential braking or both). A part number was assigned to the EC-16™ controller which was specific for the programmed features contained in the unit. The newer version contains a self configuring or learning feature that allows the EC-16™ controller to be configured by the user when installed on the vehicle. Because of this feature, all of the new version EC-16™ controllers contain all the features and options available and will activate the specific features required for the vehicle it is installed on. The new version EC-16™ controller can be installed on vehicles with only antilock or vehicles using the traction control feature. The procedure for activating the self

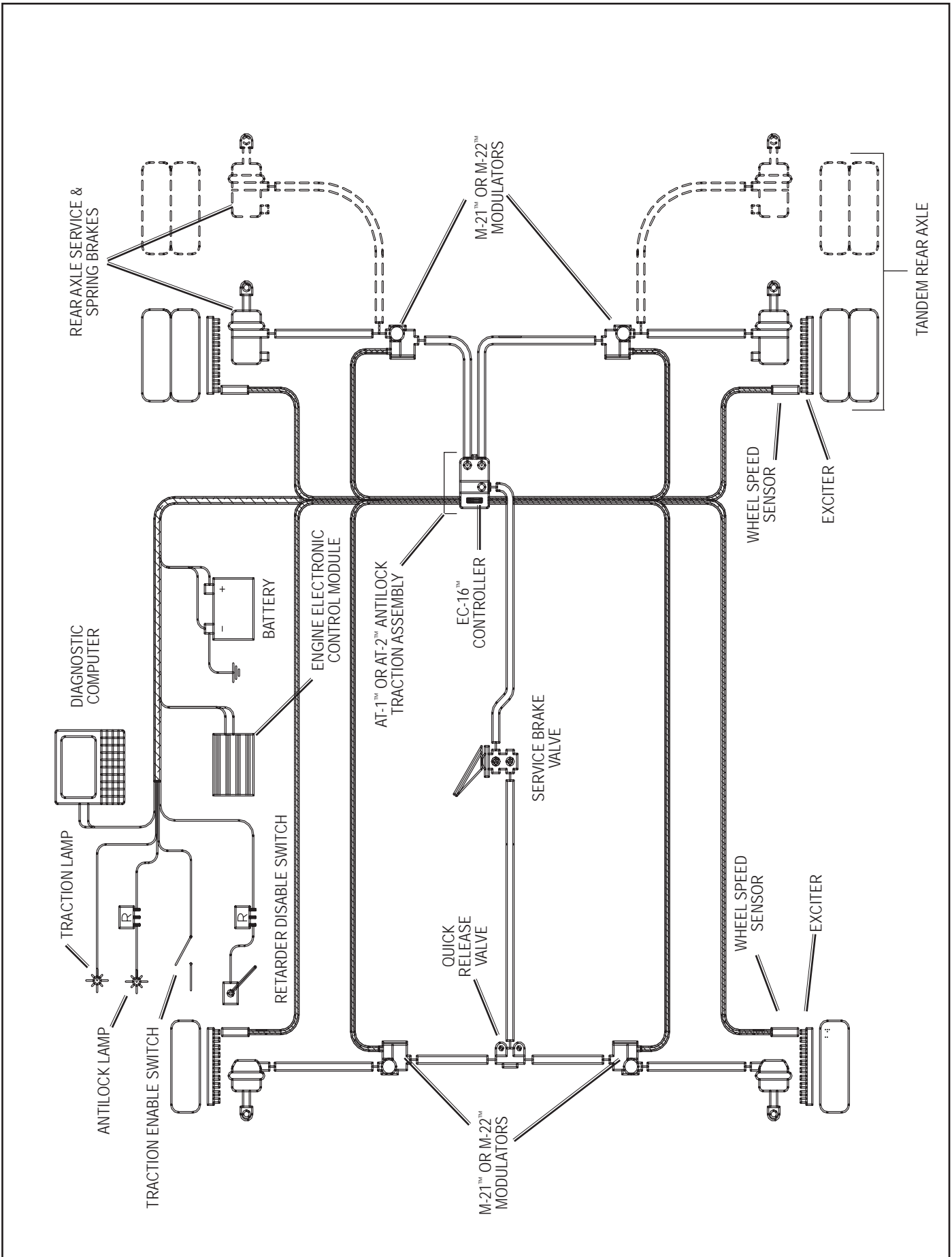

FIGURE 2 - EC-16™ CONTROLLER SYSTEM SCHEMATIC

configuring feature and identifying old and new version EC-16™ controllers is contained in the section entitled “Configuring The EC-16™ Controller”.

In order to provide full vehicle wheel control antilock, the EC-16™ controller is used in combination with the following components:

- Four wheel speed sensors
- Four air pressure modulator valves
- One dash mounted antilock condition lamp
- One service brake relay valve

When programmed to provide traction control in addition to antilock, the following components are added:

- One traction solenoid (incorporated into the relay valve)
- Two additional wheel speed sensors (optional for tandem drive vehicles with differential braking feature)
- One dash mounted traction condition lamp
- Serial connection to engine control module (for vehicles programmed for torque limiting feature)
- Traction disable wiring and switch

## PHYSICAL

The EC-16™ controller electronics are contained in a die cast aluminum housing and are environmentally protected by a self healing silicone compound. The metal housing and the design of the digital electronics are intended to provide a high degree of protection from radio and electromagnetic interference.

The patented light emitting diode (LED) display and a magnetically actuated reset switch is incorporated in the housing for troubleshooting and diagnostic purposes.

Two electrical connectors located in the controller housing opposite the diagnostic display, connect the EC-16™ controller to antilock and traction system components: one 30 pin and one 18 pin Packard Electric 150 series “Metri pack” connector. In addition to these two housing mounted connectors, the EC-16™ controller also uses a 2 pin Deutsch connector when programmed with the optional traction control feature. The 2 pin connector is linked to a traction solenoid, which is located in the upper portion of the antilock traction relay valve assembly. (See Figure 3.)

## MOUNTING

The EC-16™ controller is available in two different mounting styles. One model, shown in Figure 1, is a stand-alone. It is intended for bracket mounting to a frame member and is not attached to an antilock relay valve.

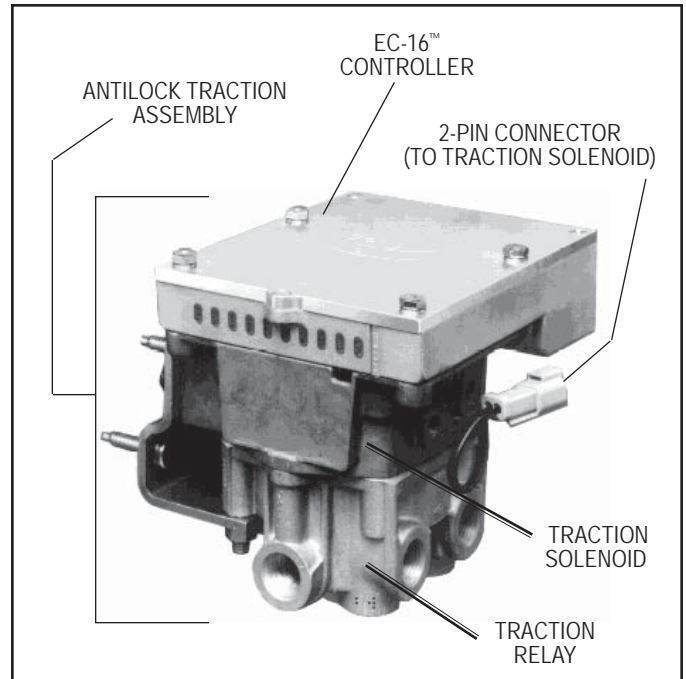

FIGURE 3 - EC-16™ CONTROLLER W/ANTILOCK TRACTION RELAY VALVE

The other EC-16™ controller is designed to be mounted on one of four different valves. All of the valves provide the relay function and replace the standard service relay on antilock equipped vehicles. In some instances the valves also provide specialized functions. When the EC-16™ controller is mounted on any of these valves, the result is a final assembly with its own model designation. Refer to the chart and figure 3.

AntiLock Valve	Added Function Provided	Vehicle Application	Designation (Valve + EC-16)
AR 1	None	All	CR 17 Controller Relay
AR 2	Bobtail Brake Proportioning	Tractors Only	CR 18 Controller Relay
ATR-1	Traction	All	AT 1 AntiLock Traction
ATR 2	Traction & Bobtail Brake Proportioning	Tractors Only	AT 2 AntiLock Traction

## EC-16™ CONTROLLER INFORMATIONAL INPUTS AND COMMAND OUTPUTS

### GENERAL

The EC-16™ controller receives information from several components in system and, based on these inputs, issues commands or delivers information. Some portions of the EC-16™ controller both receive and deliver commands and information. (See Figure 4.)

### INPUTS

- **Wheel speed** information is provided to the EC-16™ controller via a wiring harness from individual wheel speed sensors at or in the vehicle wheels. Working with an exciter or tone ring, wheel speed sensors provide information to

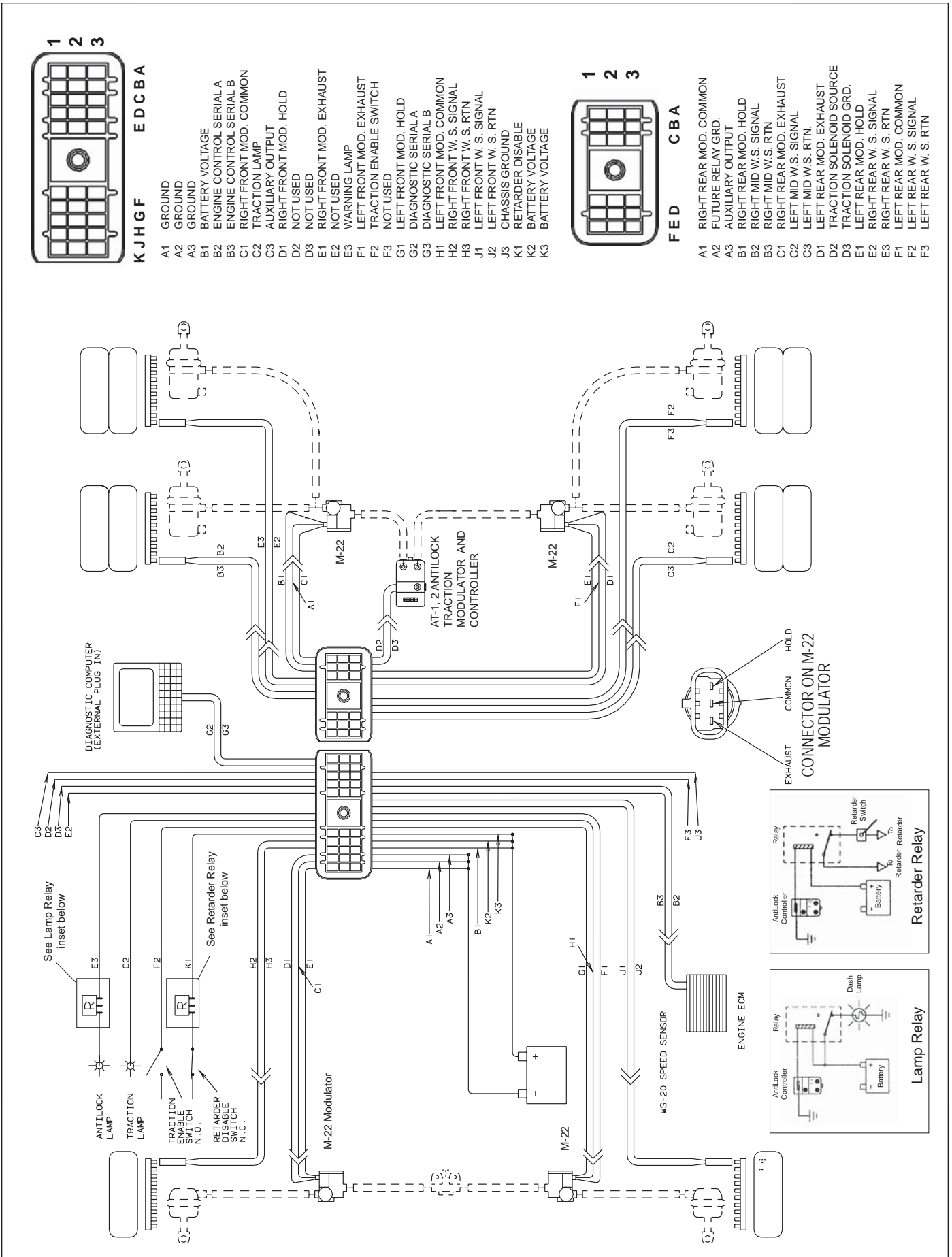

FIGURE 4 - EC-16™ CONTROLLER SYSTEM WIRING SCHEMATIC

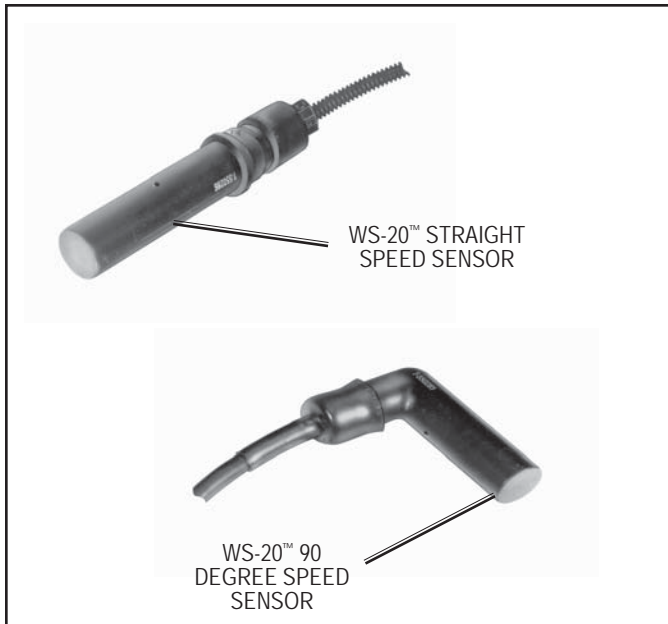

FIGURE 5 - WS-20™ SPEED SENSORS

the EC-16™ controller in the form of an AC signal which varies in voltage and frequency as the speed of the wheel increases or decreases. The EC-16™ controller is designed to receive wheel speed information, from various wheel speed sensor models, at the rate of 100 pulses per wheel revolution. The EC-16™ controller is able to simultaneously receive, and individually interpret, speed signals from six wheel speed sensors. Vehicle drive configuration and whether the traction control feature is in use determines the number of speed sensors that must be used. A vehicle with a single rear axle drive (4 x 2, 4 x 4 or 6 x 2) requires 4 speed sensors for both antilock and traction operation. A vehicle with two rear drive axles (6 x 4) requires 4 speed sensors for antilock only operation, but have the option to use 6 speed sensors for enhanced performance of both antilock and traction operation.

- **Vehicle power** is supplied to the EC-16™ controller from the ignition switch through a fuse or circuit breaker. (30 amp.) The electrical ground for the EC-16™ controller is the vehicle chassis.

- A connection for a **traction enable switch** is provided, but not always used. The switch allows traction to be turned on or off manually.

## OUTPUTS

- **Modulators**, like the Bendix® M-21™ or M-22™ modulator, are the means by which the EC-16™ controller modifies driver applied air pressure to the service brakes. The modulator is an electrically controlled air valve located near the service actuator(s) it controls. It is the last valve that air passes through on its way to the brake actuator. A wiring harness connects the modulator to the EC-16™ antilock controller. Solenoid valves contained in the modulator provide the electrical interface between the

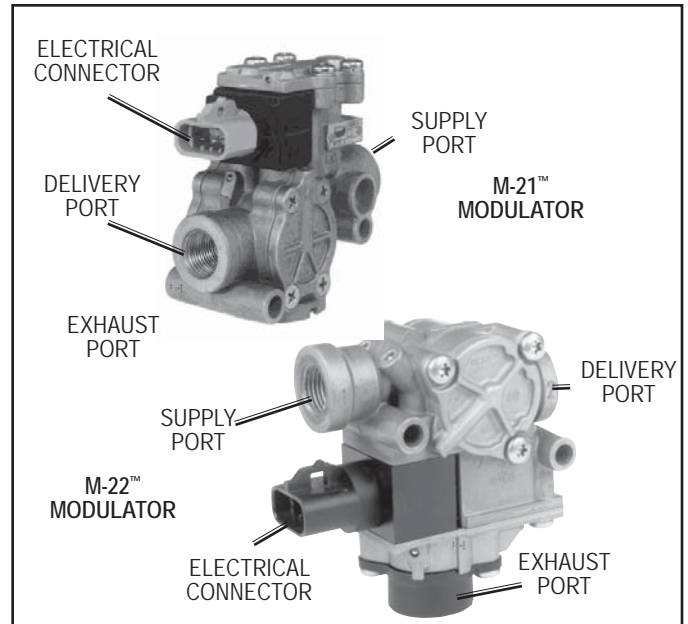

FIGURE 6 - MODULATORS

EC-16™ controller electronics and the air brake system. The EC-16™ controller is able to simultaneously and independently control four individual modulator assemblies.

- An **antilock dash light** and its electrical relay are connected to, and controlled by, the EC-16™ controller and serve as a means of advising the driver of the condition of the antilock system.

- A connection to the engine or transmission **retarder** and its relay is provided on the EC-16™ controller, which allows the EC-16™ controller to temporarily disable the retarder during certain modes of operation. While the EC-16™ controller is capable of this function, and connections are provided, it is not always used. Use of the retarder disable function is not essential but highly recommended for vehicles equipped with a retarder.

**Note:** The EC-16™ controller can also disable the retarder using the same J1922 protocol it uses to control the traction control, engine torque limiting feature. For this redundant retarder disable to function, the EC-16™ controller must be connected to the engine control module (as would be the case if the EC-16™ controller is programmed for the traction control, torque limiting feature).

- The **data link** enables the EC-16™ controller to “report” its operating condition to a specialized, external computer in response to certain commands it receives. The EC-16™ controller diagnostic data link hardware conforms to S.A.E. standard J1708. The protocol, or coded language used, conforms to S.A.E. standard J1587. There are two connections to the EC-16™ controller devoted to the data link. While connections are provided for this function, it is not always used. The data link is not essential for the EC-16™ controller to be functional.



If the EC-16™ controller is programmed for traction control, it contains the following outputs:

- A connection to the **engine's electronic control module** allows the EC-16™ controller to reduce engine torque under certain circumstances.
- A **traction dash light** is connected to and controlled by the EC-16™ controller and serves as a means of advising the driver of the condition of the traction control system.
- A connection to the **traction solenoid** (located in the upper portion of the antilock traction relay valve—see Figure 3) is provided via a 2 pin Deutsch connector.

## OPERATION - ANTILOCK

### PHILOSOPHY

The Bendix® EC-16™ controller antilock system uses individual sensors, modulators and an electronic controller to control the four vehicle wheel ends. By monitoring the deceleration rate during braking, and subsequently adjusting the brake application pressure at each wheel, the EC-16™ controller is able to improve braking between the vehicle tire and the road surface it is on, while maintaining vehicle stability.

The rear axle brakes are controlled independently; therefore brake application pressure at an individual wheel is adjusted solely on the basis of its behavior on the road surface on which it is traveling.

While each steering axle brake is under the control of an individual modulator, the EC-16™ controller does not treat these brakes totally independently. The EC-16™ controller uses a modified individual control philosophy for the steering axle brakes. This is done in order to minimize “steering wheel pull” in the event each wheel is traveling on a different road surface (for example, ice close to the curb and a dry crown). Essentially the EC-16™ controller controls the braking force differences between the two brakes.

The wheel on dry pavement is initially given less braking force and is brought up to optimum during the stop, while the wheel on ice attempts to maintain optimum braking during the entire stop.

In the case of vehicles equipped with tandem rear axles (6x2, 6x4), the wheel speed sensors are installed at the wheels on the axle that is most likely to lock first. A single modulator controls both curb side brakes on the tandem, and another modulator controls both brakes on the driver's side of the tandem. With this arrangement of speed sensors and modulators, both brakes on one side of the tandem are treated as one since they will most likely be on the same type of road surface.

## NON ANTILOCK BRAKE APPLICATION

During normal braking, air pressure from the brake valve enters the control port of the service relay valve. The service relay delivers air to, and through, the antilock modulator located near the braked wheel, and into the brake actuator. The service brakes are thus applied. If the wheel sensors do not detect an impending wheel lock up, the EC-16™ controller does not initiate any corrective action and the vehicle comes to a stop in a normal fashion.

## ANTILOCK BRAKE APPLICATION

If a service brake application is made and the wheel speed sensors detect an impending wheel lockup, the EC-16™ controller will immediately begin modification of the brake application using the antilock modulator(s) at the affected wheel(s). Solenoid valves contained in the modulator are energized and de energized by the EC-16™ controller in order to modify the brake application. When a solenoid coil is energized, its shuttle moves. Depending upon the function of the specific solenoid, it either opens or closes, thereby causing the exhaust or re application of air pressure to the brake actuator. The solenoids in each modulator are controlled independently by the EC-16™ controller. By opening and closing the solenoid valves in the appropriate modulator, the EC-16™ controller is actually simulating what drivers do when they “pump the brakes”. It must be remembered however that unlike the driver, the EC-16™ controller is able to “pump” each brake on the vehicle independently and with far greater speed and accuracy.

## OPERATION - TRACTION CONTROL

### PHILOSOPHY

Traction control is a natural extension of antilock. Just as antilock helps vehicle control and stability during braking, traction control helps during vehicle acceleration. The wheel speed sensors not only detect rapid decreases in wheel speed for antilock but also detect unreasonably high increases for traction control. With traction control, a spinning wheel is instantly detected and compared with the other wheels on the vehicle, both front and rear. Two different methods are used to control wheel spin; torque limiting and differential braking. Depending upon vehicle type, speed and road (surface) condition, each method provides a unique and desirable type of wheel spin control. Ideally both methods are used to control vehicle traction. While all new version EC-16™ controllers are capable of providing wheel control antilock and traction control (utilizing both methods of control), not all systems will be configured for both methods. Depending upon the vehicle, either or both traction control methods will be activated during the self configuration procedure.

Torque Limiting - In order for the torque limiting control feature to be used, the vehicle must be equipped with an electronically controlled engine throttle. The torque limiting feature allows the EC-16™ controller to reduce engine torque to a suitable level for the available traction. Torque limiting helps to minimize the amount (or speed) of wheel spin. It is especially useful in helping to minimizing a power jackknife and when all drive wheels are on an equally slippery surface.

Differential Braking - In order for the differential braking control feature to be used, the vehicle must be equipped with an antilock traction relay valve such as the Bendix® ATR-1™ or ATR-2™ relay valve. The ATR-1™ and ATR-2™ relay valve contain a solenoid assembly which provides this feature. The differential braking feature allows the EC-16™ controller to gently pump the brake on the spinning wheel. Since the vehicle's differential tends to drive the wheel that presents the least resistance (the wheel on the slipperiest surface), a slight brake application to this wheel only, forces the differential to drive the stationary or slowly spinning wheel. While a vehicle must be equipped with an electronic throttle to utilize the torque limiting feature of traction control, differential braking can be used on all vehicles. Differential braking can be activated only when vehicle speed is under 25 MPH and one drive wheel is spinning faster than the other(s).

## **TRACTION CONTROL AT VEHICLE SPEEDS OF 0 TO 25 MPH**

When wheel spin is detected and the vehicle is stopped, or moving at any speed up to 25 mph, the EC-16™ controller simultaneously executes the following operations:

It instantly blinks the traction dash lamp to advise the driver that a wheel spin is occurring.

If the torque limiting feature is active, the EC-16™ controller uses its link to the engine control module and sends a signal to reduce engine torque to a level suitable for the available traction.

If the differential braking feature is configured into the system, the EC-16™ controller energizes the solenoid in the ATR valve which then applies air to each of the rear axle modulators. Because the modulators are controlled by the EC-16™ controller, the solenoid valves in the appropriate modulator are opened and closed to gently pump the brake on the spinning wheel only. This gentle brake application forces the differential to drive the stationary or slowly spinning wheel.

Once wheel spin is eliminated, the dash lamp goes out and the traction system disengages control.

## **TRACTION CONTROL AT VEHICLE SPEEDS ABOVE 25 MPH**

If wheel spin occurs at any speed above 25 mph, the EC-16™ controller will instantly blink the traction dash lamp to advise the driver that a wheel spin is occurring.

If the torque limiting feature is programmed in, the EC-16™ controller uses its link to the engine control module and sends a signal to reduce engine torque to a level suitable for the available traction.

THE EC-16™ CONTROLLER WILL NOT SIGNAL THE ATR VALVE TO APPLY THE BRAKES, EVEN SLIGHTLY, AT ANY SPEED ABOVE 25 MPH.

## **ANTILOCK AND TRACTION SYSTEM OPERATION DURING COMPONENT FAILURE**

The Bendix® EC-16™ controller handles equipment failure using a conservative fail safe philosophy. Any single electrical failure of a component devoted to antilock or traction control results in simultaneous illumination of the appropriate condition lamp on the dash, a disabling of part or all of the antilock or traction system, and reversion to standard braking on wheels no longer under EC-16™ controller control.

Depending upon the type of failure and its position of occurrence, the EC-16™ controller disables all or only a portion of the antilock and traction system. A power or controller failure, however, will result in complete disabling of both systems and reversion to standard braking on all wheels.

### **SINGLE FAILURE**

The following list and chart describe how the antilock and traction systems respond to a specific component failure. (Note: right and left; front, mid and rear are determined from the driver's seat. Left front is therefore the corner closest to the driver.)

For example, if the right mid sensor ("RM Sensor" on the chart) fails, front and rear antilock will still be operative. Traction will be disabled, and, as always, the system has standard air braking.

Front modulator - If a front modulator fails, antilock on that wheel is disabled. Antilock and traction on all other wheels remains active.

Rear modulator - A rear modulator failure disables the traction system. Antilock on that wheel will also be disabled, but antilock on all other wheels remains active.

Front sensor - The wheel is still modulated using input from the opposite sensor. The traction system is disabled.

Mid or rear sensor - Antilock on that wheel is disabled, but antilock on all other wheels remains active. Traction control is disabled.

Controller - Antilock and traction are disabled. The system reverts to standard air braking.

Traction solenoid - Traction control is disabled. Antilock remains active.

Engine Control Module\* - If the engine control module (ECM) or the wiring from the EC-16™ controller to the ECM fails, traction control is disabled. Antilock remains active.

Voltage\* - If system voltage is out of range, antilock and traction are disabled. The system reverts to standard air braking.

**\*Note:** A voltage problem and an intermittent ECM wiring problem can “correct” themselves. For example, a power surge can take the system out of voltage range for a moment, which will flash the voltage LED and an intermittent wiring problem between the EC-16™ controller and the ECM can cause the traction LED to go on. During the time that the problem is occurring, the dash lamp will also be on. When the problem corrects itself, the system is restored. The dash lamp and the appropriate LED go out.

For all other problems, the system will not be restored in the problem area until the error is corrected and the EC-16™ controller is cleared with the reset switch. It should be remembered that the driver will be advised of the degraded operation via the dash lamps and that standard air braking will still be available on those brakes where the EC-16™ controller has disabled the system.

## MULTIPLE FAILURES

In the event that multiple failures occur, the dash lamp will react as it normally would during a single failure, and the LEDs will show one failure at a time. When the first problem is fixed and the system is reset, the next problem area will appear at the LEDs. This way, the driver or mechanic does not lose track of problem areas, and the system is not restored until each and every error is corrected and the EC-16™ controller is reset.

SYSTEM STILL OPERATING (YES/NO)							
	ABS Front		ABS Rear		Traction	Std. Braking	
	Left	Right	Left	Right			
RF Sensor	YES	YES	YES	YES	NO	YES	
LF Sensor	YES	YES	YES	YES	NO	YES	
RM Sensor	YES	YES	YES	YES	NO	YES	
LM Sensor	YES	YES	YES	YES	NO	YES	
RR Sensor	YES	YES	YES	NO	NO	YES	
LR Sensor	YES	YES	NO	YES	NO	YES	
RF Modulator	YES	NO	YES	YES	YES	YES	
LF Modulator	NO	YES	YES	YES	YES	YES	
RR Modulator	YES	YES	YES	NO	NO	YES	
LR Modulator	YES	YES	NO	YES	NO	YES	
Controller	NO	NO	NO	NO	NO	YES	
Solenoid	YES	YES	YES	YES	NO	YES	
Engine Control Module*	YES	YES	YES	YES	NO	YES	
Voltage*	NO	NO	NO	NO	NO	YES	

\*When ECM wiring or voltage “corrects” itself, system is restored.

## ANTILOCK AND TRACTION WIRING

### GENERAL NOTES

The wires that carry information and power into and out of the EC-16™ controller are generally grouped and terminate at a connector. The wire groups or wire harnesses along with the connectors are most often specified and/or supplied by the vehicle manufacturer. The connectors used on the EC-16™ controller are illustrated in Figure 4. The wiring harnesses and connectors are weather resistant and the wires that enter the connector are sealed to the connector. The wire gauge used in the wire harnesses is specific to the task performed.

When diagnosing wiring in the antilock system the following general rules apply and should be followed where applicable:

1. It is generally advisable to replace a wire harness rather than repair individual wires in the harness. If a splice repair must be made, it is important that the splice be properly soldered with a rosin flux (not acid based) and made water proof.
2. Do not pierce wire insulation when checking for continuity. Check for power, ground or continuity by disconnecting the connector and testing the individual pins or sockets in the connector.
3. Always check the vehicle handbook for wire and connector identification. Individual wire identification will differ depending upon the type of connectors in use, the vehicle manufacturer, and the system features in use.
4. While the retarder disable, serial link, and traction on/off connections (4 total) are present on all EC-16™ controllers they are not always used.



## PREVENTIVE MAINTENANCE

Every 3 months; 25,000 miles; or 900 operating hours;

1. Check all wiring and connectors to ensure they are secure and free from visible damage.
2. Although the EC-16™ controller incorporates self check diagnostics, the LED display should be inspected to ensure that it is functional. With the vehicle ignition on, a magnet (800 gauss; capable of picking up 3 ounces) held to the LED reset switch should cause all of the LEDs to illuminate. If one or more of the LEDs DO NOT ILLUMINATE and the dash condition lamps indicate the system is functioning properly, the nonilluminated LED(s) should be noted for future reference. Although the diagnostic capabilities will be limited, the system will continue to function as designed.
3. Road test the vehicle by making an antilock stop from a vehicle speed of 20 miles per hour. When an antilock stop is made, the modulator solenoids pulsate and an audible burst of air can be heard from outside of the cab. The wheels should not enter a prolonged “lock” condition. Also, make a traction acceleration by accelerating on a road surface with reduced traction. As with antilock, audible bursts of air can be heard when the traction system is functioning.

### **WARNING! PLEASE READ AND FOLLOW THESE INSTRUCTIONS TO AVOID PERSONAL INJURY OR DEATH:**

When working on or around a vehicle, the following general precautions should be observed at all times.

1. Park the vehicle on a level surface, apply the parking brakes, and always block the wheels. Always wear safety glasses.
2. Stop the engine and remove ignition key when working under or around the vehicle. When working in the engine compartment, the engine should be shut off and the ignition key should be removed. Where circumstances require that the engine be in operation, EXTREME CAUTION should be used to prevent personal injury resulting from contact with moving, rotating, leaking, heated or electrically charged components.
3. Do not attempt to install, remove, disassemble or assemble a component until you have read and thoroughly understand the recommended procedures. Use only the proper tools and observe all precautions pertaining to use of those tools.
4. If the work is being performed on the vehicle's air brake system, or any auxiliary pressurized air systems, make certain to drain the air pressure from all reservoirs before beginning ANY work on the vehicle. If the vehicle is equipped with an AD-IS® air dryer system or a dryer reservoir module, be sure to drain the purge reservoir.

5. Following the vehicle manufacturer's recommended procedures, deactivate the electrical system in a manner that safely removes all electrical power from the vehicle.
6. Never exceed manufacturer's recommended pressures.
7. Never connect or disconnect a hose or line containing pressure; it may whip. Never remove a component or plug unless you are certain all system pressure has been depleted.
8. Use only genuine Bendix® replacement parts, components and kits. Replacement hardware, tubing, hose, fittings, etc. must be of equivalent size, type and strength as original equipment and be designed specifically for such applications and systems.

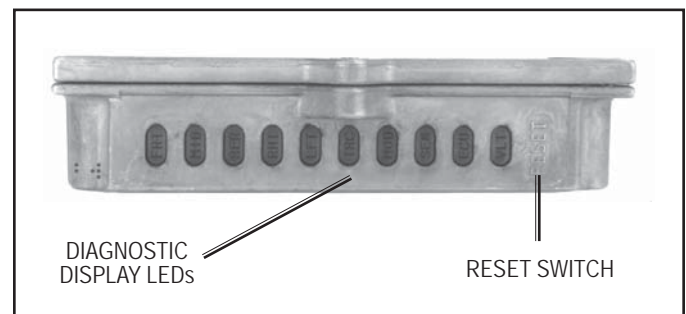

FIGURE 7 - EC-16™ CONTROLLER DIAGNOSTIC DISPLAY

9. Components with stripped threads or damaged parts should be replaced rather than repaired. Do not attempt repairs requiring machining or welding unless specifically stated and approved by the vehicle and component manufacturer.
10. Prior to returning the vehicle to service, make certain all components and systems are restored to their proper operating condition.
11. For vehicles with Antilock Traction Control (ATC), the ATC function must be disabled (ATC indication lamp should be ON) prior to performing any vehicle maintenance where one or more wheels on a drive axle are lifted off the ground and moving.

## REMOVING THE EC-16™ CONTROLLER

### EC-16™ CONTROLLER MOUNTED ON ANTILOCK RELAY VALVE OR ANTILOCK TRACTION RELAY VALVE

1. Identify and remove all air lines connected to the unit.
2. Disconnect the electrical connector(s) from the EC-16™ controller.
3. Note and mark the mounting position of the assembly on the vehicle. Loosen, remove and save the nuts on the mounting hardware that attaches the controller relay assembly bracket to the vehicle. Remove the relay valve and EC-16™ controller from the vehicle.

4. Remove as much contamination as possible from the assembly's exterior. Keep the contamination away from the open ports.
5. Note and mark the position of the EC-16™ controller relative to the valve it is mounted on. Remove and retain the four cap screws that secure the EC-16™ controller to the valve. Then separate the EC-16™ controller from the valve.

### **BRACKET MOUNTED EC-16™ CONTROLLER**

1. Disconnect the electrical connector(s) from the EC-16™ controller.
2. Note and mark the mounting position of the EC-16™ controller on the vehicle. Loosen, remove and save the nuts on the mounting hardware that attaches the EC-16™ controller bracket to the vehicle. Remove the EC-16™ controller and bracket from the vehicle.
3. Remove and retain the four cap screws that secure the EC-16™ controller to the bracket. Separate the EC-16™ controller from the bracket.
4. Perform the "Initial Start up Procedure" in the TROUBLESHOOTING section to assure proper system operation.

### **INSTALLING THE EC-16™ CONTROLLER**

#### **EC-16™ CONTROLLER MOUNTED ON ANTILOCK RELAY VALVE OR ANTILOCK TRACTION RELAY VALVE**

1. After noting the relationship of the positioning marks made prior to disassembly, position and secure the EC-16™ controller to the valve using the four cap screws. Torque the cap screws to 50-80 lbs. in.
2. Mount the assembled EC-16™ controller and antilock relay valve on the vehicle and orient it in the position marked before removal.
3. Reconnect all air lines to the assembly.
4. Reconnect the electrical connector(s) to the EC-16™ controller.
5. Test the valve for operation and leakage prior to placing the vehicle in service.
6. Perform the "Initial Start Up Procedure" in the TROUBLESHOOTING section to assure proper system operation.

### **BRACKET MOUNTED EC-16™ CONTROLLER**

1. Secure the EC-16™ controller to its bracket using the four cap screws. Torque to 50-80 lbs. in.
2. After noting the positioning marks, mount the EC-16™ controller on the vehicle using the mounting hardware retained during removal.
3. Connect the electrical connector(s) to the EC-16™ controller.

4. Perform the "initial Start up Procedure" in the TROUBLESHOOTING section to assure proper system operation.

## **DIAGNOSING AND LOCATING A SYSTEM PROBLEM**

### **GENERAL**

The EC-16™ controller contains self test and diagnostic circuitry that continuously checks for proper operation of the entire antilock/traction system, including wiring continuity. The EC-16™ controller is programmed at the factory to accommodate the needs of the vehicle and the customer's desires. All EC-16™ controllers are not factory programmed with the traction control feature, in which case antilock only will be active. The newer, self configuring EC-16™ controller can be reconfigured by the end user to include traction control. A vehicle equipped with traction control can generally be identified by noting the presence of a dashmounted condition lamp, a disable switch (for the traction control system) and a traction solenoid located above the relay valve.

Separate dash lamps, controlled by the EC-16™ controller, advise the driver of the condition of the entire antilock/traction system. The condition of specific components is provided by a series of labeled, light emitting diodes (LEDs) in the EC-16™ controller housing. No special tools or equipment are needed to read or interpret the EC-16™ controller diagnostic display. It should be noted that the EC-16™ controller diagnostics display is separate from the antilock and traction condition lamps on the dash. With this separation, the driver is aware of any problems that occur but is not confused by diagnostic information.

When the controller senses an erroneous condition, it stores the condition in memory, disables the antilock or traction function, and illuminates the dash mounted condition lamp and the appropriate diagnostic LEDs on the EC-16™ controller. The failure condition is truly stored and is not cleared by loss of power to the EC-16™ controller. The LEDs will relight when power is restored and remain illuminated until the failure is corrected. After the actual problem is corrected, maintenance personnel can clear or reset the EC-16™ controller diagnostics by holding a small magnet over the RESET point in the diagnostics display.

### **DIAGNOSTIC LEDS**

There are ten LEDs plus a magnetically actuated reset switch in the EC-16™ controller diagnostic display. The first six LEDs locate a problem to a specific area of the vehicle, and the next three indicate the problem component or its wiring. The LEDs are software driven and are either ON or OFF depending upon their monitor function. (Note: right and left, front and rear are determined from the driver's seat.)

FRT	Red LED
MID	Red LED (See Note)
RER	Red LED
RHT	Red LED
LFT	Red LED
TRC	Red LED
MOD	Red LED
SEN	Red LED
ECU	Red LED
VLT	Green LED
RESET +	No LED

**Note:** The MID LED is used with some but not all vehicles. When six speed sensors are not installed this LED is not used in the diagnostic process. However, it will light when a magnet is placed on the RESET switch in the diagnostic display.

#### “FRT” (Front) LED

This Red LED illuminates and latches ON in order to indicate the location of a problem component or its wiring. It will light in conjunction with either the RIGHT or LEFT LED and the MOD or SENS LED.

#### “MID” (Mid Axle) LED

This Red LED is not used in all installations. On those vehicles that have six speed sensors installed, this Red LED illuminates and latches ON to indicate the location of a problem speed sensor or its wiring. The “MID” LED should not illuminate with the “MOD” LED.

#### “RER” (Rear) LED

This Red LED illuminates and latches ON in order to indicate the location of a problem component or its wiring. It will light in conjunction with either the RIGHT or LEFT LED and the MOD or SENS LED

#### “RHT” (Right) LED

This Red LED illuminates and latches ON in order to indicate the location of a problem component or its wiring. It will light in conjunction with either the FRONT or REAR LED and the MOD or SENS LED.

#### “LFT” (Left) LED

This Red LED illuminates and latches ON in order to indicate the location of a problem component or its wiring. It will light in conjunction with either the FRONT or REAR LED and the MOD or SENS LED.

#### “TRC” (Traction) LED

This Red LED illuminates and latches ON to indicate a permanent problem in the traction control system. It may be illuminated with the MOD LED or may illuminate by itself. NOTE: If an intermittent problem exists with the wiring to the engine control module (ECM), this LED will go on. However, it will not latch—it will go out when the problem “corrects” itself.

#### “MOD” (Modulator) LED

This Red LED illuminates and latches ON to indicate a permanent or intermittent open or short circuit in the solenoids of one of the four M-21™ modulators or the wiring connecting them to the system. When indicating a problem with an M-21™ modulator this LED will be illuminated with two positioning LEDs (RHT/LFT + FRT/RER). NOTE: The MID positioning LED should not be illuminated with this LED. This LED is also used to indicate a problem with an ATR-1™ or ATR-2™, antilock traction relay, solenoid. When illuminated for a traction system problem the TRC LED will also be on.

#### “SEN” (Speed Sensor) LED

This Red LED illuminates and latches ON to indicate permanent or intermittent failure. The failures indicated are; open or shorted wheel does not conform to design criteria. The “SEN” LED will be illuminated with two positioning LEDs (RHT/LFT + FRT/MID/RER).

#### “ECU” (Electronic Control Unit) LED

This Red LED, when illuminated, indicates that the controller itself has failed. It is latched ON for all EC-16™ controller failures except low voltage. Before controller replacement is considered, always check vehicle voltage to the controller.

#### “VLT” LED

This Green LED illuminates and remains ON during vehicle operation to indicate that vehicle power is reaching the controller. If vehicle power is out of range (below 11 VDC or above 17 VDC) this LED will flash until power is brought into range.

#### “RESET”

Beneath the RESET area of the display is a magnetically sensitive switch that is used to reset the diagnostic system. The device will respond to a magnet which has strength sufficient to lift a three (3) ounce weight. Momentarily holding a magnet against the RESET will cause ALL LEDs to light during the time the magnet is against it. Holding a magnet against the RESET longer than 20 seconds will cause the newer version EC-16™ controller to initiate the self configuration feature.

## EC-16™ CONTROLLER CONFIGURATION

### GENERAL

All EC-16™ controllers manufactured on or after August 1, 1995 incorporate the self configuring feature. New, replacement EC-16™ controllers will be provided factory preprogrammed for 6 speed sensor inputs and both the differential braking and torque limiting features for traction control.

ANTILOCK LAMP	LAMP ON 1ST TIME	LAMP OFF 1ST TIME	LAMP ON 2ND TIME	LAMP OFF 2ND TIME	LAMP ON STAYS ON
Traction Lamp (EC-16™ controller w/torque limiting & differential braking)	On	Off	On	Off	Stays Off
Traction Lamp (EC-16™ controller w/torque limiting only)	Off	Off	On	Off	Stays Off
Traction Lamp (EC-16™ controller w/differential braking only)	On	Off	Off	Off	Stays Off

## IDENTIFYING THE SELF CONFIGURING EC-16™ CONTROLLER

The self configuring EC-16™ controller can most easily be identified while installed on the vehicle. Identification can be made by observing the reaction of the diagnostic display when the ignition is switched ON and power is applied to the EC-16™ controller. The current configuration of the EC-16™ controller is displayed via the troubleshooting LEDs and occurs during the normal self test sequence. This configuration review is repeated each time the ignition is turned on. The sequence and manner of LED illumination is described in the section entitled EC-16™ Controller Configuration Display. That section should also be used to confirm that the system is configured as desired.

The diagnostic LEDs on older versions of the EC-16™ controller will only react as described in items 2 and 6 under the section entitled EC-16™ Controller Configuration Display.

## EC-16™ CONTROLLER CONFIGURATION DISPLAY

- Turn the ignition ON.
- All LEDs will illuminate then go out.
- The number of active sensors will be displayed by the momentary illumination of the red SEN (sensor) LED and two or more of the red locating LEDs. No other LEDs will be on.
  - SEN + FRT (front) + RER (rear) = A four sensor configuration (all systems must have at least a 4 sensor configuration)
  - SEN + FRT + MID (middle) + RER = A six sensor configuration
- The red TRC LED will momentarily illuminate by itself if traction control torque limiting is active, if not, then the display will go to the condition described in #5.
- The red TRC and MOD LEDs will momentarily illuminate if traction control differential braking is active, if not, then the display will go to the condition described in #6. No other LEDs will be on.
- The diagnostic display will return to its normal operational status. Assuming no problems exist in the antilock or traction system, all red LEDs will be off and the single, green, VLT LED is illuminated.

## EC-16™ CONTROLLER SELF CONFIGURING PROCESS

### Important General Information

- Three aspects of the antilock and traction system are influenced by the self configuring feature of the EC-16™ controller.
  - Speed Sensors** The number of speed sensors connected to the EC-16™ controller will be detected during the self configuration process. The EC-16™ controller will check the MID SEN (mid axle speed sensor) locations on its connector to determine if a sensor is connected to it and will default to a six sensor configuration if it detects even one sensor connected. If no mid axle speed sensor is detected, the EC-16™ controller will default to a four sensor configuration.
  - Electronic Engine Control** If the EC-16™ controller is connected to the control module of an electronic engine, the torque limiting feature of traction control will be activated during the self configuring process.
  - Antilock Traction Relay Valve** If the solenoid assembly in the ATR valve is connected to the EC-16™ controller, the differential braking feature of traction control will be activated during the self configuring process.
- No method is available to disable the self configuration feature.
- Due to the extended period of time the magnet must be held on the RESET to initiate the self configuration process (20 seconds), it is unlikely that a self configuration would occur accidentally.
- Basic, four speed sensor, antilock operation can not be removed during the self configuration process. This is a minimum configuration for all EC-16™ controllers.
- If a speed sensor is connected to either wheel on the mid axle the EC-16™ controller will configure for six sensors. If no mid axle speed sensor is detected, the EC-16™ controller will configure for four sensors. Any disconnected speed sensor(s) will register as a failure on the diagnostic display at the end of the EC-16™ controller self test.



6. All or part of traction control can be lost during self configuration by;
  - A. Not connecting one of the wire harnesses (engine control module for torque limiting and ATR valve solenoid for differential braking)
  - B. A missing or inoperative traction dash lamp (bulb missing or burned out).
  - C. A missing or inoperative traction control enable disable switch.
  - D. Not placing the traction control enable / disable switch in the disabled position. The operator can tell that the traction features are lost by noting the absence of the traction lamp flash upon power up. The operator should note the flashing of the antilock condition lamp, and the traction lamp if traction equipped, upon every power up. Observing the dash lamps is the only method the operator has to verify the system operation.
7. The EC-16™ controller can be reprogrammed up to 10,000 times.
8. When a replacement EC-16™ controller is installed on a vehicle that does not have one or more of the pre-programmed features, a failure will be registered on the dash lamp(s) and on the EC-16™ controller diagnostic display. For this reason it is necessary to perform the self configuring procedure.
9. Some configuration information is available by observing the reaction of the dash condition lamps on vehicles configured with traction control and equipped with the self configuring EC-16™ controller. When the ignition is switched ON, the EC-16™ controller self test is begun. During the self test the dash lamps will flash on and off together as indicated in the chart, depending upon the type and amount of traction control configured into the EC-16™ controller. Note: For more information on this subject see the TROUBLESHOOTING section of this document.
2. If the vehicle is to be configured with traction control, it must have a traction control dash lamp and a traction control enable / disable switch. Both the lamp and switch must be functional. Place the traction control enable/disable switch in the traction control disabled position (traction control inoperative).
3. Turn the ignition ON and hold a magnet on the RESET position of the EC-16™ controller diagnostic display until the LEDs begin to randomly flash then remove the magnet. If the magnet is not removed during the random LED flashing a second self configuration may be initiated. The magnet may have to be held on the RESET for as long as 20 seconds. When the self configuration process is complete the EC-16™ controller will automatically go through a self test. During the self test the diagnostic display will indicate the new configuration as described under the section entitled EC-16™ Controller Configuration Display. Note: If the EC-16™ controller is being configured with traction control (either torque limiting, differential braking or both), the traction control condition dash lamp, will be illuminated as well as the appropriate LEDs on the EC-16™ controller diagnostic display. The traction control dash lamp will be illuminated until the traction control enable / disable switch is placed in the traction control enabled position (traction control operative).
4. Place the traction control enable / disable switch in the traction control enabled position (traction control operative), the traction control dash lamp should be off.
5. Before placing the vehicle in service, verify the configuration and the system condition by turning the ignition OFF then ON while observing the EC-16™ controller diagnostic display. The diagnostic display should indicate the desired configuration as described under the section entitled EC-16™ Controller Configuration Display and no red LEDs should be illuminated at the end of the self test.

### Self Configuration Process

In order to successfully complete the self configuring process follow the steps presented.

1. Connect all antilock and traction control wire harnesses. Refer to the schematic in Figure 4. Make certain that all the speed sensors present on the vehicle are connected (H2, H3, J1, J2 on the 30 pin connector and E2, E3, F2, F3, B2, B3, C2, C3 on the 18 pin connector). If the vehicle has an electronic engine and traction control torque limiting is desired the engine control module must be connected (B2 and B3 on the 30 pin connector). If the vehicle is equipped with either an ATR-1™ or ATR-2™ valve, the solenoid connection must be made to the EC-16™ controller (D2 and D3 on the 18 pin connector) in order to obtain traction control differential braking.
6. If the configuration appears correct but the diagnostic LEDs indicate a failure somewhere in the system, refer to the General Configuration Information below and use the Troubleshooting section of this manual to locate and repair the problem.
7. If the configuration is incorrect, the process can be repeated as required. One common error is performing the self configuration with the traction enable / disable switch in the wrong position. This will prevent any traction features from being activated. Note: The traction switch must be in the disable position to configure traction, but must be placed in the enable position to allow the traction lamp to flash.



## **TROUBLESHOOTING**

### **IMPORTANT BEFORE TROUBLESHOOTING:**

1. Determine if the vehicle is equipped with traction control. The presence of a traction condition lamp on the dash can be used.
2. Some vehicles are equipped with a traction control “disabling switch.” If so equipped, **ENABLE THE TRACTION SYSTEM BEFORE BEGINNING THE TROUBLESHOOTING.**
3. If the vehicle is equipped with traction control and is a tandem axle unit, note the number of drive axles. The “MID” diagnostic LED is used only on 6x4 vehicles.

### **GENERAL**

While the EC-16™ controller diagnostic display locates a specific problem area, it is still necessary to confirm whether the problem resides in the component itself or the wiring. The following troubleshooting procedure is devoted to narrowing the problem to either the wiring or a specific AntiLock or traction component. It should be noted that **ALL TROUBLESHOOTING BEGINS BY OBSERVING THE ANTILOCK AND TRACTION CONDITION LAMPS ON THE DASH.** All troubleshooting should begin by first performing the “Initial Start Up Procedure” and following the directions contained in it.

### **TROUBLESHOOTING TIPS**

1. Begin by observing the dash condition lamp(s) and performing the “Initial Start Up Procedure.”
2. The troubleshooting technician should record all findings and the action taken during the troubleshooting process.
3. No voltage or resistance tests are performed into the EC-16™ controller. All voltage and resistance tests are performed by beginning at the wire harness half of the connector and moving **AWAY** from the EC-16™ controller toward an antilock traction system component (modulator, wheel speed sensor, etc.)
4. If a problem mysteriously reoccurs and no apparent cause can be detected during troubleshooting, closely inspect the quality of the power supply to the antilock system. Check the vehicle wiring, wiring connectors **AND** the alternator. Defects in these components can cause false failure indications.

## DIAGNOSTIC DISPLAY QUICK REFERENCE

This index is presented for the benefit of personnel experienced in troubleshooting Bendix full-vehicle wheel control AntiLock with traction control. It provides a quick reference to specific sections that provide testing procedures and values.

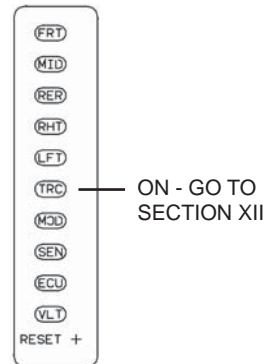
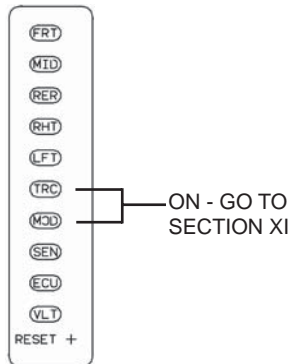
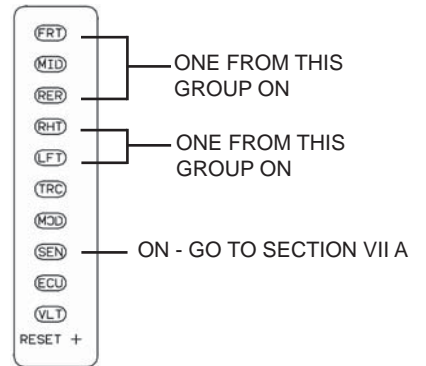
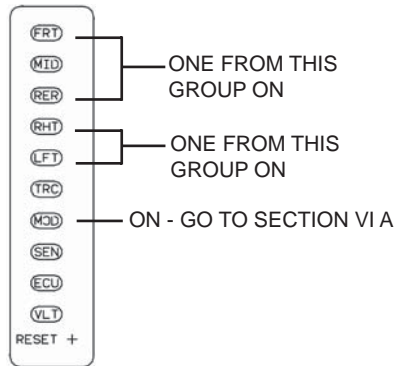
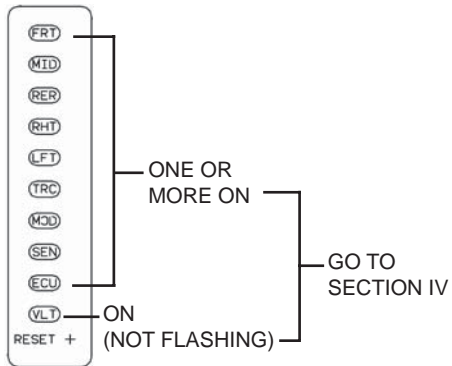
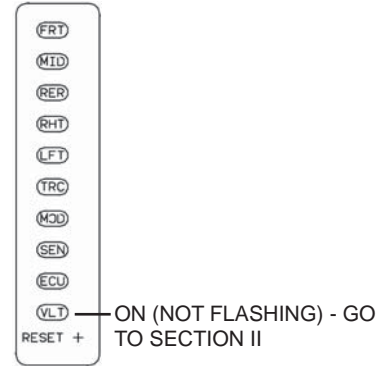
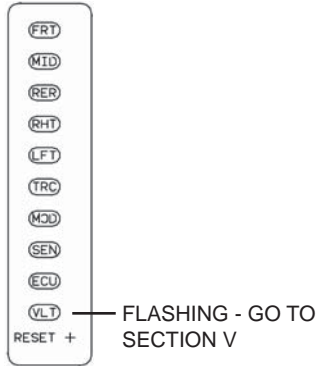
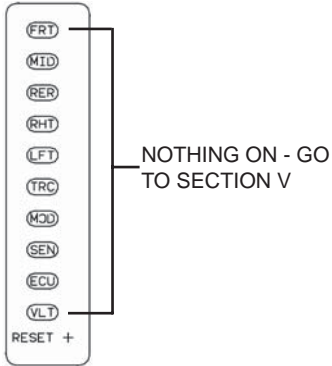

# INITIAL START-UP PROCEDURE

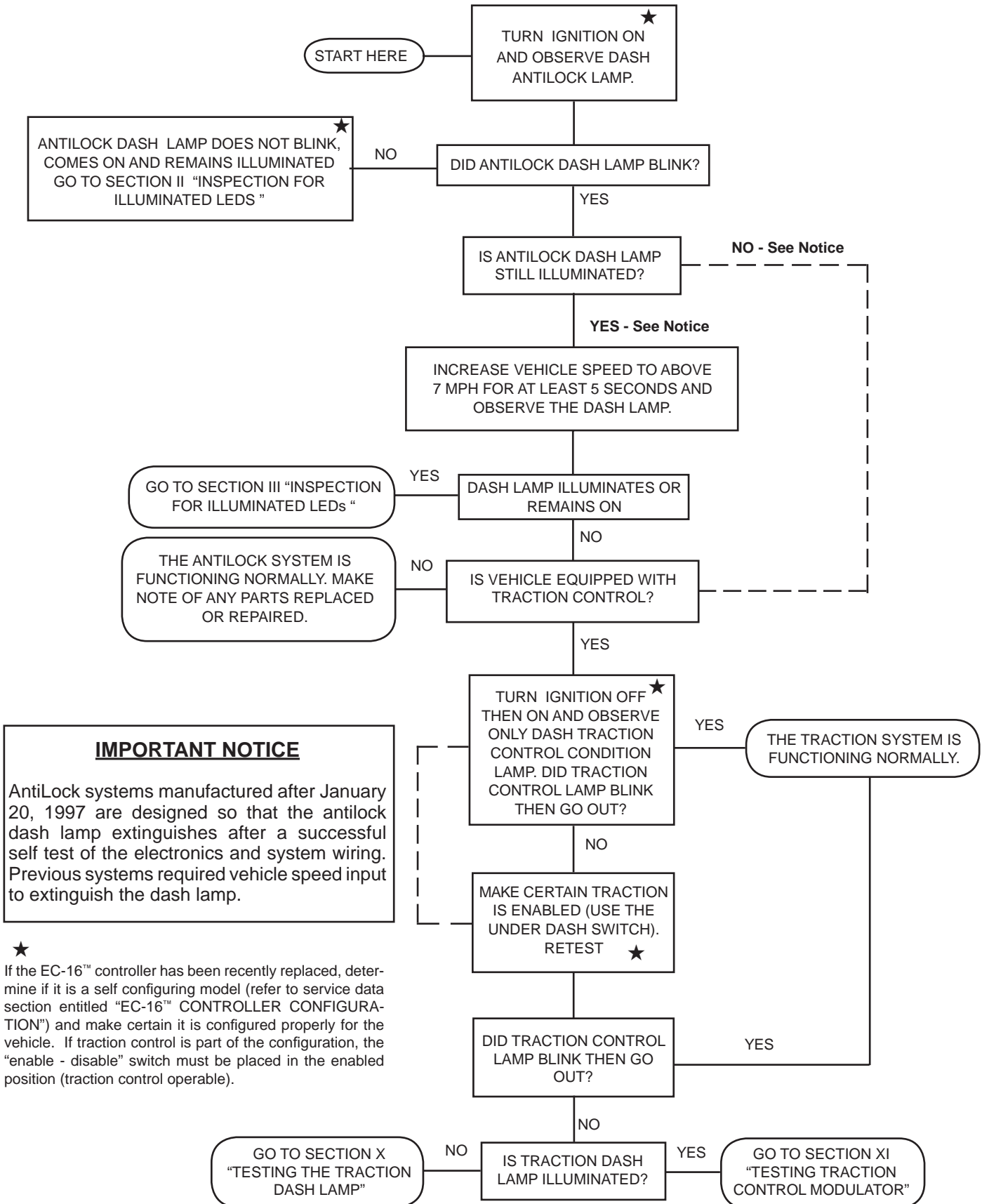

## IMPORTANT NOTICE

AntiLock systems manufactured after January 20, 1997 are designed so that the antilock dash lamp extinguishes after a successful self test of the electronics and system wiring. Previous systems required vehicle speed input to extinguish the dash lamp.



If the EC-16™ controller has been recently replaced, determine if it is a self configuring model (refer to service data section entitled "EC-16™ CONTROLLER CONFIGURATION") and make certain it is configured properly for the vehicle. If traction control is part of the configuration, the "enable - disable" switch must be placed in the enabled position (traction control operable).

## SECTION I - ANTILOCK DASH LAMP TESTING

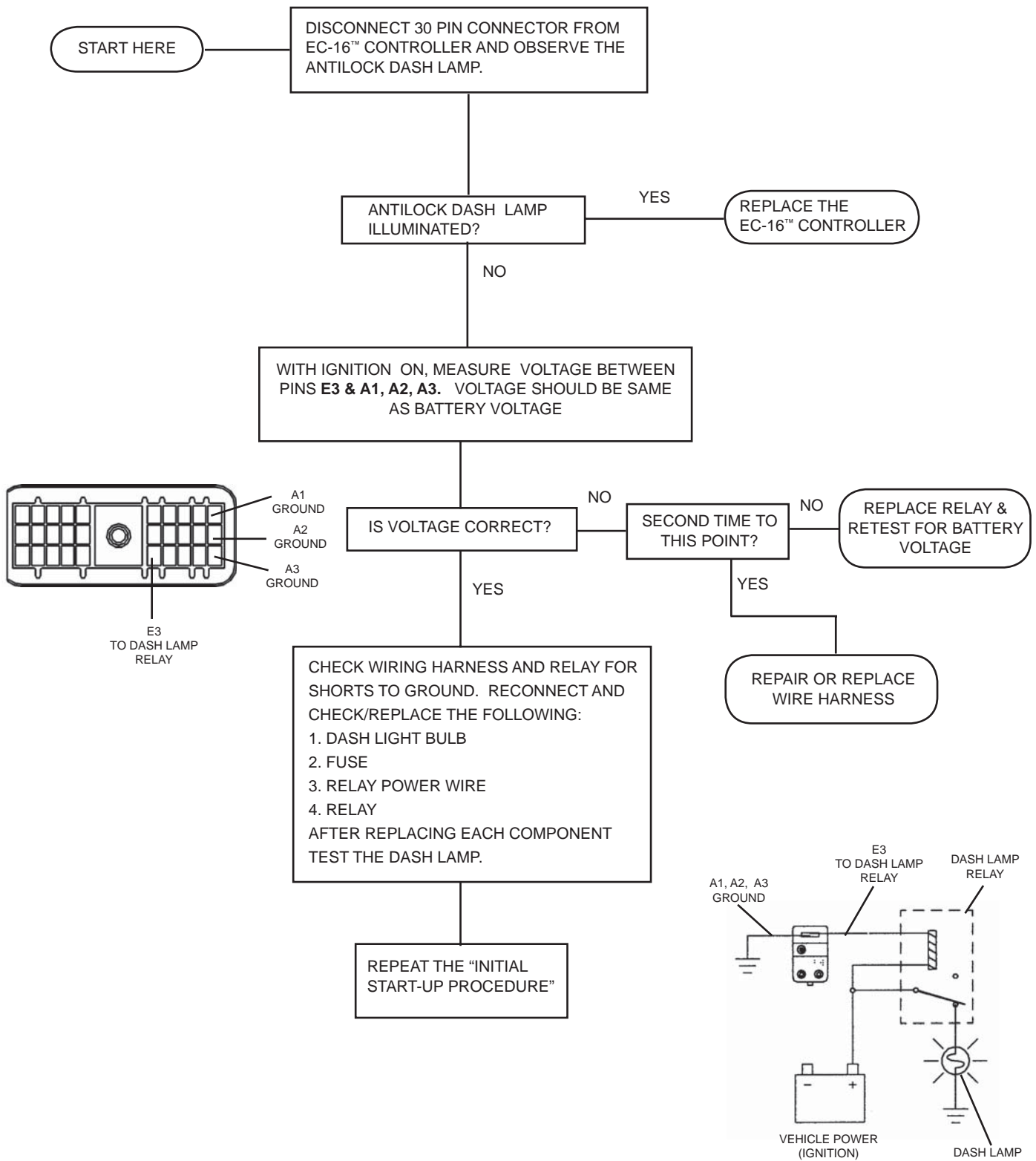

## SECTION II - INSPECTION FOR ILLUMINATED LEDs

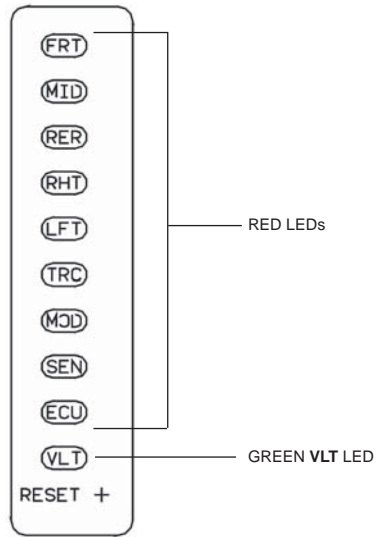
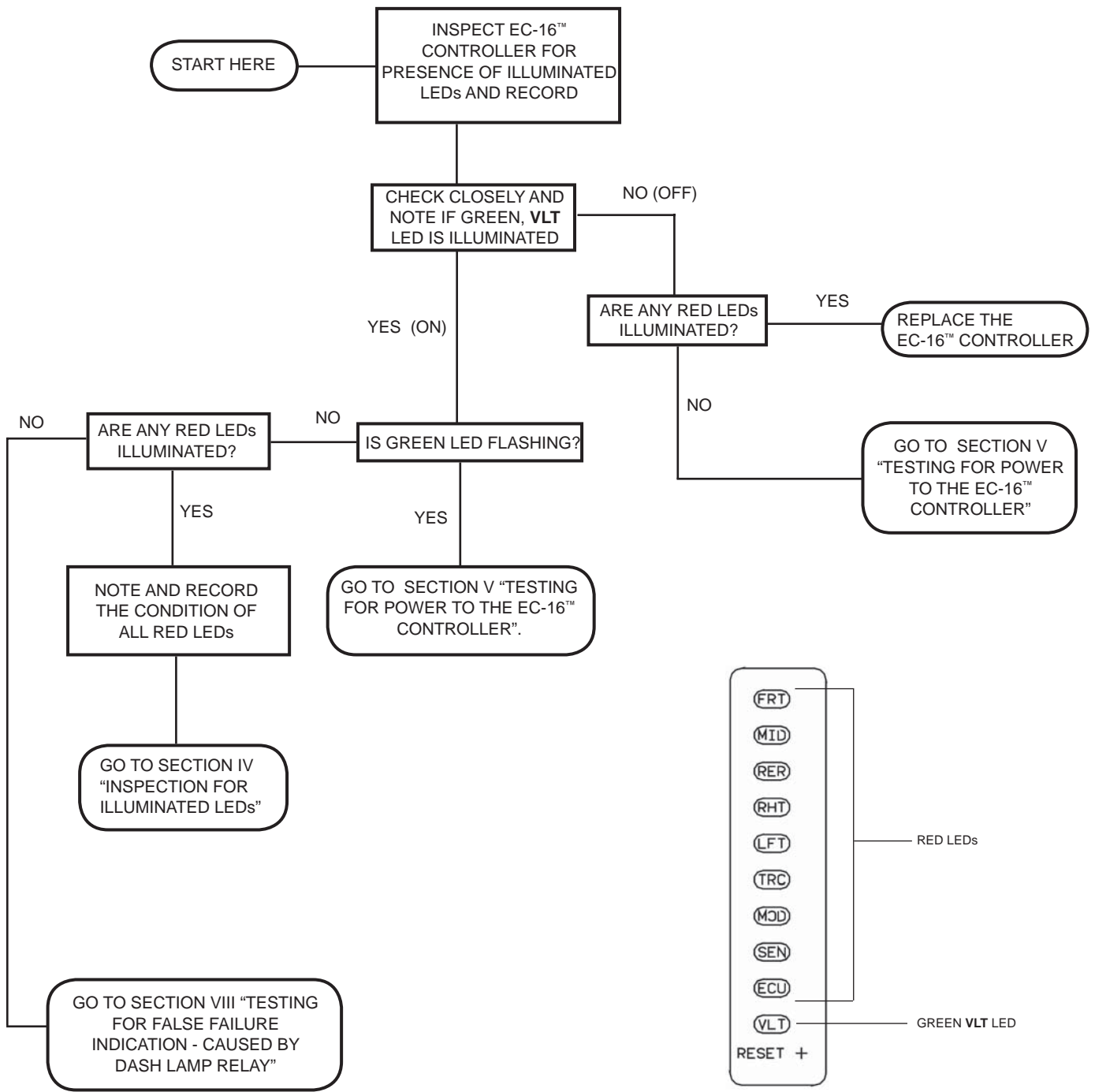

**EC-16™ CONTROLLER  
DIAGNOSTIC DISPLAY**



### SECTION III - INSPECTION FOR ILLUMINATED LEDs

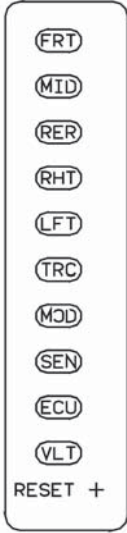
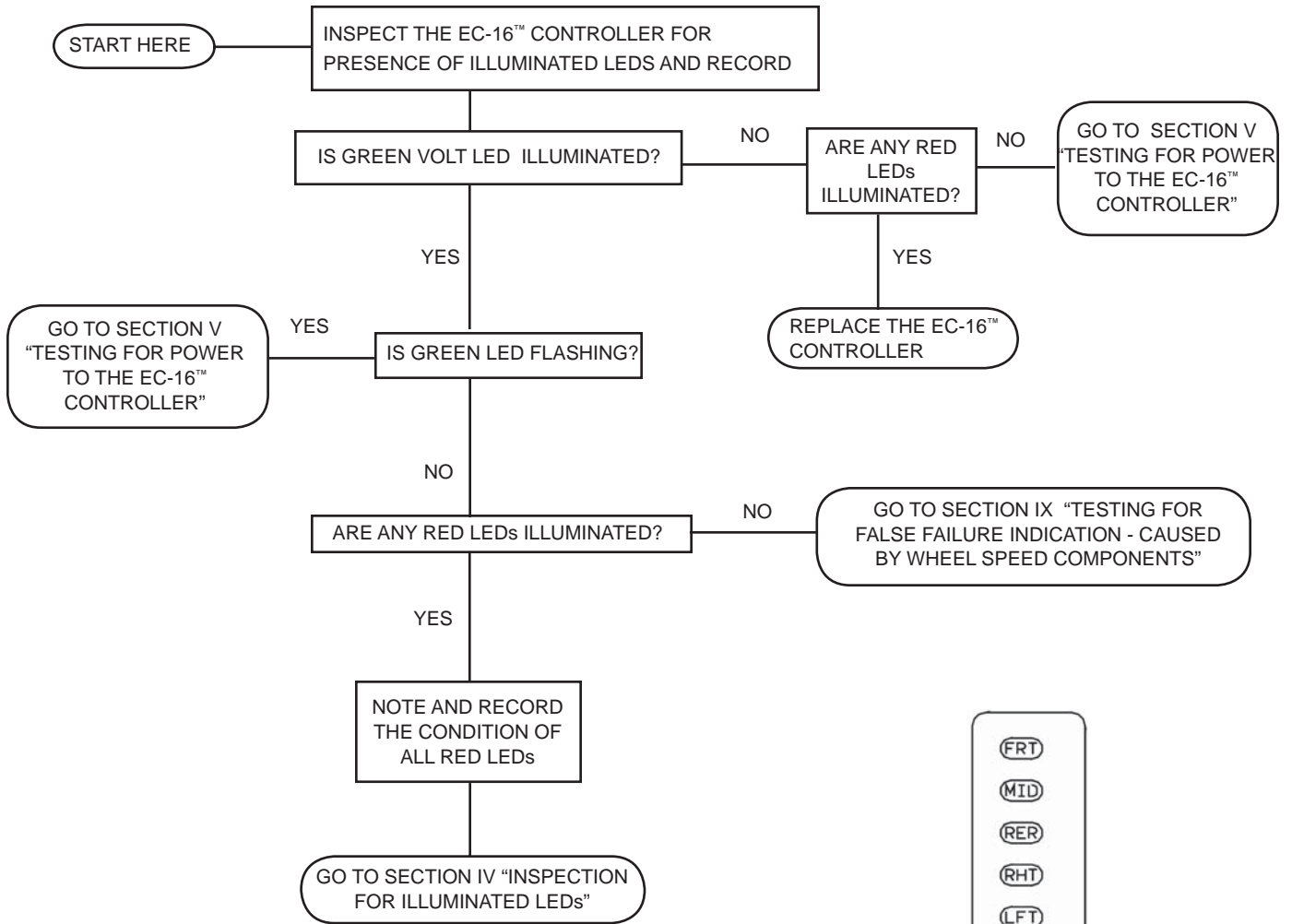

EC-16™ CONTROLLER  
DIAGNOSTIC DISPLAY

## SECTION IV - INSPECTION FOR ILLUMINATED LEDs

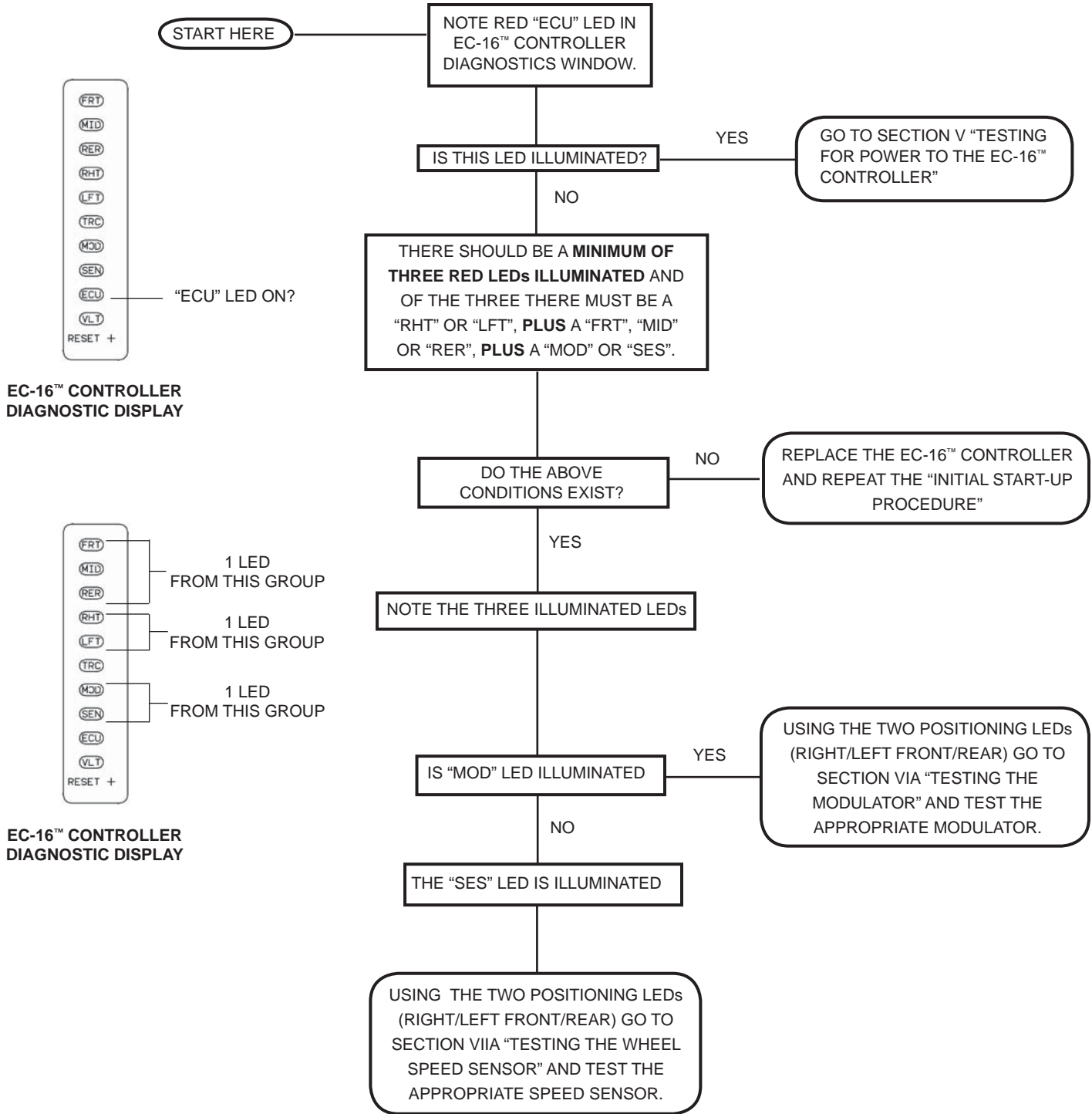

## SECTION V - TESTING FOR POWER TO THE EC-16™ CONTROLLER

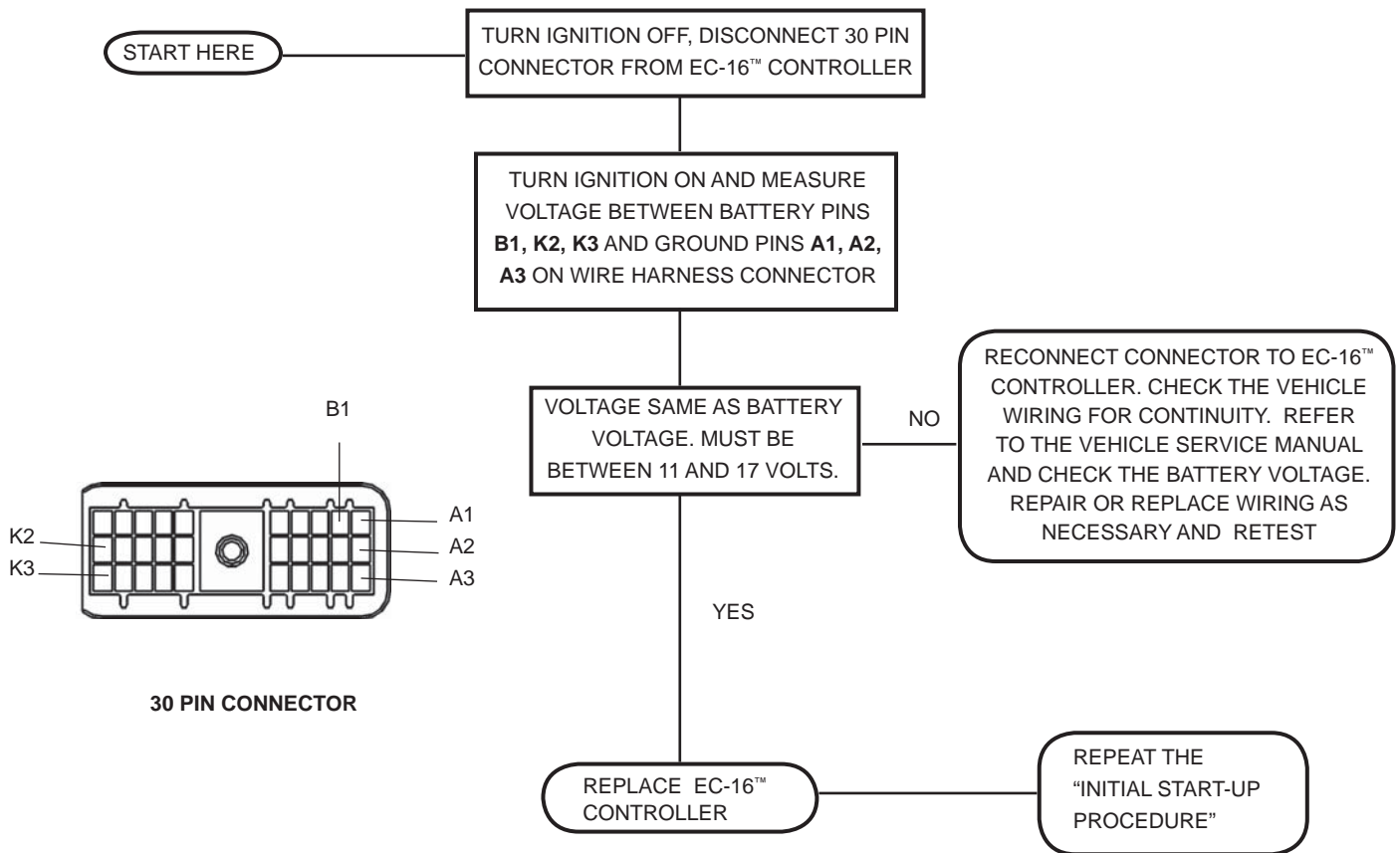

## SECTION VI A - TESTING THE MODULATOR

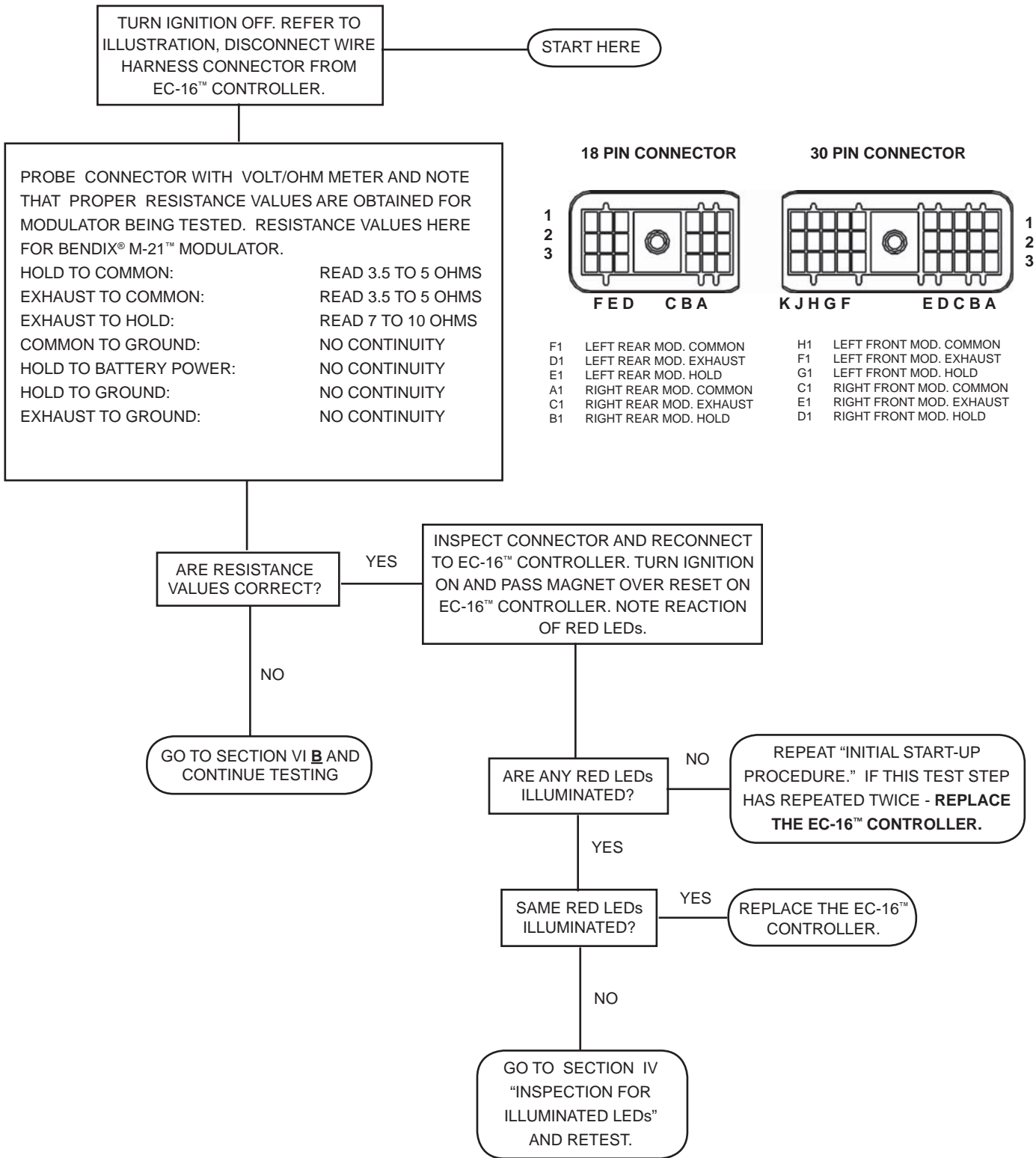

## SECTION VI B - TESTING THE MODULATOR

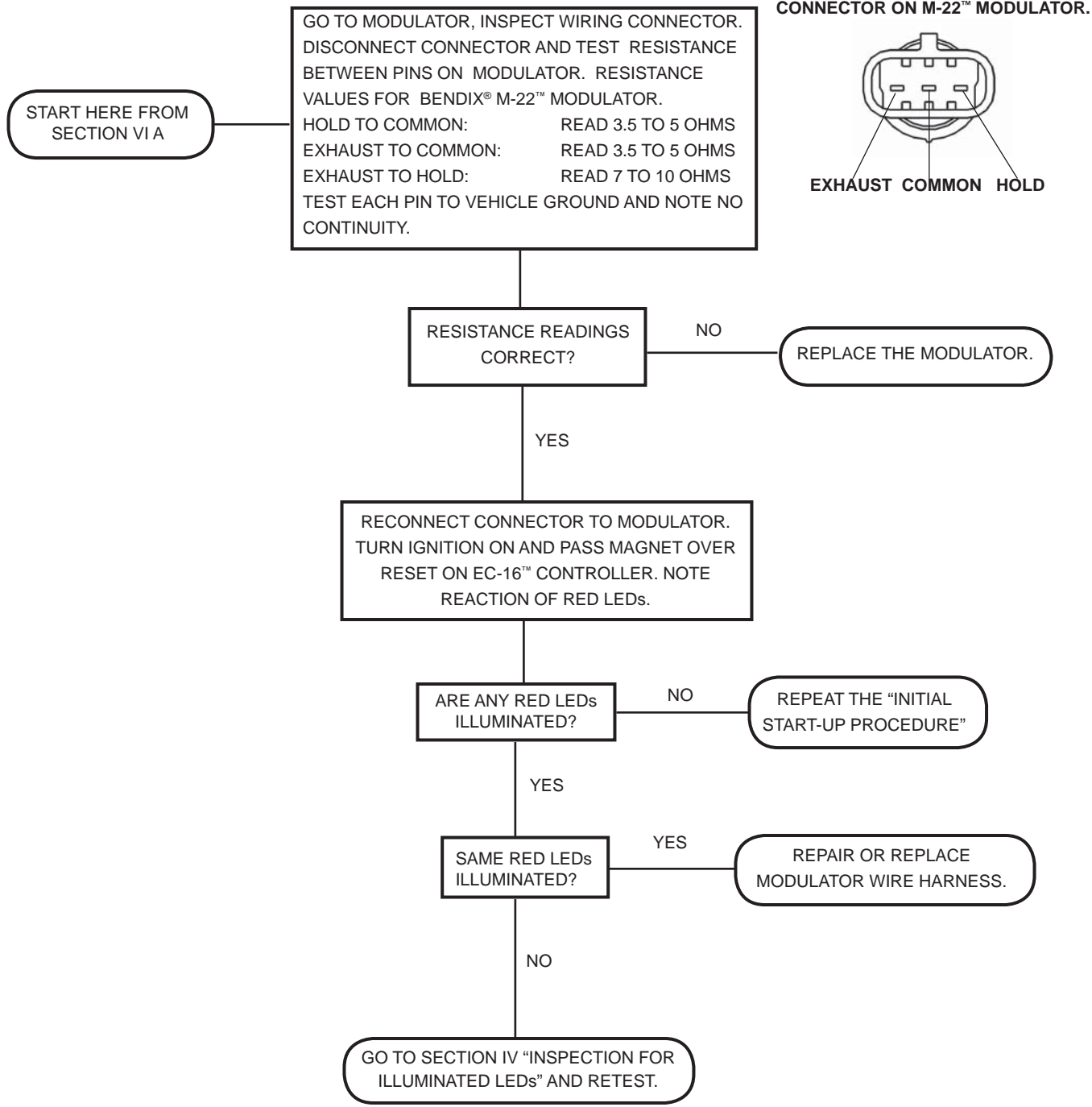



## SECTION VII A - TESTING THE WHEEL SPEED SENSOR

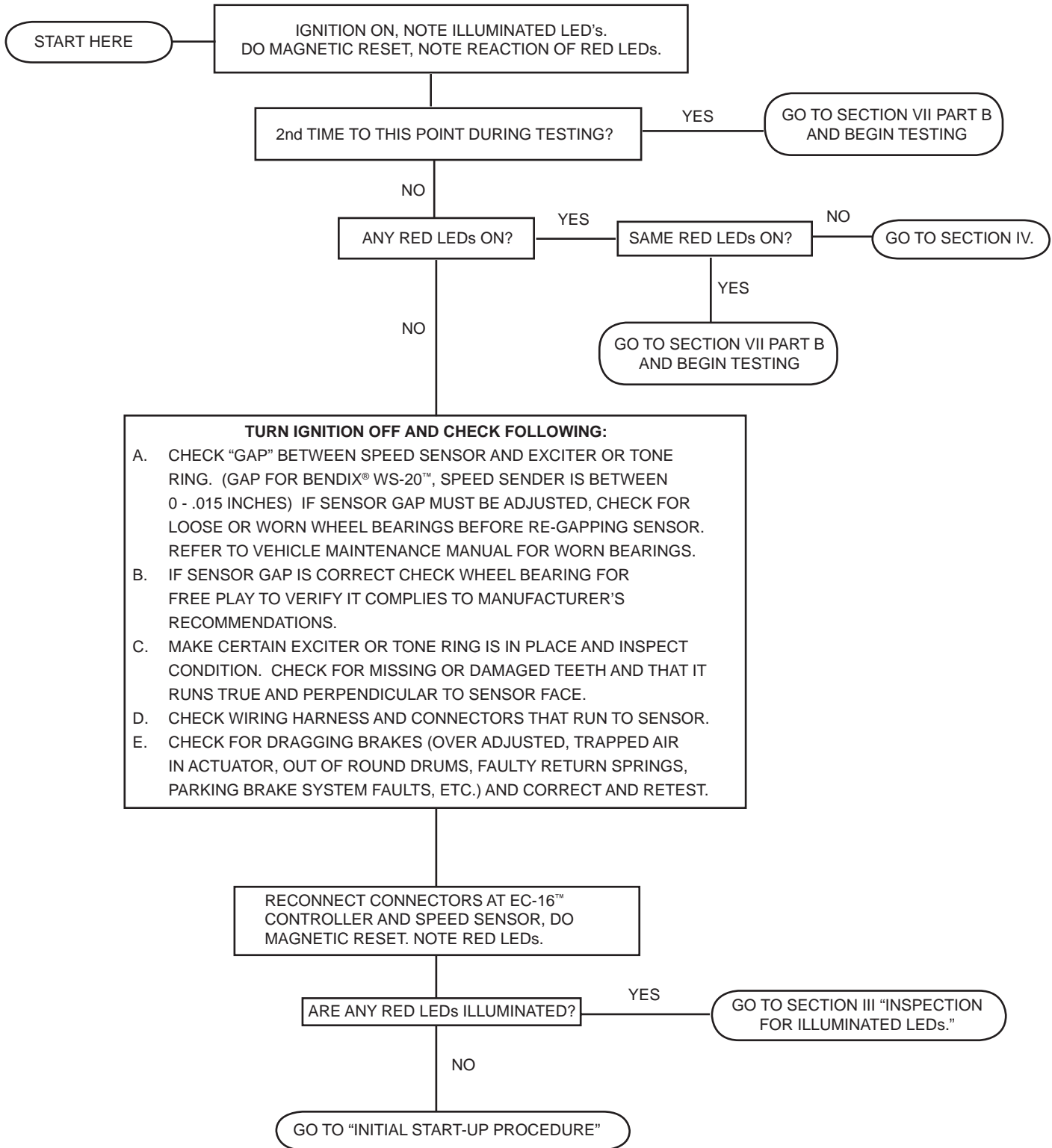

## SECTION VII B - TESTING THE WHEEL SPEED SENSOR

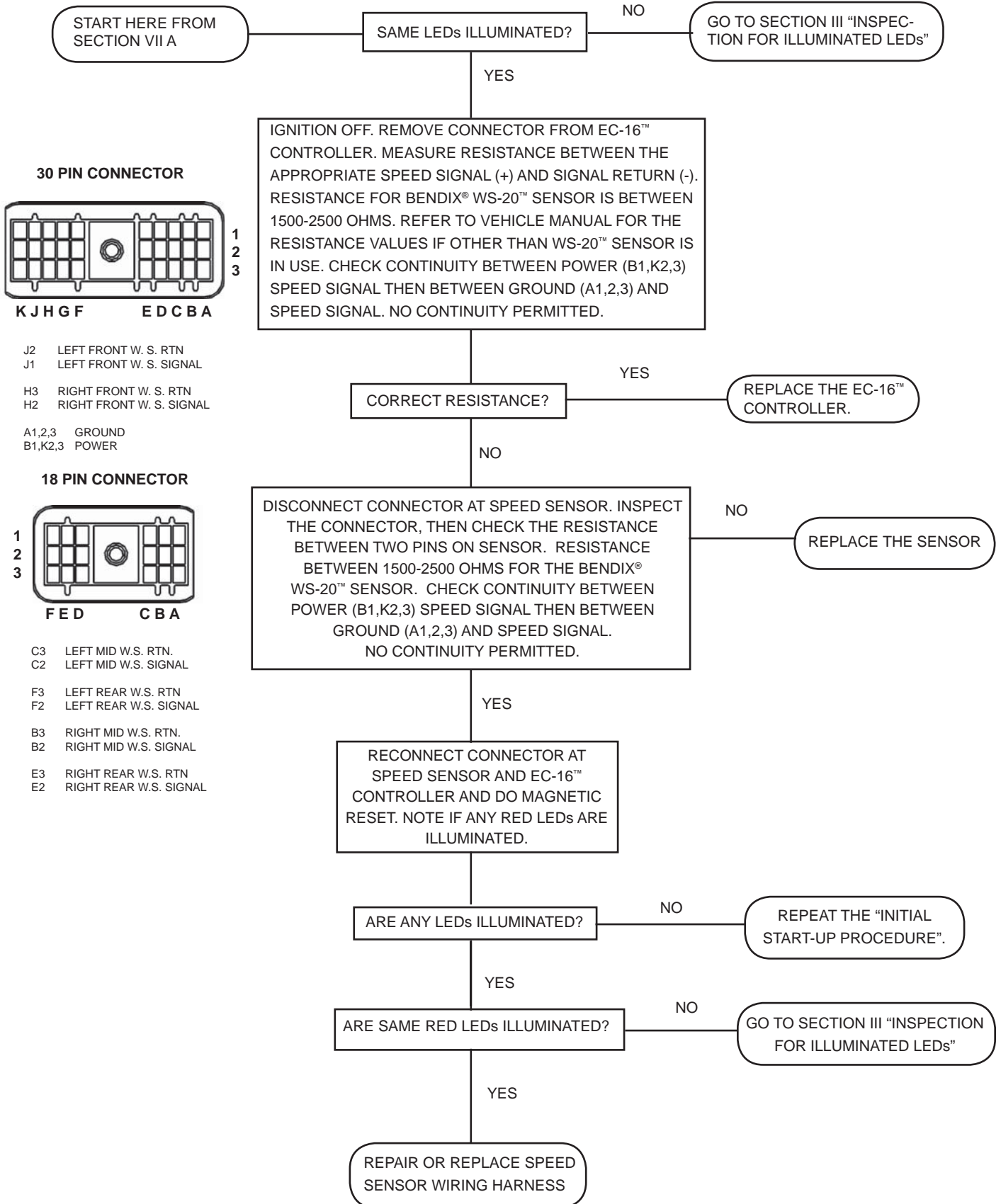

**30 PIN CONNECTOR**

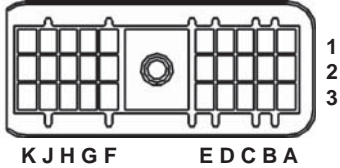

- J2 LEFT FRONT W. S. RTN
- J1 LEFT FRONT W. S. SIGNAL
- H3 RIGHT FRONT W. S. RTN
- H2 RIGHT FRONT W. S. SIGNAL
- A1,2,3 GROUND
- B1,K2,3 POWER

**18 PIN CONNECTOR**

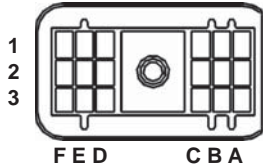

- C3 LEFT MID W.S. RTN.
- C2 LEFT MID W.S. SIGNAL
- F3 LEFT REAR W.S. RTN
- F2 LEFT REAR W.S. SIGNAL
- B3 RIGHT MID W.S. RTN.
- B2 RIGHT MID W.S. SIGNAL
- E3 RIGHT REAR W.S. RTN
- E2 RIGHT REAR W.S. SIGNAL

# SECTION VIII - TESTING FOR FALSE INDICATION CAUSED BY DASH LIGHT RELAY

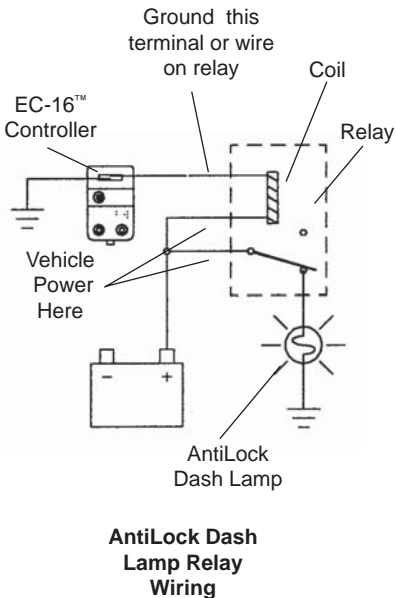
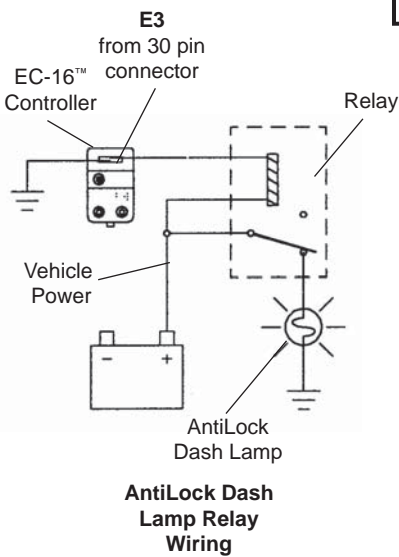
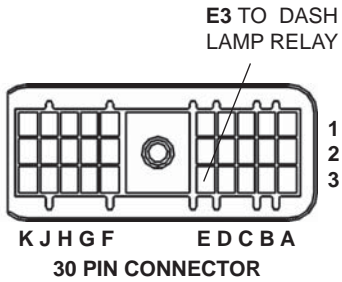
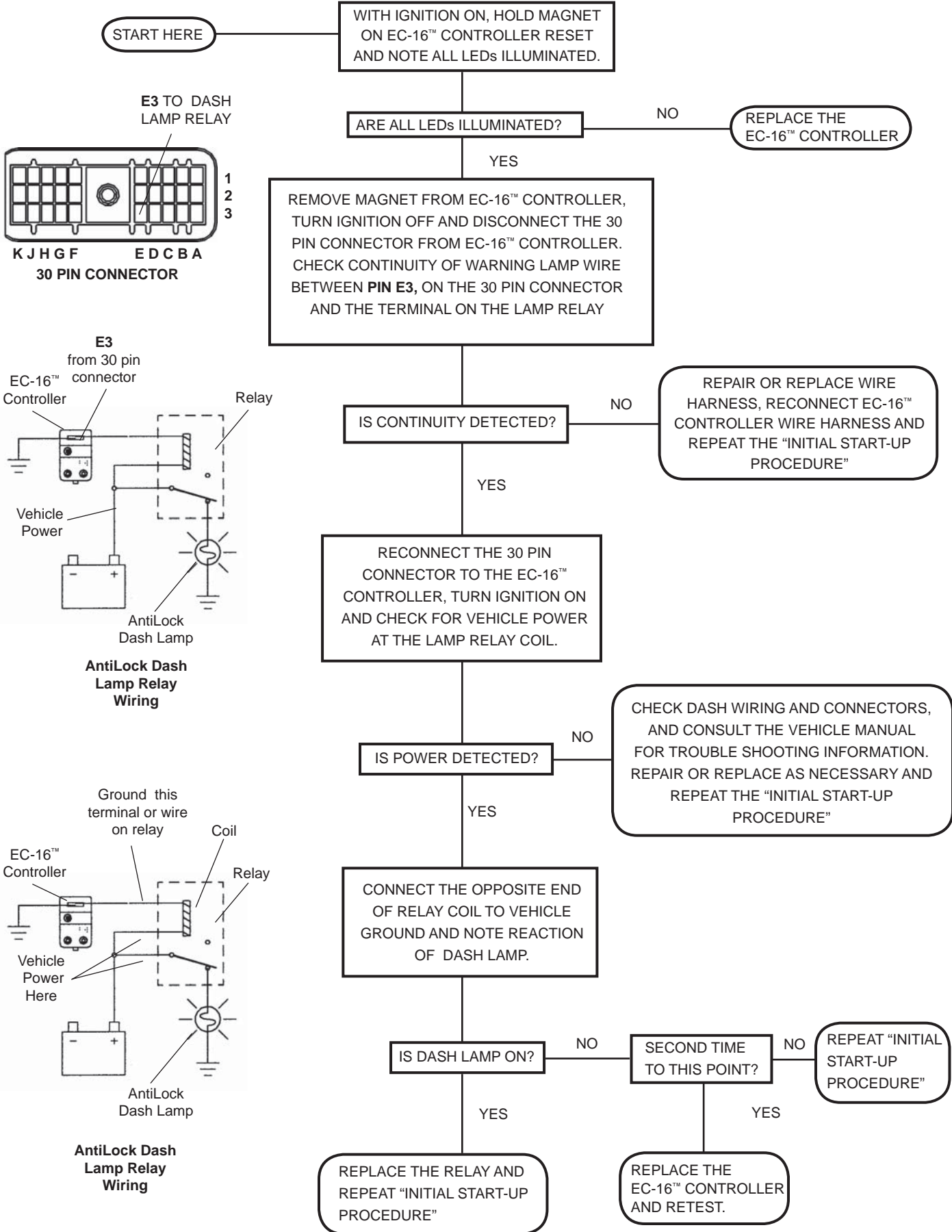

## SECTION IX - TESTING FOR FALSE INDICATION CAUSED BY WHEEL SPEED COMPONENTS

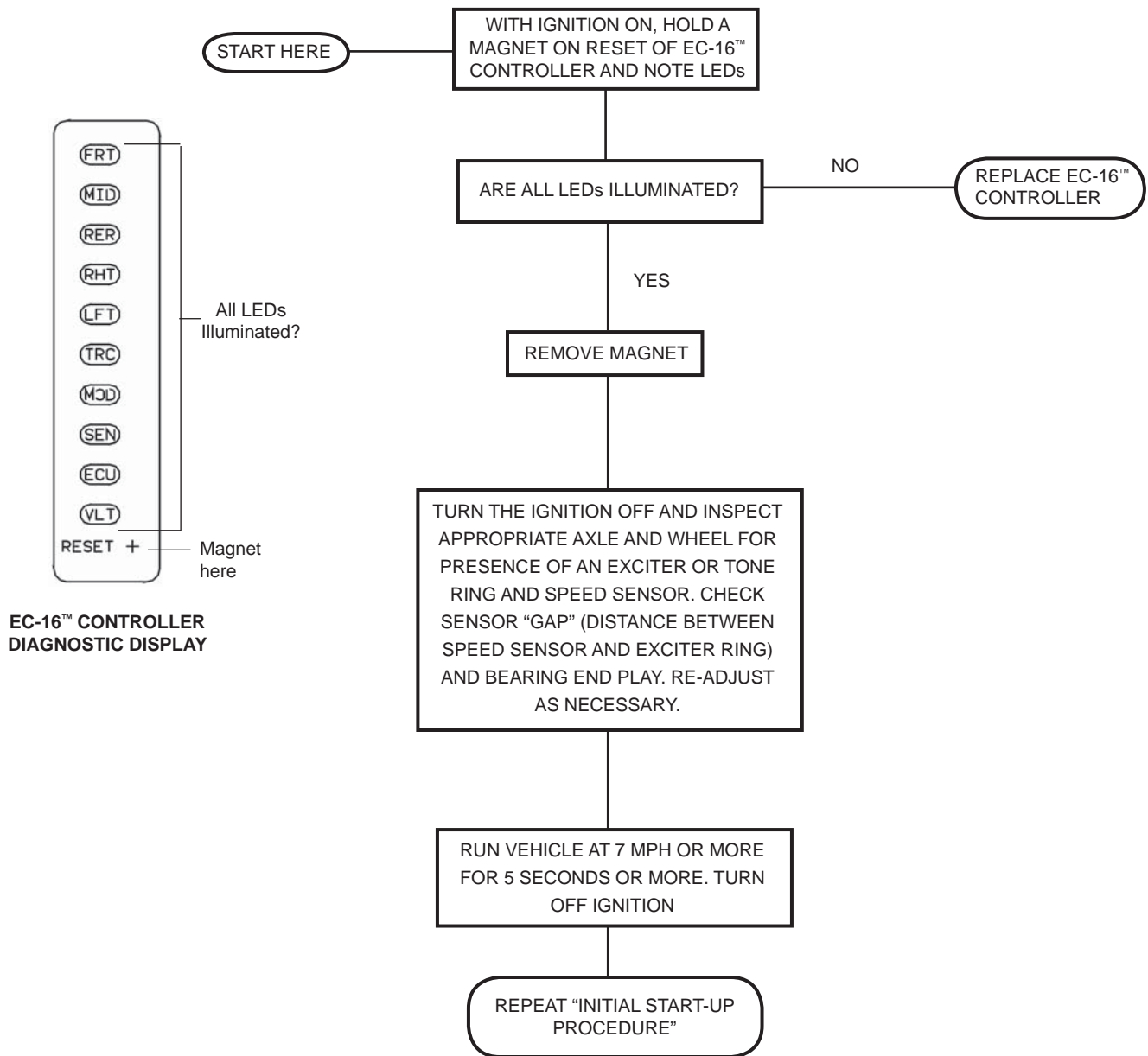

## SECTION X - TESTING TRACTION CONTROL DASH LAMP

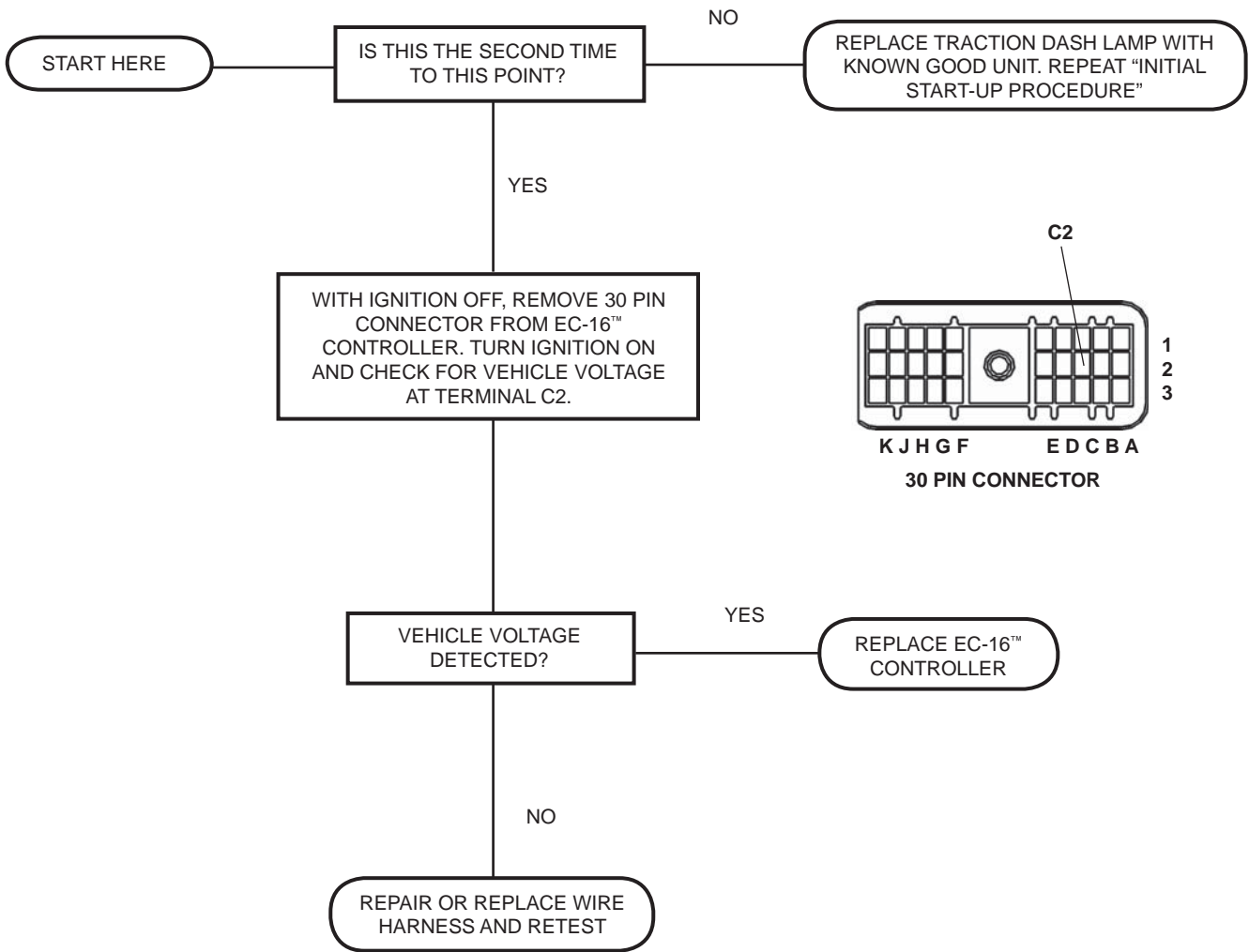

## SECTION XI - TESTING TRACTION CONTROL MODULATOR

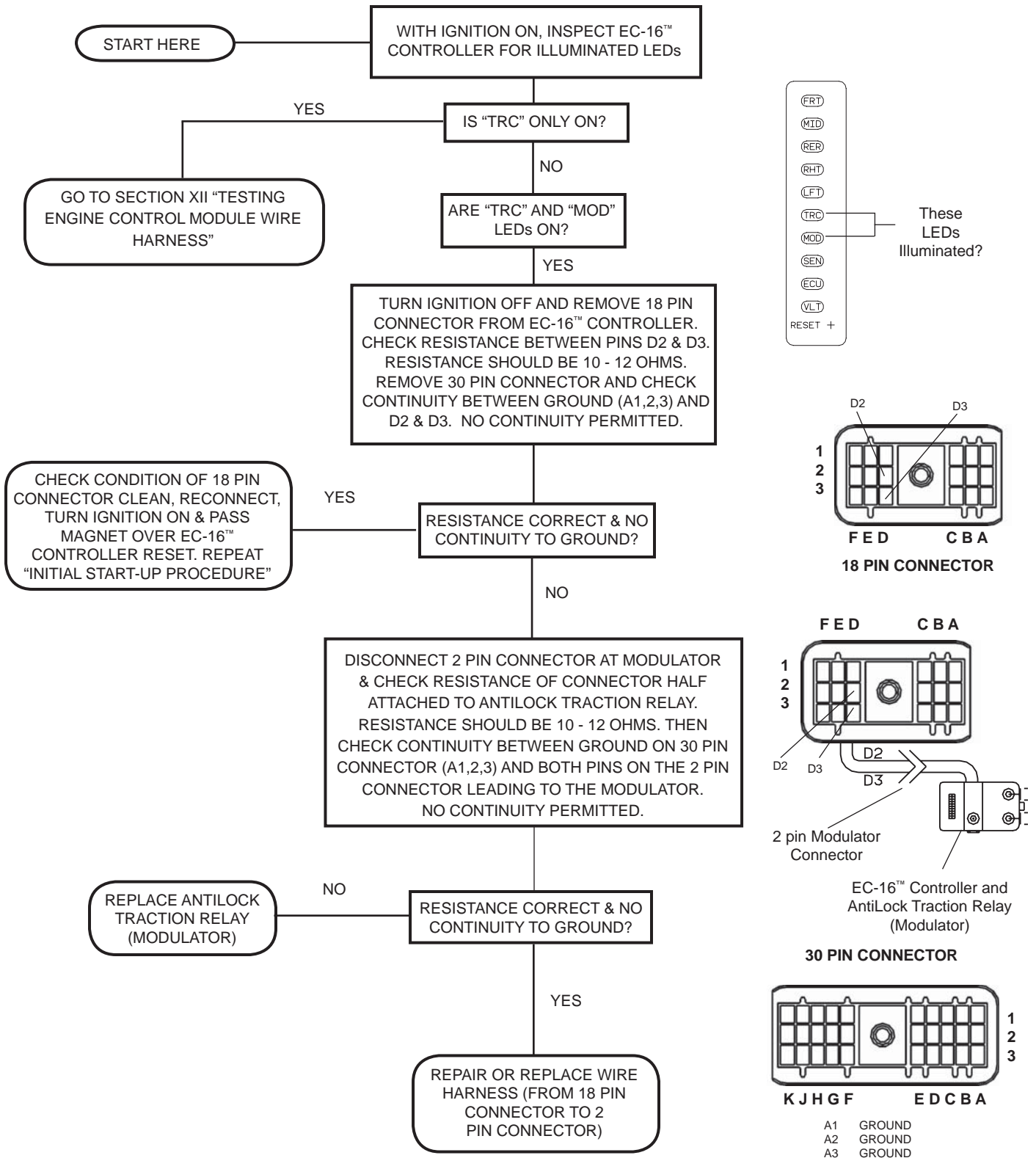



## SECTION XII- TESTING ENGINE CONTROL MODULE WIRE HARNESS

