

Function

All **Air Disc Brakes** are designed with a floating caliper and can be activated by either a brake chamber to provide the service brake function or a spring brake to provide the service and parking brake functions.

This range covers all vehicle applications with wheel sizes of 17.5" (SN5), 19.5" (SN6) and 22.5" (SN7, SK7 and ST7).

The new ST7 brake type is the further development of the SK7 to reduce more weight specifically for trailer applications with wheel sizes of 22,5". This brake, similar to the SK7, has 2 mm more brake pad thickness compared with the SN6 and SN7 versions.

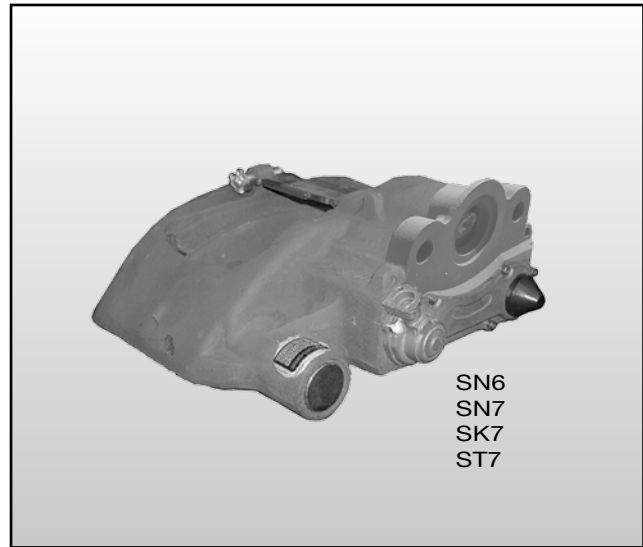

Main Features

- Monobloc caliper
- Compact design
- Reduced weight
- Optimised sealing at the caliper to actuator interface and the fixed guide pin
- Optimised protection of the guide pins, both bearings totally closed (SN7 / SK7 / ST7)
- Interchangeability between SN and SB
- Possibility of pad wear control via pad wear indicators

SN5..., SN6..., SN7..., SK7..., ST7...**Air Disc Brakes for Trailers**Doc. No. Y011373 (EN - Rev. 004)
March 2015**Technical Features**

	SN5	SN6	SN7	SK7	ST7
Suitable for wheel rim size [inch]	17.5	19.5	22.5	22.5	22.5
Internal transmission ratio	10.0	15.6	15.6	15.6	15.6
Brake disc diameter [mm]	335	374	430	430	430
Brake disc thickness (new) [mm]	34	45	45	45	45
Brake disc thickness (min.) [mm]	28	37	37	37	37
Pad friction material thickness (new) [mm]	19	21	21	23	23
Pad friction material thickness (min.) [mm]	2	2	2	2	2
Brake efficiency [%]	≥95	≥95	≥95	≥95	≥95
Weight without disc, including pads [kg] (may alter depending on variant)	24.0	33.5	41.5	36.6	31.5
Sealing boot (disc brake caliper to actuator interface)	Yes	Yes	Yes	Yes	Yes

Further information on air disc brakes, discs and actuators, as well as brake pads, service kits and service tools can be found in:

*Service Manual SN5 (Document No. Y015044**

*Service Manual SN6, SN7, SK7 (Document No. Y006471**

*Service Manual ST7 (Document No. Y173241**

* - Refer to website www.knorr-bremsecvs.com for latest revision.

Revision Details

Rev. 003 March 2011 New layout for revised Trailer Catalogue

Rev. 004 March 2015 ST7 added

**KNORR-BREMSE**

The information contained herein is subject to alteration without notice and therefore may not be the latest release. Please check our website www.knorr-bremsecvs.com for the latest update or contact your local Knorr-Bremse representative. The figurative mark "K" and the trademarks KNORR and KNORR-BREMSE are registered in the name of Knorr-Bremse AG. Additional terms and conditions apply; please refer to our website www.knorr-bremsecvs.com for full Disclaimer. Note: If service work is carried out on a vehicle based on information provided herein, it is the responsibility of the workshop to ensure the vehicle is fully tested and in full functional order before the vehicle is returned into service. Knorr-Bremse accepts no liability for problems caused as a result of appropriate tests not being carried out. Copyright © Knorr-Bremse AG - all rights reserved, including industrial property rights applications. Knorr-Bremse AG retains any power of disposal, such as for copying and transferring. Knorr-Bremse Systeme für Nutzfahrzeuge GmbH · Moosacher Straße 80 · 80809 Munich · Germany · Tel: +49 89 3547-0 · Fax: +49 89 3547-2767 · www.knorr-bremse.com · www.knorr-bremsecvs.com

