

# BENDIX® ETRAC™ AUTOMATED AIR SUSPENSION AXLE LOAD TRANSFER SYSTEM FOR 6X2 SUSPENSIONS

## Weigh Less. Haul More. Keep Moving.

Sometimes you just need some extra traction to get the job done. Whether it's a slippery uphill grade, an inclined loading dock, or anywhere conditions mean your vehicle needs the extra boost to avoid being stuck, the Bendix® eTrac™ automated air bag transfer system for 6x2 suspensions can help.

## Spec Smart. Spec eTrac. Haul More.

Today, fleet operators know how important it is to continue to enhance their bottom line. One good decision can make a big impact. With the Bendix eTrac system, you've made the right choice. With the eTrac system, your fleet can haul up to 450 pounds more freight per vehicle – and more freight means more revenue. That's because now you can spec a 6x2 vehicle with the eTrac system instead of a 6x4 vehicle.

## When Traction Control Engages, So Does eTrac.

Sometimes, in slippery conditions, 6x2 vehicles can't pull away on an inclined ramp or up a hill because of drive wheel spin. Today, the driver must manually push a pneumatically-controlled dash button to transfer air to the driven axle so the vehicle can pull away. But what happens if the driver forgets to disengage the system and begins driving at highway speeds? This mistake – one that happens all too often – can severely damage the driven axle or driveline, meaning vehicle downtime and unexpected maintenance expense. eTrac helps ensure that this won't happen.

The Bendix eTrac system is automatically activated when traction control is active. It is ideal for over the road and long haul fleet operators. Designed for 6x2 tractors and trucks, the eTrac automated air suspension pressure transfer system fully automates what currently is a manual operation. When added to Bendix® Smart ATC™ (automatic traction control), the eTrac system automatically engages and disengages – without driver input – the vehicle's air suspension pressure transfer system during low-traction events. Pressure is transferred from the undriven axle to the driven axle without requiring manual input or driver action.

## How Does It Work?

### Automatic Mode – Typical Operation

When the ATC Mud/Snow switch is OFF, the Bendix eTrac system is in "automatic" mode. This means when ATC becomes active, the eTrac system automatically engages to help the vehicle pull away from a slippery road surface.

When ATC becomes active, the system will transfer air between the air bags on the air suspension until the vehicle exceeds 25 MPH or five (5) seconds after the ATC event has ended. The automatic disengagement feature helps prevent overburdening the driven axle or driveline because the air bag pressure transfer was active for too long.

**Semi-Automatic Mode – When the driver knows it's slippery**  
When the driver activates the ATC Mud/Snow switch, the Bendix eTrac system goes into "semi-automatic" mode and the air bag pressure transfer begins immediately. It automatically disengages when the ATC Mud/Snow switch is turned OFF or when the vehicle speed exceeds 10 MPH.

**Air pressure transfer to the driven axle airbags is automatically limited by the system. This pressure limit is determined by the vehicle OEM at installation and cannot be changed by a fleet.**

### Why a 6x2 might be the right choice for your operation...

- 6x2 axles can offer an average fuel consumption improvement of 2.5% over 6x4 axles.\* For a fleet averaging 8 miles per gallon (mpg), that's almost \$1100 in savings annually per vehicle.\*\*
- Less weight on the truck means more weight for revenue-producing freight. Moving to 6x2 axles from 6x4 axles can mean as much as 450 lbs. in additional cargo carrying capacity.\*
- Save up to \$100/year/per vehicle in maintenance costs with 6x2 axles.\*
- A 6x2 tractor with eTrac technology is a second generation system which means comparable residual values vs. 6x4 tractors.\*
- Automatic deployment maximizes operational uptime: The Bendix eTrac system automatically activates and deactivates without driver input, reducing the need for tire chains.

For a fleet with 500 trucks, switching to a 6x2 axle configuration with eTrac may total as much as \$600,000 in savings per year – not including the potential additional revenue from the ability to carry more payload. What's the bottom line? Depending on your fleet's operational profile, a 6x2 may be the right choice.

*Note: 6x2 axles may not be applicable for all fleet operations or in all regions. Review your operational profile, test equipment, and talk with other fleets before making your decision.*

\*Data used above is from the 2017 6x2 Axle Confidence Report, The North American Council for Freight Efficiency, published July 2017.

\*\*Annual mileage per vehicle of 125,000 miles/year at diesel prices of \$2.88/gallon as of 6/22/18.

The Bendix® eTrac™ technology is a valuable addition to the Bendix® Antilock Braking Systems (ABS) with stability control, providing an additional return on investment and helping to maintain a lower overall total cost of ownership.



# BENDIX® ETRAC™ AUTOMATED AIR SUSPENSION AXLE LOAD TRANSFER SYSTEM FOR 6X2 SUSPENSIONS

## When Is The Bendix eTrac System Right For Your Fleet?

The Bendix® eTrac™ system is available on most wheelbase sizes of select 6x2 tractors with air suspensions equipped with:

- Single leveling valve
- Park brakes on the driven axle only
- J1939 controlled trailer warning lamp
- Bendix® ABS-8 with Smart ATC™ or ESP® (Electronic Stability Program)
  - o Bendix® Premium or Advanced ECU
  - o Bendix® ATC or ESP ECU

By automating the air pressure transfer process, the driven axle and driveline are protected against overburden due to accidental extended driving with the air pressure transferred. This happens all too easily with today's manual push button system.

## We've Got You Covered With After Sale Support and Warranty.

The eTrac system – like all Bendix products – is supported with a network of veteran sales and service professionals, a proven technical support team, and the renowned Bendix Tech Team – an expert technical advice and troubleshooting line dedicated to helping you. Plus, access to expert post-sales support – available 24/7 online, by phone, or in person – is just one part of the Bendix approach that delivers performance, safety, and lower total cost of ownership.



## Air Flow – eTrac Active

### Traction Power From A Simple Yet Effective Vehicle Design

#### A Typical Air Bag Suspension System

- ✓ Protected Reservoir Supply (1)
- ✓ Air Bag Assemblies (2) & (3)
- ✓ Height Control Valve (4)

#### The Additional Bendix® eTrac™ System Components

- ✓ Bendix® FCS-9700™ Fan Clutch Solenoid Valve (5)
- ✓ Bendix® R-12® Relay Valve (6)
- ✓ ABS Controller (7)
- ✓ Backfeed Valve (8)
- ✓ Drive Axle Limiting Valve (9)
- ✓ Double Check Valve (10)

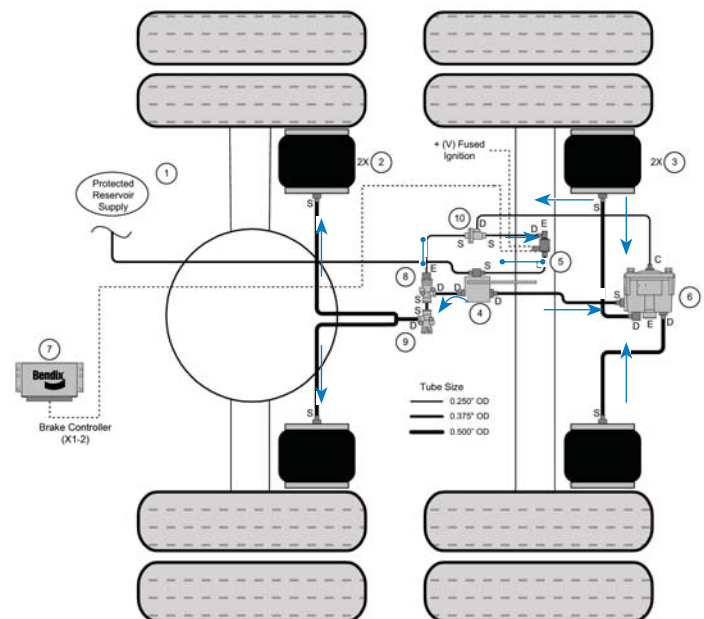

Protect your driveline. Protect your bottom line. Haul more with the Bendix eTrac Automated Air Suspension Axle Load Transfer System for 6x2 Suspensions.

The Bendix eTrac Automated Air Suspension Transfer System for 6x2 Suspensions is available on select Kenworth vehicles. Check with your dealer, call 1-800-AIR-BRAKE (1-800-247-2725), visit [bendix.com](http://bendix.com), or talk to your Bendix Account Manager today.