

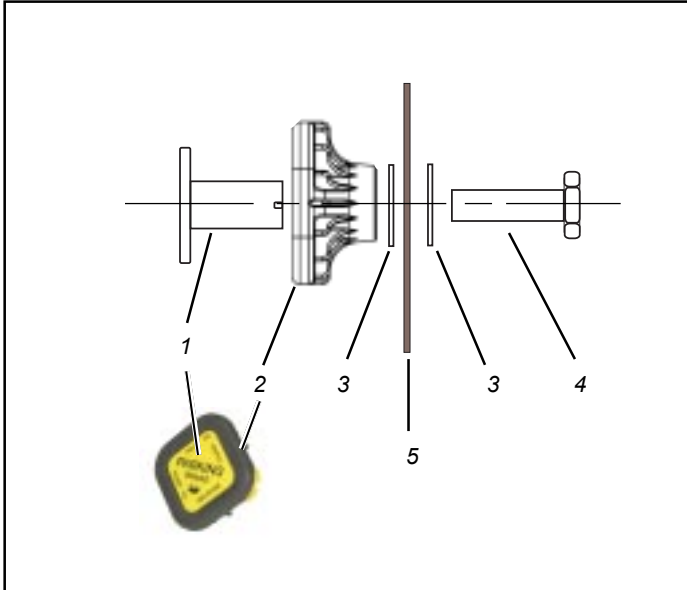

# Installation Instructions

E-Z-Grip™ Button Cover Display Kit  
Piece Number  
5014014

## Bendix® E-Z-Grip™ Display



The E-Z-Grip™ button cover display kit consists of the following:

| Key | Description                                     | Qty |
|-----|---|-----|
| 1   | Button  | 1   |
| 2   | E-Z-Grip™ Button Cover                          | 1   |
| 3   | Washer  | 2   |
| 4   | Bolt  | 1   |
| 5   | Display Stand                                   | 1   |
| 6   | Prepackaged covers (2)<br>(piece number 801526) | 15  |

Figure 1 - E-Z-Grip™ button cover display kit

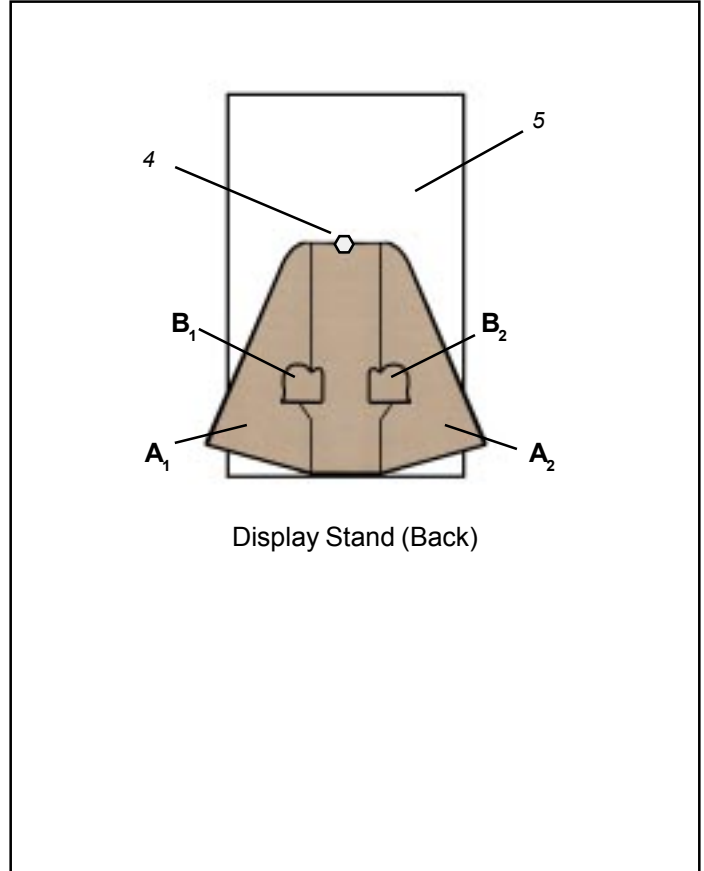

Figure 2 - Display Stand

### Bendix® E-Z-Grip™ Button Cover Display Kit Assembly

Refer to Figure 2.

1. With the display stand(5) turned as shown in figure 2, press and hold lock tab B<sub>1</sub> in place while folding side tab A<sub>1</sub> up until it is perpendicular to the back.
2. Fold lock tab B<sub>1</sub> down until it locks into place on side tab A<sub>1</sub>.
3. Repeat the process for tabs A<sub>2</sub> and B<sub>2</sub>.
4. Place one washer(3) over bolt(4).
5. From the back side insert the bolt(4) with the washer(3) into the hole in the middle of the display stand(5).
6. Slide the second washer(3) over the bolt and attach the button and cover assembly(1&2). Tighten finger tight.
7. The prepackaged button covers(6) are for stocking purposes only.