



Installation Instructions

Bendix® Wingman® FLR10™ to FLR20™ Radar Changeover Kits

PREPARATION

Park the vehicle on level ground. Switch off the ignition and disconnect the battery. See the *General Safety Guidelines*. Read and understand this document before beginning work.

TYPICAL TOOLS REQUIRED

Torx T20 Driver; Wire Cutter; Wire Stripper; Deutsch Crimp Tool HDT-48-00; 13mm Socket and Driver; Wire Brush.

Kit Contents	
Description	Qty
Bendix® FLR20™ Reman Radar	1
Adjusters/Screws.	1
Bracket	1
Harness Adapter	1
Deutsch Connector Mating Kit	1
Upgrade Tag (BW1829)	1

GENERAL SAFETY GUIDELINES



WARNING! PLEASE READ AND FOLLOW THESE INSTRUCTIONS TO AVOID PERSONAL INJURY OR DEATH:



When working on or around a vehicle, the following guidelines should be observed AT ALL TIMES:

- ▲ Park the vehicle on a level surface, apply the parking brakes and always block the wheels. Always wear personal protection equipment.
- ▲ Stop the engine and remove the ignition key when working under or around the vehicle. When working in the engine compartment, the engine should be shut off and the ignition key should be removed. Where circumstances require that the engine be in operation, EXTREME CAUTION should be used to prevent personal injury resulting from contact with moving, rotating, leaking, heated or electrically-charged components.
- ▲ Do not attempt to install, remove, disassemble or assemble a component until you have read, and thoroughly understand, the recommended procedures. Use only the proper tools and observe all precautions pertaining to use of those tools.
- ▲ If the work is being performed on the vehicle's air brake system, or any auxiliary pressurized air systems, make certain to drain the air pressure from all reservoirs before beginning ANY work on the vehicle. If the vehicle is equipped with a Bendix® AD-IS® air dryer system, a Bendix® DRM™ dryer reservoir module, or a Bendix® AD-9si® air dryer, be sure to drain the purge reservoir.
- ▲ Following the vehicle manufacturer's recommended procedures, deactivate the electrical system in a manner that safely removes all electrical power from the vehicle.
- ▲ Never exceed manufacturer's recommended pressures.
- ▲ You should consult the vehicle manufacturer's operating and service manuals, and any related literature, in conjunction with the Guidelines above.
- ▲ Never connect or disconnect a hose or line containing pressure; it may whip and/or cause hazardous airborne dust and dirt particles. Wear eye protection. Slowly open connections with care, and verify that no pressure is present. Never remove a component or plug unless you are certain all system pressure has been depleted.
- ▲ Use only genuine Bendix® brand replacement parts, components and kits. Replacement hardware, tubing, hose, fittings, wiring, etc. must be of equivalent size, type and strength as original equipment and be designed specifically for such applications and systems.
- ▲ Components with stripped threads or damaged parts should be replaced rather than repaired. Do not attempt repairs requiring machining or welding unless specifically stated and approved by the vehicle and component manufacturer.
- ▲ Prior to returning the vehicle to service, make certain all components and systems are restored to their proper operating condition.
- ▲ For vehicles with Automatic Traction Control (ATC), the ATC function must be disabled (ATC indicator lamp should be ON) prior to performing any vehicle maintenance where one or more wheels on a drive axle are lifted off the ground and moving.
- ▲ The power MUST be temporarily disconnected from the radar sensor whenever any tests USING A DYNAMOMETER are conducted on a vehicle equipped with a Bendix® Wingman® system.

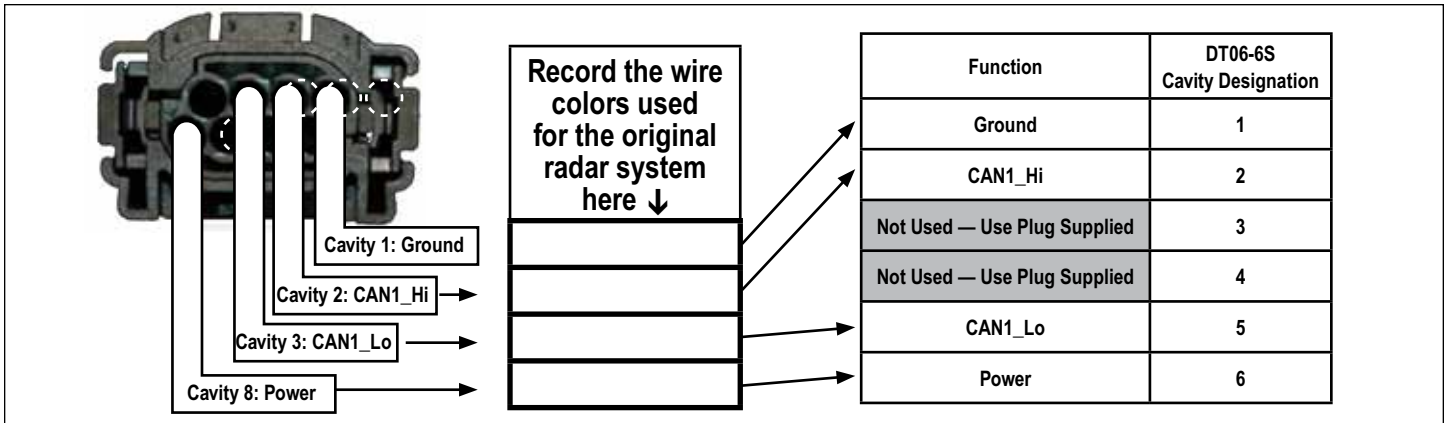

FIGURE 2 - EXISTING WIRE DESIGNATIONS AND THE DT06-6S CAVITIES TO USE IN THE NEW CONNECTOR

Gain access to the radar; where necessary, remove the bumper from the vehicle by following the vehicle manufacturer's instructions.

Remove the Bendix® FLR10™ Radar

1. Disconnect the wire harness from the Bendix® FLR10™ radar. Protect the connector and harness from damage.
2. Typically two (2) bolts are used to attach the bracket to the vehicle. Remove and retain the bolts from the Radar Assembly. (Inspect the bolts; replace corroded/damaged bolts as necessary, using OEM-approved hardware.)
3. Remove the old radar assembly from the bracket and save for core return.

Inspection

4. Inspect and clean all surfaces of the cross-member. Any damage found that would affect the installation of the new radar and bracket should be addressed before continuing with the installation.

Preparing the Harness

5. See Figure 2. Record the wire colors used by the OEM for the locations of the existing speciality vehicle wire harness in the spaces provided in Figure 2
6. Cut the existing wire harness 4 inches, or less, from the connector. After verifying that the wire colors recorded in step 5 above are correct, discard the connector.
7. Carefully review the Deutsch connector manufacturer's instructions for stripping and crimping the wire into the new connector before proceeding.

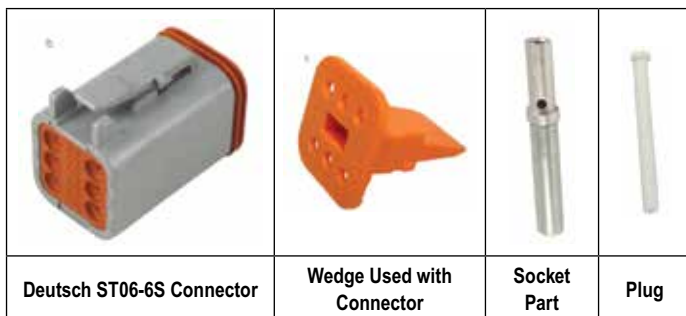

FIGURE 3 - CONNECTOR COMPONENTS

Follow the manufacturer's directions in lieu of the recommendations supplied here:

- (a) Strip all four wires 0.250 to 0.312 inch.
- (b) Crimp the Deutsch socket part [0462-201-16141] on each of the exposed wires. See Figure 4.
- (c) Insert color coded wire/terminal from the truck side (from step 5) into cavity from the rear, following the wiring colors recorded in Step 5. For the two locations not being used, insert the [0413-217-1605] white sealing plugs.

Listen for the audible (and tactile) "click", when the socket seats correctly in the plug.

8. Insert the Deutsch W6S™ locking wedge into the front of the connector. See Figure 3.
9. Plug the assembled connector into the harness adapter supplied.

Prepare the Bendix® FLR20™ Radar and Bracket

10. Insert the three (3) new adjuster assemblies into the bracket.



FIGURE 4 - RADAR SENSOR ADJUSTERS INSTALLATION

11. Insert the six (6) adjuster mounting screws into the assembly. Using a Torx T20 driver, start every screw into the assembly, then tighten them all to 30 in-lbs.

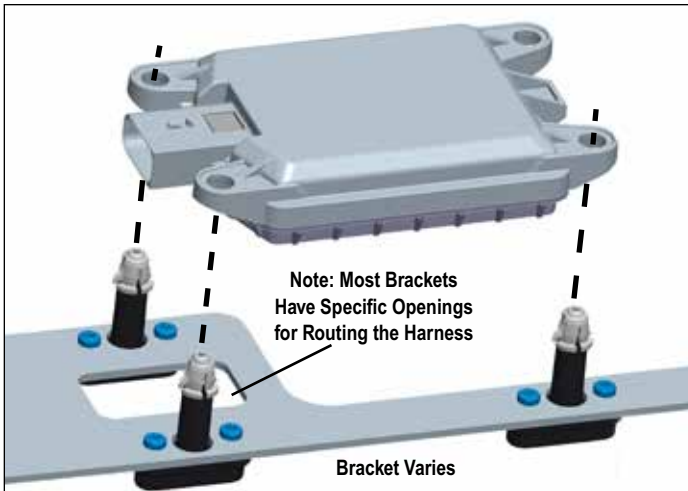

FIGURE 5 - RADAR SENSOR INSTALLATION (EXPLODED VIEW)

12. See Figure 5. With the connector pointing to the passenger side of the vehicle when installed, align the holes in the radar sensor with the adjusters. Install the new radar onto the adjusters by pressing, by hand, with moderate force, on the front surface of the radar. Verify that all three clips at the top of the adjusters have fully engaged into the radar.

Install the Harness

13. Insert the connector into the Bendix® FLR20™ radar.
14. Slide the orange Connector Position Assurance (CPA) tab to the right, making sure the connector is fully engaged.
15. Route the harness through the back of the bracket, firmly securing as necessary.
16. Install the Radar Assembly onto the vehicle by using two (2) bolts removed during disassembly. Torque to vehicle OE specifications.
17. **ALIGN THE RADAR**, per the Appendix on pages 4-6 or refer to *Bendix Service Data Sheet, SD-61-4960*, available for download or order from www.bendix.com.



Remove the steel clip or plate before returning the vehicle to service. When removing stretch-release adhesive strips, be sure to pull directly down on the tab provided and clean any adhesive residue that may be present on the sensor.

18. **For installations where the bracket has a cover**, insert the supplied mounting screws through their respective washers. These are then inserted through the cover and retained by nylon washers on the other side. See Figure 6. Typically the radar will be aligned before the cover is installed.

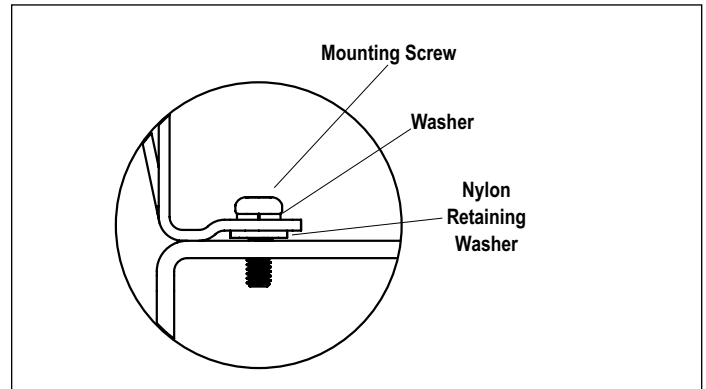

FIGURE 6 - NYLON WASHER INSTALLATION (WHERE NEEDED)

Using a Phillips screwdriver, attach the cover to the bracket using the two screws.

19. Re-install the vehicle's bumper if it was necessary to remove it for this installation, following the OEM's approved practices. Check for radar clearance as shown in the Service Data Sheet. Some bumper modification may be necessary.
20. Return the radar sensor removed from the vehicle, for core return credit using the *Bendix Upgrade Tag (BW1829)* supplied in the kit. The radar must be carefully packaged using suitable materials in a separate container from other core returns.

Bendix Technical Assistance Team

For direct telephone technical support, call the Bendix Tech Team at:

1-800-AIR-BRAKE (1-800-247-2725), option 2. Tech Team members are available Monday through Friday, 8:00 a.m. to 6:00 p.m. ET.

Or, if you prefer, e-mail them at: techteam@bendix.com. Please have the following information ready when you contact the Bendix Tech Team: Bendix product model number; part number and configuration; vehicle make and model.

APPENDIX - RADAR ALIGNMENT USING BENDIX® ALIGNMENT CLIP AND TOOL

Appendix

Bendix® FLR20™ Radar Alignment



A1 LATERAL ALIGNMENT USING THE BENDIX® ALIGNMENT TOOL

This is the method to use for lateral alignment when a radar and/or bracket is replaced.

Tools needed: Bendix alignment kit, steel clip or plate, Torx T-20 screwdriver and a tape measure.

- One of the Bendix Alignment Tools part no: K065284 and K096579—available from Bendix parts outlets—are used. The alignment procedure also requires a steel clip, part number K073087, [or steel plate, (K105222) along with stretch-release adhesive tape].

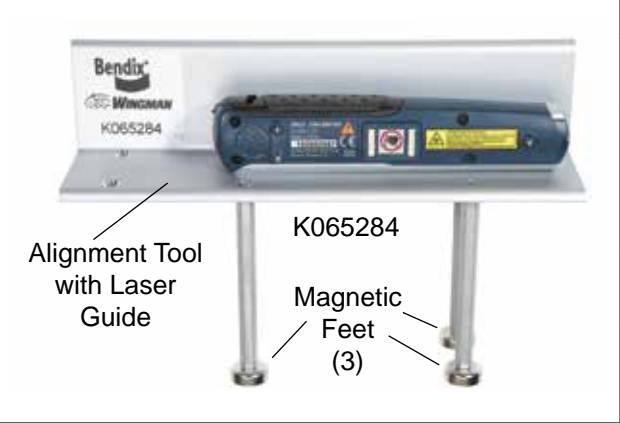
ALIGNMENT TOOLS AVAILABLE

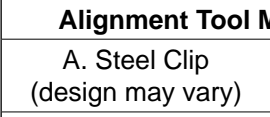
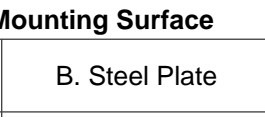
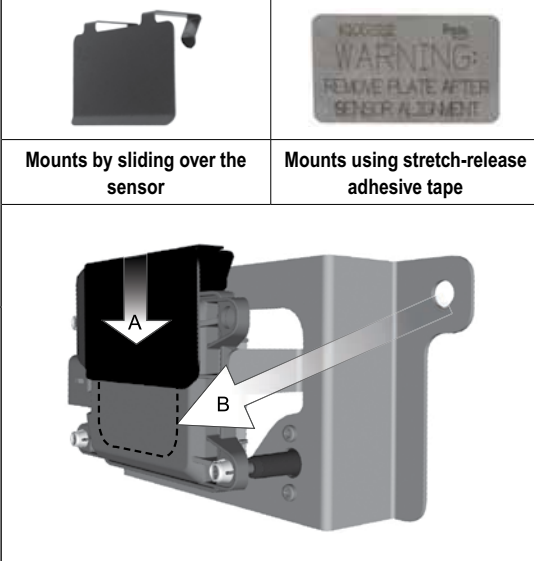
 <p>Alignment Tool with Laser Guide</p> <p>K065284</p> <p>Magnetic Feet (3)</p>	Alignment Tool Mounting Surface	
	A. Steel Clip (design may vary)	B. Steel Plate
 <p>Shorter Bar</p> <p>K096579</p>		
	Mounts by sliding over the sensor	Mounts using stretch-release adhesive tape
		

A1 Park the vehicle on a level floor. Air suspensions must be charged and stable. Install the steel clip by sliding it over the sensor, or install the steel plate to the front of the sensor using stretch-release adhesive tape.

A2 Attach the alignment tool onto the clip or plate using its magnetic feet. Inspect to make sure that the alignment tool is approximately horizontal, width-wise.



A3 Activate the lateral alignment laser light “on” switch. Place the tool into position for the first measurement. (The tool will be reversed when the second measurement is made.)

Appendix

Bendix® FLR20™ Radar Alignment

LATERAL ALIGNMENT USING THE BENDIX® ALIGNMENT TOOL (CONTINUED)

- A4 Locate symmetrical points on the front of the vehicle that are at least 12 inches from the vehicle's center line (such as the tow hooks). Using a ruler or tape measure, record the distance from each side to the laser light line.



LATERAL ALIGNMENT LEFT MEASUREMENT

NOTE: The technician must be careful during the laser positioning process to double-check the values measured on each side of the truck. Be sure to check back and forth for each side of the radar sensor several times to ensure accuracy.

- A5 Repeat the process for the opposite side, reversing the tool, so that the laser light points to the other side of the vehicle.

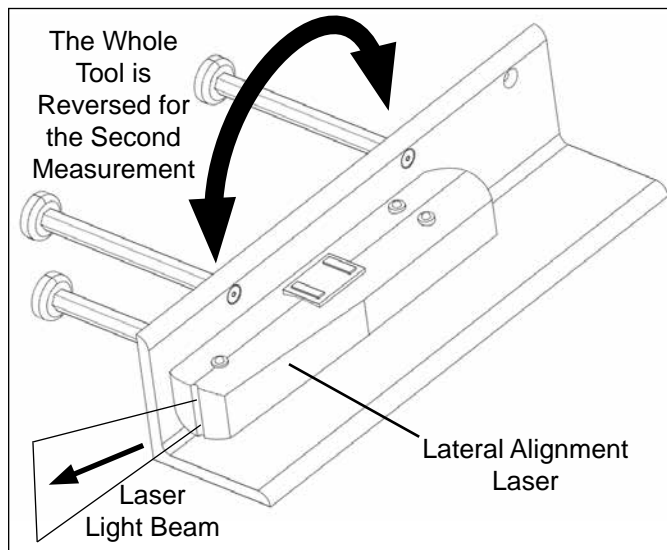

- A6 Compare the left and right distance measurements. A properly aligned radar sensor will have the same measurement from each side. If these two dimensions are within 1/8" (3 mm), no alignment is necessary and the technician can go to Step A10 to check the vertical alignment. If an adjustment is needed, follow the instructions in A7-9.

Appendix

Bendix® FLR20™ Radar Alignment

LATERAL ALIGNMENT USING THE BENDIX® ALIGNMENT TOOL (CONTINUED)

NOTE: Complete these steps only if a lateral adjustment is necessary.

- A7 With the Bendix alignment tool still in place, use the Torx T-20 screwdriver to turn by hand the driver-side stand-off adjustment screw until the desired alignment is reached.

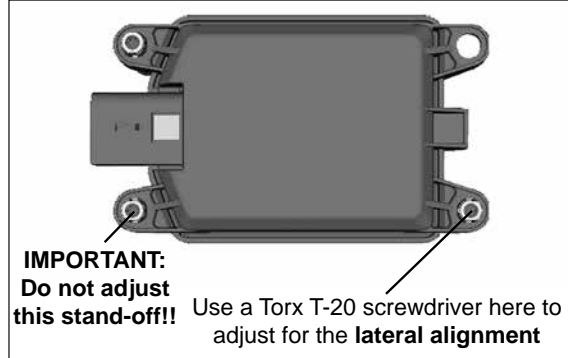

- A8 Re-measure the distances from symmetrical points located at least 12" from the center line of the vehicle. Reverse the tool for each measurement, until the values are the same [within 1/8" (3 mm)].
- A9 After the lateral alignment procedure is complete, if there is an active misalignment DTC (codes 55, 56, or 57), use the instructions in Bendix Service Data Sheet, SD-61-4960 (available from www.bendix.com) to clear the Bendix® Wingman® Advanced™ system's Diagnostic Trouble Code (DTC) using the procedure in Section 4.4: *Clearing Diagnostic Trouble Codes (DTCs)* and reset the alignment value by connecting the vehicle to a PC with Bendix® ACom® Diagnostics software and follow steps B4.4-20 to reset the alignment value. (Also, see Appendix H of the Service Data Sheet.)

- A10 **IMPORTANT: Before returning the vehicle to service, check the vertical alignment.**

- A11 [The steel clip, or plate, and alignment tool should already be in place. See A1-2.]

- A12 Calibrate (or "zero") the inclinometer on a horizontal section of the frame rail. Follow the manufacturer's instructions (typically digital inclinometers have a "SET" button for this purpose).



Calibrate (or "zero") the Digital Inclinometer on a Cab Frame Rail in the direction that the vehicle travels.

Place the calibrated digital inclinometer onto the surface of the tool, **so that the tool is in the same direction as it was on the rail. Verify that the display shows 0° (±1.5°) from vertical.**



NOTE: Complete these steps only if a vertical adjustment is necessary.

- A13 With the Bendix alignment tool still in place, use the screwdriver to turn by hand the top-left adjustment stand-off. See the Figure on the right. During the adjustment, observe the digital display on the inclinometer and turn the vertical alignment screw clockwise or counterclockwise depending on the vertical direction (up or down) needed, until the reading is near zero degrees.

- A14 **The radar is aligned vertically when the display is near zero (0°).**

Note: The alignment process shown here is for Bendix alignment brackets. For other brackets, similar alignment steps will be needed; consult the vehicle manual for full instructions.

Use a Torx T-20 screwdriver here to adjust for the **vertical alignment**



IMPORTANT: Do not adjust this stand-off!!

NOTE: The alignment process is complete after the vertical alignment has been checked (and adjusted, if necessary), and the steel clip or plate is removed. You do not need to test-drive the vehicle.

Appendix

Bendix® FLR20™ Radar Alignment



Remove the steel clip or plate before returning the vehicle to service. When removing the stretch-release adhesive strips, be sure to pull directly down on the tab provided and clean any adhesive residue that may be present on the sensor.

Call the Bendix Tech Team at 1-800-AIR-BRAKE (1-800-247-2725), option 2, for troubleshooting assistance.



Log-on and Learn from the Best

On-line training that's available when you are –24/7/365.
Visit www.brake-school.com.