

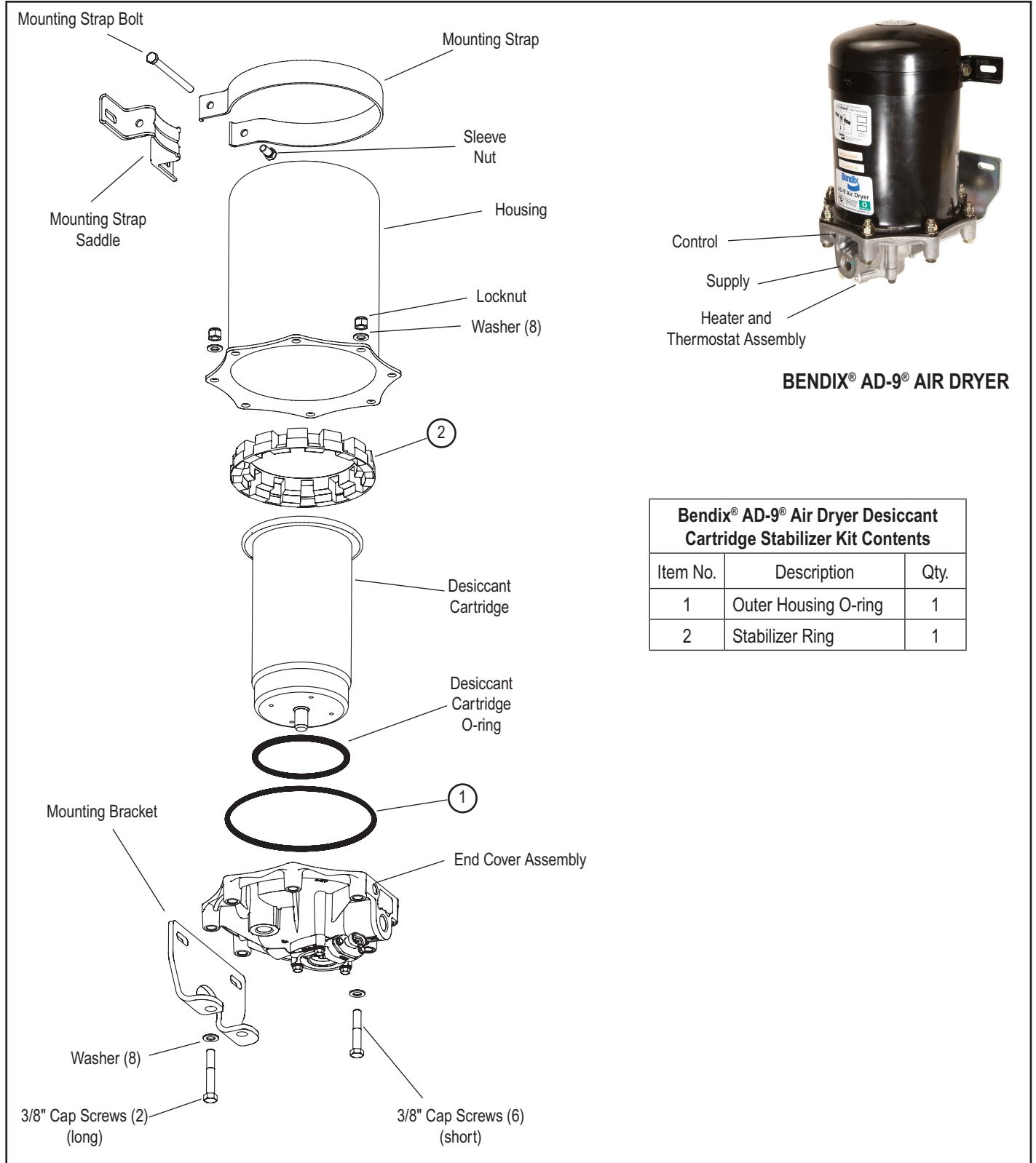

Installation Instructions

BENDIX® AD-9® AIR DRYER CARTRIDGE STABILIZER KIT



BENDIX® AD-9® AIR DRYER

Bendix® AD-9® Air Dryer Desiccant Cartridge Stabilizer Kit Contents		
Item No.	Description	Qty.
1	Outer Housing O-ring	1
2	Stabilizer Ring	1

Figure 1 Bendix® AD-9® Air Dryer Exploded View and Kit Contents

GENERAL SAFETY GUIDELINES

WARNING!

PLEASE READ AND FOLLOW THESE INSTRUCTIONS TO AVOID PERSONAL INJURY OR DEATH:

When working on or around a vehicle, the following general precautions should be observed at all times.

1. Park the vehicle on a level surface, apply the parking brakes, and always block the wheels. Always wear safety glasses.
2. Stop the engine and remove ignition key when working under or around the vehicle. When working in the engine compartment, the engine should be shut off and the ignition key should be removed. Where circumstances require that the engine be in operation, **EXTREME CAUTION** should be used to prevent personal injury resulting from contact with moving, rotating, leaking, heated or electrically charged components.
3. Do not attempt to install, remove, disassemble or assemble a component until you have read and thoroughly understand the recommended procedures. Use only the proper tools and observe all precautions pertaining to use of those tools.
4. If the work is being performed on the vehicle's air brake system, or any auxiliary pressurized air systems, make certain to drain the air pressure from all reservoirs before beginning **ANY** work on the vehicle. If the vehicle is equipped with a Bendix® AD-IS® air dryer system or a dryer reservoir module, be sure to drain the purge reservoir.
5. Following the vehicle manufacturer's recommended procedures, deactivate the electrical system in a manner that safely removes all electrical power from the vehicle.
6. Never exceed manufacturer's recommended pressures.
7. Never connect or disconnect a hose or line containing pressure; it may whip. Never remove a component or plug unless you are certain all system pressure has been depleted.
8. Use only genuine Bendix® brand replacement parts, components and kits. Replacement hardware, tubing, hose, fittings, etc. must be of equivalent size, type and strength as original equipment and be designed specifically for such applications and systems.
9. Components with stripped threads or damaged parts should be replaced rather than repaired. Do not attempt repairs requiring machining or welding unless specifically stated and approved by the vehicle and component manufacturer.
10. Prior to returning the vehicle to service, make certain all components and systems are restored to their proper operating condition.
11. For vehicles with Automatic Traction Control (ATC), the ATC function must be disabled (ATC indicator lamp should be ON) prior to performing any vehicle maintenance where one or more wheels on a drive axle are lifted off the ground and moving.

This kit is intended for replacing the desiccant cartridge stabilizer ring on some Bendix® AD-9® and AD-9® PuraGuard® oil coalescing air dryers.

CLEANING AND INSPECTION

1. Using mineral spirits or an equivalent solvent, clean and dry the outside of the air dryer.
2. When servicing, inspect the interior and exterior of all metal parts for severe corrosion, pitting and cracks. If this condition exists, replace the air dryer. Superficial corrosion, and/or pitting on the exterior portion of the upper and lower body halves, is acceptable.
3. Inspect all air line fittings for corrosion. Repair or replace any leaking or damaged lines or fittings. Clean all old thread sealant from the pipe threads.

WARNING: For dryers originally equipped with a stabilizer ring (2), the stabilizer ring **MUST** be reused or replaced (Refer to Figure 3). Failure to replace the stabilizer ring may result in premature metal fatigue of the desiccant cartridge in the area of the center bolt. Metal fatigue of the desiccant cartridge may result in desiccant entering the air brake system.

IMPORTANT: When installing this kit, it is recommended to remove the AD-9 air dryer from the vehicle.

BENDIX® AD-9® AIR DRYER REMOVAL

1. Park the vehicle on a level surface and prevent movement by means other than the brakes.
2. Drain all reservoirs to 0 psi **Caution:** The compressor discharge line may still contain residual pressure.
3. Identify and disconnect the three air lines from the end cover and note the position of end cover ports relative to the vehicle.

4. Unplug the vehicle wiring harness connector from the heater and thermostat assembly connector on the end cover assembly. *Refer to Figure 5.*
5. Loosen the 5/16" X 4-1/2" mounting strap bolt securing the upper mounting strap.
6. Remove, retain and mark the two 3/8" end cover cap screws, locknuts and washers that retain the lower mounting bracket to the end cover, also mark these two holes of the end cover. (These bolts are longer than the other six bolts.)
7. Remove the AD-9 air dryer from its mounting brackets on the vehicle.

DISASSEMBLY (Refer to Figure 1.)

Caution: While performing service on the Bendix AD-9 air dryer, it is not recommended that a clamping device (vise, C-clamp, etc.) be used to hold any die cast aluminum component, as damage may result. To hold the end cover, install a pipe nipple in the supply port and clamp the nipple in a vise.

1. Remove the remaining six 3/8" cap screws, locknuts, and the twelve washers that secure the end cover to the outer housing. Separate the end cover from the outer housing. Note: Some AD-9 air dryers have a stabilizer ring (2) on top of the cartridge. Set all components aside.
2. Remove and discard the outer housing o-ring(1).
3. Remove and discard the desiccant cartridge stabilizer ring (2), if present. *Refer to Figure 3.*

ASSEMBLY (Refer to Figure 1.)

1. Install the outer housing o-ring (1) on the shoulder in the end cover.
2. Place the desiccant cartridge stabilizer ring (2) on top of the air dryer cartridge. See Figure 3.

NOTE: Bendix® AD-9® remanufactured desiccant cartridges come in two different heights, varying 3/4". (Although the cartridges vary in height, their functionality and performance is the same.) The stabilizer ring (2) can only be used with the shorter, most common cartridge.

If installing this kit as well as a remanufactured desiccant cartridge kit, compare the removed cartridge to the cartridge in the kit. If the cartridge in the kit is taller, it should be exchanged for a shorter unit.

If the air dryer being serviced did not previously have a stabilizer ring (2) installed, and a stabilizer ring is being added for the first time, it is possible that the installed cartridge could be a taller cartridge, and the stabilizer ring may not fit. To verify the size, place the stabilizer ring on an existing cartridge and slip the air dryer housing over the cartridge. If the housing rests on the stabilizer ring, but doesn't reach the top surface of the end cover to permit fastening, then the cartridge must be replaced with a shorter cartridge before the stabilizer ring can be installed. Note that operating certain vehicles without the stabilizer ring can cause premature air dryer damage.

3. With the outer housing over the desiccant cartridge and stabilizer ring (2), align the holes in the housing with those in the end cover.
4. Install the six 3/8" cap screws, the locknuts and the twelve washers, making certain they are in the proper position as marked during disassembly. The two longer 3/8" cap screws will be used to secure the AD-9 air dryer to its mounting bracket. Tighten the six cap screws and locknuts in a star pattern (Refer to Figure 2). Torque to 270–385 in-lbs. Note: The two remaining bolt holes in the end cover and two 3/8" cap screws must be the ones marked during disassembly to assure proper orientation of the ports and adequate length of the cap screws.

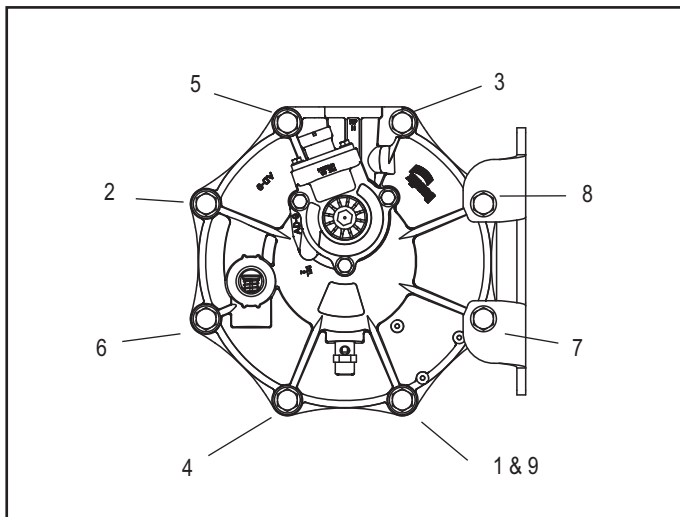

Figure 2 End Cover Bolt Torque Pattern



Figure 3 AD-9 Air Dryer Cartridge Stabilizer Ring

INSTALLATION

1. Install the assembled Bendix AD-9 air dryer back onto the vehicle by slipping it into the mounting strap and saddle. Align the two unused holes in the end cover with the bottom mounting bracket so that the bottom of bracket supports the air dryer. The air dryer end cover should rest on the bracket. Using the remaining two 3/8" cap screws (long), four washers and two locknuts, secure the air dryer to the lower bracket. Tighten, then torque the two remaining cap screws to 270–385 in-lbs.
2. Tighten the 5/16" X 4-1/2" bolt and nut on the upper mounting strap and saddle. Torque to 80–120 in-lbs.
3. Re-connect the three air lines to the proper ports on the end cover assembly (identified during disassembly).
4. Re-connect the vehicle wiring harness connector to the AD-9 air dryer heater and thermostat assembly connector by plugging it into the air dryer connector until the lock tab snaps in place. See Figure 5.
5. Before placing vehicle back into service, perform the Operation and Leakage Tests contained in this instruction sheet.

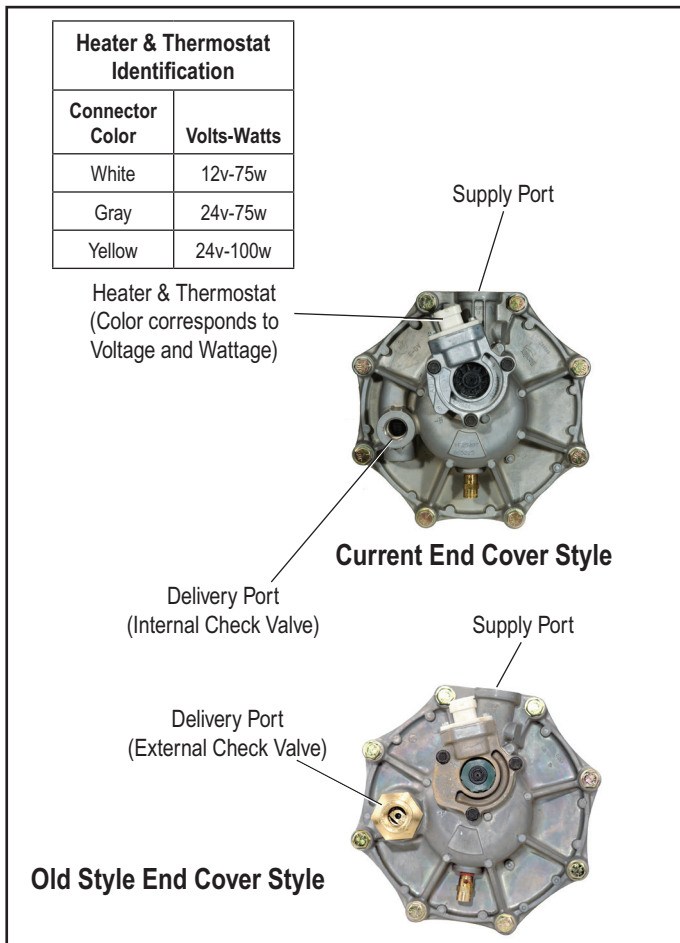

Figure 4 Bendix® AD-9® Air Dryer End Covers

OPERATION AND LEAKAGE TESTS (Refer to Figure 4.)

1. Test the outlet port check valve by building the air system to governor cut-out and observing a test air gauge installed in the #1 reservoir. Check all lines and fittings leading to and from the air dryer for leakage and integrity. A rapid loss of pressure could indicate a failed outlet check valve. To confirm, identify the check valve type and follow the test procedure.

Old style end cover with brass check valve: Bleed the system down, remove the check valve assembly from the end cover, and then bench test by applying air pressure to the check valve and applying a soap solution to the other end. Leakage should not exceed a one inch bubble in one second.

New style end cover with integrated outlet check valve: Test by applying air pressure to the delivery port and applying a soap solution to the end cover all around the port. Leakage should not exceed a one inch bubble in one second.

2. Check for excessive leakage of the purge valve. With the compressor loaded (compressing air), apply a soap solution to the purge valve housing assembly exhaust port and observe that leakage does not exceed a one inch bubble in one second. If the leakage exceeds the maximum specified, service the purge valve housing assembly.

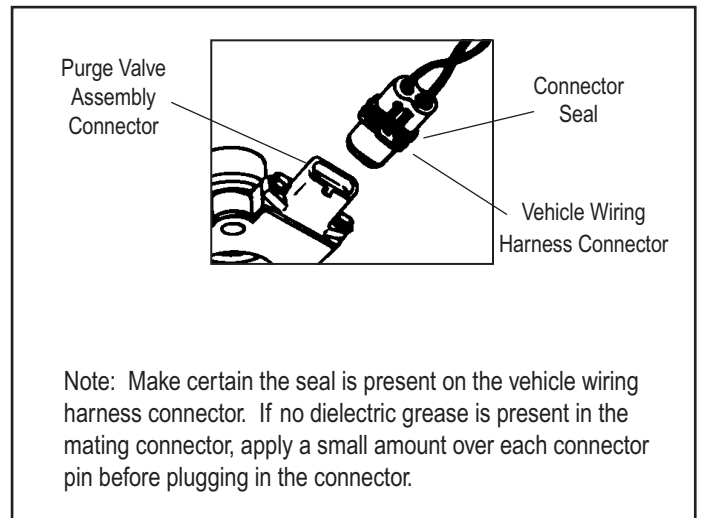

Figure 5 Wiring Harness Connectors

3. Close all reservoir drain cocks. Build up system pressure to governor cut-out and note that Bendix® AD-9® air dryer purges with an audible escape of air. "Fan" the service brakes to reduce system air pressure to governor cut-in. Note that the system once again builds to full pressure and is followed by an air dryer purge.
4. Check the operation of the safety valve by pulling the exposed stem while the compressor is loaded (compressing air). There must be an exhaust of air while the stem is held and the valve should re-seat when the stem is released.
5. Check the operation of the end cover heater and thermostat assembly during cold weather operation as follows:

A. Electric Power to the Dryer (Refer to Figure 5)

With the ignition or engine kill switch in the ON position, check for voltage to the Heater and Thermostat assembly using a voltmeter or test light. Unplug the electrical connector at the air dryer and place the test leads on each of the pins of the male connector. If there is no voltage, look for a blown fuse, broken wires, or corrosion in the vehicle wiring harness. Check to see if a good ground path exists.

B. Thermostat and Heater Operation.

Turn off the ignition switch and cool the end cover assembly to below 40° Fahrenheit. Using an ohmmeter, check the resistance between the electrical pins in the female connector. The resistance should be between 1.0 and 3.0 ohms for the 12 volt heater assembly and 4.8 to 9.0 ohms for the 24 volt heater assembly. If the resistance is higher than the maximum stated, replace the heater and thermostat assembly.

Warm the end cover assembly to over 90° Fahrenheit and again check the resistance. The resistance should exceed 1000 ohms. If the resistance values obtained are within the stated limits, the thermostat and heater is operating properly. If the resistance values obtained are outside the stated limits, replace the Heater and Thermostat assembly.