

UP2DATE

KNORR-BREMSE CLUTCH COMPRESSOR FOR MAN APPLICATIONS

Compressors from Knorr-Bremse are installed on several types of commercial vehicles, producing compressed air for braking and suspension systems. In 2010 Knorr-Bremse launched a Clutch Compressor for MAN applications which is now also available for the Independent Aftermarket.

Knorr-Bremse was the first manufacturer to launch the Clutch Compressor to the European market. Unlike compressors using conventional technology, clutch compressors avoid idle running phases. Instead, there are standby periods during which the engine output is physically separated from the compressor, thereby saving energy and reducing compressor wear.

The Knorr-Bremse Clutch Compressor convinces by the following benefits:

- Reduction of a truck's CO2 emissions by up to 2.5 tonnes per year
- Average reduction of diesel fuel consumption by up to 1,000 litres per year for a long haul vehicle
- Reduced oil carry-over
- Increased compressor lifetime

Key Facts Clutch Compressor MAN

- › Single cylinder design 360cc
- › Operating pressure up to 12,5 bar
- › Water-cooled cylinder head
- › Pneumatically operated clutch

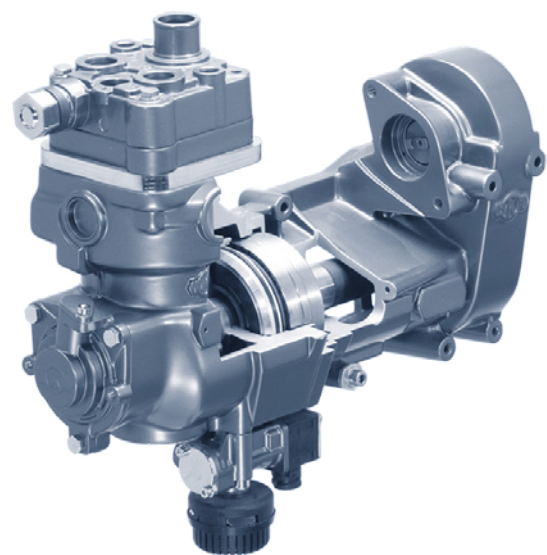

OVERVIEW OF COMPRESSORS AND SERVICE KITS

Please see the tables below for an overview of compressor part numbers and corresponding service kits.

Compressor Part Numbers

Knorr-Bremse IAM P/N		Knorr-Bremse OE P/N		MAN P/N	
New P/N	Replaces P/N	New P/N	Replaces P/N	New P/N	Replaces P/N
K118690N00	K082266N00	K118690N04	K035435N04	51.54000-7147	51.54000-7144
			K071325N04		51.54000-7145
			K082266N04		54.54000-7146

€  A core return surcharge will apply.

In order to ensure the highest quality and an optimal service, Knorr-Bremse has developed a specific service concept for the MAN Clutch Compressor. The workshop-proven service kits combine all necessary components needed for specific service actions including the latest technical improvements and revisions.

Service Kit Part Numbers

Compressor Module	Knorr-Bremse IAM P/N
Complete Compressor Unit	K052041K50
Piston Kit	K061052K50
Valve Plate Kit	K105788K50
Cylinder Head Kit (5th screw cylinder head)	K105789K50
Cylinder Head Kit (change over kit to 5th screw, incl. valve plate assembly)	K114439K50
Safety Valve Kit	K081929K50
Clutch Module	
Clutch Housing Kit	K052056K50
Clutch Shaft Kit (without housing)	K108151K50
Gear Kit	K108148K50
Clutch Kit	K097453K50
Pressure Switch / Solenoid Valve	
Pressure Switch Kit	K028391K50
Silencer Kit	K034195
Clutch Control Valve (solenoid)	K081973K50
Gasket / Seals	
General Service Kit (all gaskets)	K052058K50
O-Ring Kit	K164364K50

Note: The "MAN P/N" should only be used as a reference for the identification of the relevant IAM part numbers. The information is supplied without liability.

For a safe and optimal service of the clutch, Knorr-Bremse offers a specifically designed Clutch Compressor tool case. Please refer to the corresponding Up2date Y282362 for further details.

EVERY VEHICLE TELLS ITS STORY.
KEEP IT RUNNING

Up-to-date information on our products can be
found on our website www.knorr-bremsecvs.com



Knorr-Bremse Group

Knorr-Bremse Systems for Commercial Vehicles

Moosacher Strasse 80 | 80809 Munich | Germany
Tel: +49 89 3547-0 | Fax: +49 89 3547-2767
WWW.KNORR-BREMSECVS.COM

Note

All information is subject to change. A printed version of this document may therefore not correspond to the latest revision. To obtain the latest version, please visit our website www.knorr-bremsecvs.com or contact a Knorr-Bremse representative in your area.

If service work is carried out on a vehicle based on information provided herein, it is the responsibility of the workshop to ensure the vehicle is fully tested and in full functional order before the vehicle is returned into service. Knorr-Bremse accepts no liability for problems caused as a result of appropriate tests not being carried out.

Copyright © Knorr-Bremse AG

All rights reserved, including industrial property rights applications. Knorr-Bremse AG retains any power of disposal, such as for copying and transferring.

Disclaimer

The information contained herein is intended for the exclusive use of trained persons within the commercial vehicle industry, and must not be passed on to any third party. All recommendations regarding products and their servicing or usage are with reference to Knorr-Bremse products and should not be considered applicable to products from other manufacturers. This information does not purport to be all-inclusive and no responsibility is assumed as a result of its use. We cannot accept any liability nor offer any guarantee regarding data accuracy, completeness or timeliness. The information does not represent any guarantee or ensured characteristics of the Products or Systems described. No liability can be accepted based on the information, its use, recommendations or advice provided. In no event may we be held liable for any damage or loss except in the case of wilful intent or gross negligence on our part, or if any mandatory legal provisions apply. This disclaimer is an English translation of a German text, which should be referred to for all legal purposes. Any legal disputes arising from the use of this information shall be subject to German law.