



Installation Instructions

Replace Bendix® AR-1DC™ Antilock Relay Valve with Bendix® R-12DC® Relay Valve

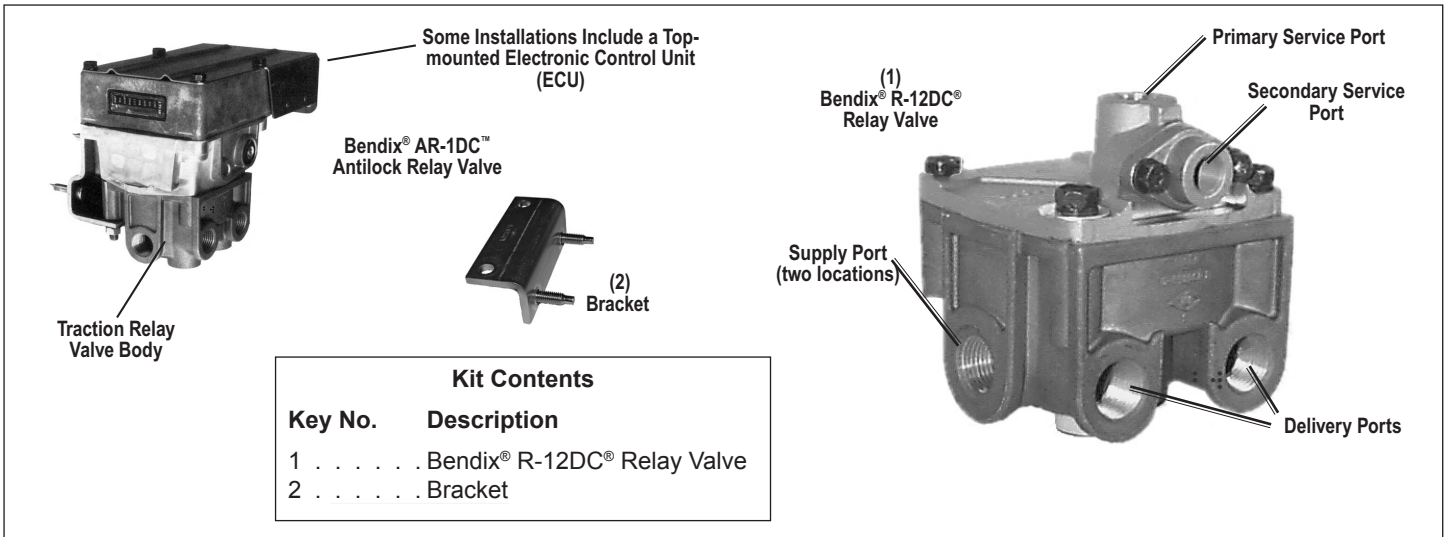

FIGURE 1 - BENDIX® AR-1DC™ ANTILOCK RELAY VALVE REPLACEMENT KIT

VEHICLE PREPARATION

Follow all standard industry safety precautions – including, but not limited to – those listed on page 2 of these instructions.

1. Park the vehicle on a level surface and block the wheels and/or hold the vehicle by means other than the air brakes.
2. Drain the air pressure from all vehicle reservoirs.

REMOVAL

1. Prior to disassembly, remove as much contamination as possible from the exterior of the device.
2. Identify and mark, or label, the electrical wiring harness and air hoses and their respective connections on the valve to aid the technician during reinstallation.
3. Disconnect the air hoses from the AR-1DC™ antilock relay valve.
4. Disconnect the electrical connections.
5. Remove the mounting hardware bolts and then remove the Electronic Control Unit (ECU) from the valve, if so equipped. (See Figure 1.) Retain the hardware for reinstallation.
6. Discard the original relay valve body.

INSPECTION

Inspect the mounting location for deterioration, wear, and corrosion. Replace and/or repair as necessary.

INSTALLATION

See Figure 2. Use the schematic diagrams shown as you plan the location(s) to install the replacement components. Take into consideration the routing of the electrical

harnesses, hoses and orientation of the replacement valves, and the remote mounting of the ECU controller (if required). Note: All torques specified in this document are assembly torques and can be expected to fall off slightly after assembly. Do not re-torque after initial assembly torques fall off. For assembly, **use hand tools or torque limited drivers. Do not use an impact driver to install any fittings.** Use a professional grade thread sealant on all air line connections to the valves.

INSTALLATION: BENDIX® R-12DC® RELAY VALVE

1. In most cases, the bracket supplied in the kit will allow the existing holes in the frame rail to be used. (See Figure 1.)
2. Inspect the location where the valve is to be installed. Drill holes as necessary for the supplied mounting bracket or, if necessary, to re-use the original bracket(s). Wherever possible, select a location that allows the original hoses, harnesses etc. to be re-used. The steps that follow assume that the technician is able to use the supplied bracket for this installation.
3. See Figure 1. Two fasteners in the cover of the relay valve will need to be removed to permit the installation of the bracket. Note: One of the four fasteners will typically have an I.D. washer to show the crack pressure. (Be sure to re-use the I.D. washer.)
4. Attach the Mounting Bracket (2), re-using the fasteners with locking nuts or lockwashers; torque to 120-160 in-lbs.
5. Mount the assembly to the vehicle using a torque of 200-240 in-lbs.

GENERAL SAFETY GUIDELINES

WARNING! PLEASE READ AND FOLLOW THESE INSTRUCTIONS TO AVOID PERSONAL INJURY OR DEATH:

When working on or around a vehicle, the following general precautions should be observed **at all times**.

1. Park the vehicle on a level surface, apply the parking brakes, and always block the wheels. Always wear safety glasses.
2. Stop the engine and remove ignition key when working under or around the vehicle. When working in the engine compartment, the engine should be shut off and the ignition key should be removed. Where circumstances require that the engine be in operation, **EXTREME CAUTION** should be used to prevent personal injury resulting from contact with moving, rotating, leaking, heated or electrically charged components.
3. Do not attempt to install, remove, disassemble or assemble a component until you have read and thoroughly understand the recommended procedures. Use only the proper tools and observe all precautions pertaining to use of those tools.
4. If the work is being performed on the vehicle's air brake system, or any auxiliary pressurized air systems, make certain to drain the air pressure from all reservoirs before beginning ANY work on the vehicle. If the vehicle is equipped with a Bendix® AD-IS® air dryer system or a dryer

reservoir module, be sure to drain the purge reservoir.

5. Following the vehicle manufacturer's recommended procedures, deactivate the electrical system in a manner that safely removes all electrical power from the vehicle.
6. Never exceed manufacturer's recommended pressures.
7. Never connect or disconnect a hose or line containing pressure; it may whip. Never remove a component or plug unless you are certain all system pressure has been depleted.
8. Use only genuine Bendix® brand replacement parts, components and kits. Replacement hardware, tubing, hose, fittings, etc. must be of equivalent size, type and strength as original equipment and be designed specifically for such applications and systems.
9. Components with stripped threads or damaged parts should be replaced rather than repaired. Do not attempt repairs requiring machining or welding unless specifically stated and approved by the vehicle and component manufacturer.
10. Prior to returning the vehicle to service, make certain all components and systems are restored to their proper operating condition.
11. For vehicles with Automatic Traction Control (ATC), the ATC function must be disabled (ATC indicator lamp should be ON) prior to performing any vehicle maintenance where one or more wheels on a drive axle are lifted off the ground and moving.

6. Connect the air hoses to the valve, using the labels applied, to assist in identification.
7. Where applicable, remote mount the ECU removed from the original valve assembly using the mounting hardware retained during disassembly.
8. Connect the ECU to the vehicle harness. Secure harnesses with tie-wraps as needed.
9. Test the valve as outlined in the *Operational and Leakage Tests* section before returning the vehicle to service.

GENERAL

Always check the vehicle brake system for proper operation after performing brake work and before returning the vehicle to service.

OPERATIONAL AND LEAKAGE TESTS

1. Chock the wheels, and fully charge the air brake system.

OPERATION TEST

1. Apply and release the brakes several times and check for prompt application and release at each wheel.

If an incomplete or sluggish release of the brakes is noted at some, but not all wheels, test the Antilock Modulator Valve(s) operating those wheels for proper operation, and inspect for kinked or obstructed air hose leading to, or from, the Modulator(s).

If an incomplete or sluggish release is noted at all wheels, inspect for kinked or obstructed air hoses leading to, or from, the relay valve.

Refer to the Bendix® R-12DC® Relay Valve Service Data sheet (SD-03-1068) for additional troubleshooting information.

LEAKAGE TESTS

1. With the air system pressure charged to governor cutout, apply a soap solution to the relay valve exhaust port. The leakage noted should not exceed a one-inch bubble in 3 seconds.
2. Make and hold a full brake application and apply a soap solution to the exhaust port and around the cover where it joins the body. The leakage noted should not exceed a one-inch bubble in 3 seconds at the exhaust port.

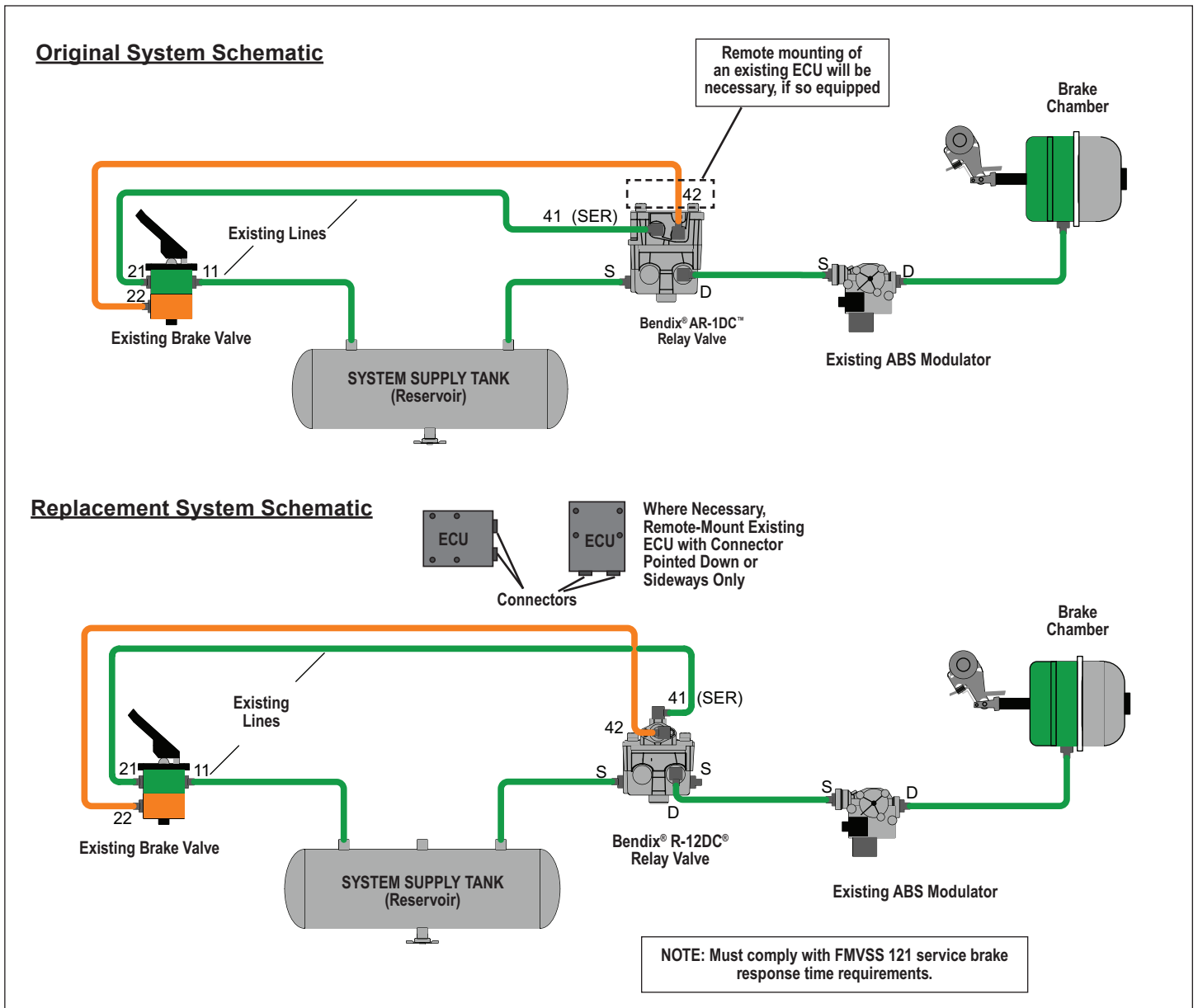

FIGURE 2 - SYSTEM SCHEMATICS

3. Check for inlet valve and O-ring leakage. Make this check with the service brakes released. Coat the exhaust port and the area around the retaining ring with a soap solution; leakage of a one-inch bubble in 3 seconds is permitted.



Bendix Technical Assistance Team

For direct telephone technical support, call the Bendix Tech Team at: 1-800-AIR-BRAKE (1-800-247-2725). Tech Team members are available Monday through Friday, 8:00 A.M. to 6:00 P.M. EST.

Or, if you prefer, e-mail us at: techteam@bendix.com. Please have the following information ready when you contact the Bendix Tech Team: Bendix product model number; part number and configuration; vehicle make and model; and vehicle configuration (number of axles, tire size, etc.).

Reference:

The full range of Service Data sheets for the Bendix® valves used in this kit are available for download at the Document Library on www.bendix.com. You can also order copies from the Literature Center at the website.