



# Installation Instructions

Replace Bendix® ATR-1DC™ Traction Relay Valve with Bendix® R-12DC® Relay Valve and AT-3™ Traction Valve

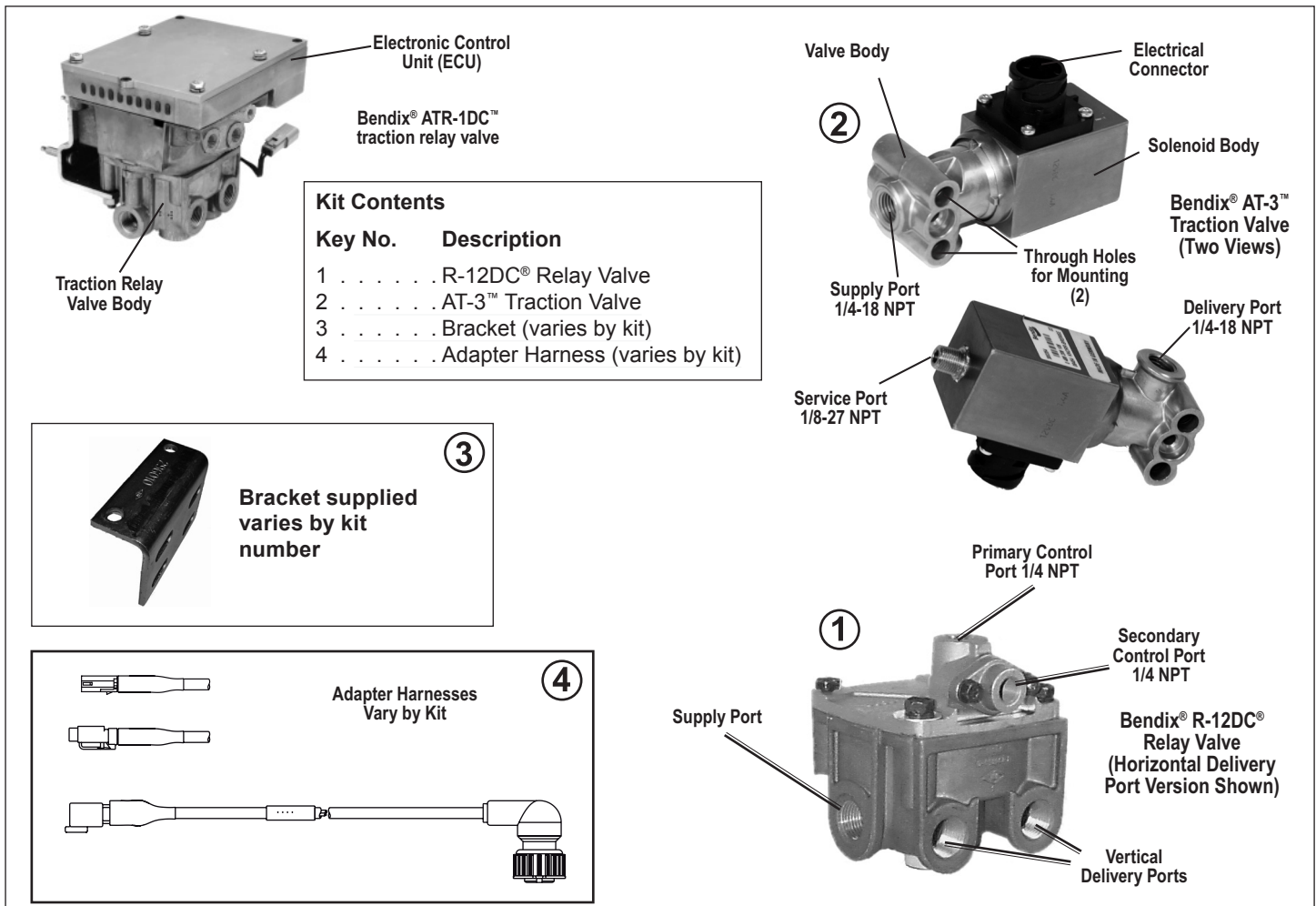

FIGURE 1 - BENDIX® ATR-6™ TRACTION RELAY VALVE (WITH EXPLODED VIEW)

## VEHICLE PREPARATION

Follow all standard industry safety precautions, including, but not limited to, those listed on page two of these instructions.

1. Park the vehicle on a level surface and block the wheels and/or hold the vehicle by means other than the air brakes.
2. Drain the air pressure from all vehicle reservoirs.

## REMOVAL

1. Prior to disassembly, remove as much contamination as possible from the exterior of the device.
2. Identify and mark or label the electrical wiring harness and air hoses and their respective connections on the valve to aid the technician during reinstallation.
3. Disconnect air hoses from the Bendix® ATR-1DC™ traction relay valve.
4. Disconnect the electrical connections.
5. Remove the mounting hardware bolts and then remove the Electronic Control Unit (ECU) from the valve. (See Figure 1).

6. Discard the original traction control valve body.

## INSPECTION

1. Inspect the mounting location for deterioration, wear, and corrosion. Replace and/or repair as necessary.

## INSTALLATION

See the schematic diagrams on page 3 as you plan the locations to install the replacement components. Take into consideration the routing of the electrical harnesses, hoses and orientation of the replacement valves and the remote mounting of the ECU controller. Note that the schematics show the new air lines (some indicated as 3/8 inch) that will be required for this repair.

Note: All torques specified in this document are assembly torques and can be expected to fall off slightly after assembly. Do not re-torque after initial assembly torques fall. For assembly, **use hand tools or torque limited drivers. Do not use impact driver to install any fittings.** Use a professional grade thread sealant on all air lines connections to the valves.

## GENERAL SAFETY GUIDELINES

### WARNING! PLEASE READ AND FOLLOW THESE INSTRUCTIONS TO AVOID PERSONAL INJURY OR DEATH:

When working on or around a vehicle, the following general precautions should be observed at all times.

1. Park the vehicle on a level surface, apply the parking brakes, and always block the wheels. Always wear safety glasses.
2. Stop the engine and remove ignition key when working under or around the vehicle. When working in the engine compartment, the engine should be shut off and the ignition key should be removed. Where circumstances require that the engine be in operation, **EXTREME CAUTION** should be used to prevent personal injury resulting from contact with moving, rotating, leaking, heated or electrically charged components.
3. Do not attempt to install, remove, disassemble or assemble a component until you have read and thoroughly understand the recommended procedures. Use only the proper tools and observe all precautions pertaining to use of those tools.
4. If the work is being performed on the vehicle's air brake system, or any auxiliary pressurized air systems, make certain to drain the air pressure from all reservoirs before beginning ANY work on the vehicle. If the vehicle is equipped with an AD-IS® air dryer system or a dryer reservoir module, be sure to drain the purge reservoir.
5. Following the vehicle manufacturer's recommended procedures, deactivate the electrical system in a manner that safely removes all electrical power from the vehicle.
6. Never exceed manufacturer's recommended pressures.
7. Never connect or disconnect a hose or line containing pressure; it may whip. Never remove a component or plug unless you are certain all system pressure has been depleted.
8. Use only genuine Bendix® brand replacement parts, components and kits. Replacement hardware, tubing, hose, fittings, etc. must be of equivalent size, type and strength as original equipment and be designed specifically for such applications and systems.
9. Components with stripped threads or damaged parts should be replaced rather than repaired. Do not attempt repairs requiring machining or welding unless specifically stated and approved by the vehicle and component manufacturer.
10. Prior to returning the vehicle to service, make certain all components and systems are restored to their proper operating condition.
11. For vehicles with Automatic Traction Control (ATC), the ATC function must be disabled (ATC indicator lamp should be ON) prior to performing any vehicle maintenance where one or more wheels on a drive axle are lifted off the ground and moving.

## INSTALLATION OF BENDIX® AT-3™ TRACTION VALVE

Bendix approves two methods of installation:

- (a) either install the valve onto the vehicle with OEM approved mounting bolts, and then attach the fittings, or,
  - (b) bench installation of the fittings, using **only** the clamp location shown in Figure 3, before installing the valve on the vehicle.
1. Clean and inspect all air lines and electrical harnesses for damage and replace as necessary. Select one of the two fitting installation methods, either bolt the valve onto the vehicle first, or clamp, as shown in Figure 3, using a bench vise.

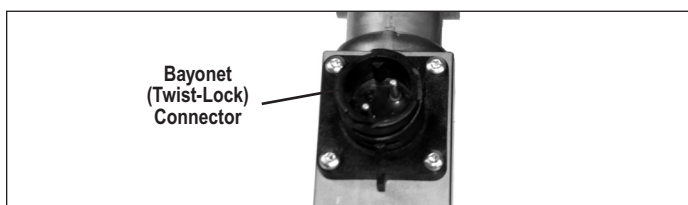

FIGURE 2 - THE BENDIX® AT-3™ SOLENOID VALVE - BAYONET CONNECTOR

2. With thread sealant applied, connect the (1/4-18 NPT) fitting to the Supply and Delivery ports at an initial torque of  $15 \pm 3$  ft. lbs. The fittings may be oriented clockwise, no more than one (1) additional turn to its final position.

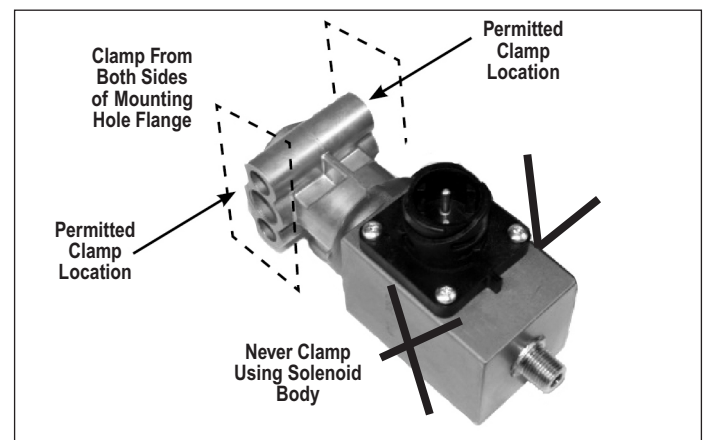

FIGURE 3 - VISE CLAMP LOCATION FOR BENCH INSTALLATION OF FITTINGS

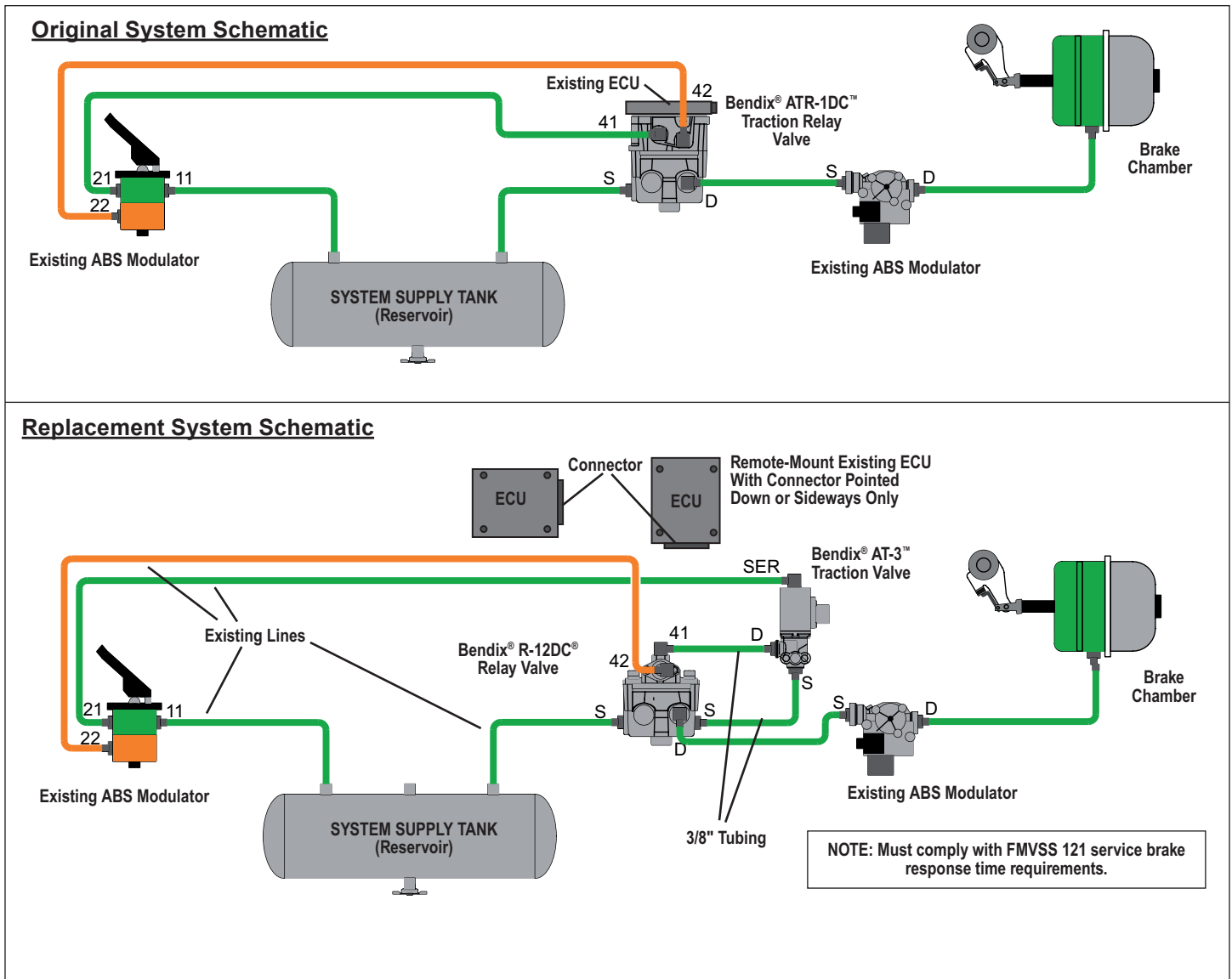

FIGURE 4 - **SYSTEM SCHEMATICS**

3. For vehicles where the service port is used, apply thread sealant to the fittings and tighten to 18 ft. lbs. (25 N•m).  
Where the fittings were installed using a bench vise, now bolt the valve onto the vehicle.
4. Reconnect the wire harness to the solenoid using the identification made during REMOVAL step. Be sure to check that the harness has sufficient tie-wraps, etc. to prevent any damage during vehicle operation.
5. Test valve as outlined in Operational and Leakage Tests.

2. In cases where the bracket supplied does not include mounting studs, install the bracket on the vehicle frame using grade 5 mounting bolts.
3. Inspect all lines and/or hoses for damage and replace as necessary.
4. Connect air lines to valve (plug any unused ports).
5. Test the valve as outlined in the *Operational and Leakage Test* section before returning the valve to service.

**INSTALLATION OF BENDIX® R-12DC® RELAY VALVE**

1. In most cases, the brackets supplied in the kit will allow the existing holes in the frame rail to be used. It will be necessary to remove two of the relay valve's cap screws to install the mounting bracket. Torque cap screws to 80-100 inch pounds.

## REMOTE-MOUNT OF EXISTING ELECTRONIC CONTROL UNIT (ECU)

1. Select a suitable location on a frame rail so that the existing harnesses can be used, bearing in mind any vehicle manufacturer's guidelines for mounting holes. Choose a location that is not subject to road-spray. Note that the ECU's connector must point either downwards or sideways after installation to help prevent water entering the electrical connectors.
2. Make a template of the four mounting holes for the ECU and mark and drill the frame.
3. Mount the ECU using grade 5 bolts and nuts. Torque to a maximum of 98 inch-pounds.

## OPERATIONAL AND LEAKAGE TESTS

1. Chock the wheels, fully charge air brake system and apply the brakes.
2. Coat the valves with a soap solution; leakage of a one-inch bubble in 3 seconds is permitted. (Where the Service Port is open to the atmosphere, do not spray the soap solution directly into this port, or snorkel tube, where installed.)

## OPERATION TEST

Since this valve is used for different functions depending on the vehicle, consult the vehicle Operator's Manual for further information. Also, refer to the Antilock Traction Controller's Service Data sheet (visit [www.bendix.com](http://www.bendix.com)) for operational test(s) for traction functionality. In addition, for certain vehicle air brake systems, a PC with the Bendix® ACom® Diagnostics software may be used to test the valve.



### **Bendix Technical Assistance Team**

For direct telephone technical support, call the Bendix Tech Team at:

1-800-AIR-BRAKE (1-800-247-2725),

Monday through Friday, 8:00 A.M. to 6:00 P.M. EST, and follow the instructions in the recorded message.

Or, you may e-mail: [techteam@bendix.com](mailto:techteam@bendix.com)

Please have the following information ready when you call: Bendix product model number, part number and configuration, vehicle make and model, vehicle configuration (number of axles, tire size, etc.).

### **Reference:**

The full Service Data sheet for the Bendix® ATR-6™ Traction Relay Valve is SD-13-4861 (BW2598) and is available for download on [www.bendix.com](http://www.bendix.com), or you can order copies from the Literature Center at the website.