



SERVICE MANUAL

COMPRESSOR WITH CLUTCH
SCANIA APPLICATION



TRUCKSERVICES

Disclaimer

The information contained in this document is intended for the exclusive use of trained persons within the commercial vehicle industry, and must not be passed on to any third party. All recommendations regarding products and their servicing or usage are with reference to Knorr-Bremse products and should not be considered applicable to products from other manufacturers.

This information does not purport to be all-inclusive and no responsibility is assumed as a result of its use. We cannot accept any liability nor offer any guarantee regarding data accuracy, completeness or timeliness. The information does not represent any guarantee or ensured characteristics of the Products or Systems described. No liability can be accepted based on the information, its use, recommendations or advice provided. In no event may we be held liable for any damage or loss except in the case of wilful intent or gross negligence on our part, or if any mandatory legal provisions apply.

Any legal disputes arising from the use of this information shall be subject to German law.

Note: If service work is carried out on the vehicle, it is the responsibility of the workshop to ensure the vehicle is fully tested and in full functional order before the vehicle is returned into service. Knorr-Bremse accepts no liability for problems caused as a result of appropriate tests not being carried out.

This disclaimer is an English translation of a German text, which should be referred to for all legal purposes.

Revision Details

Rev. 000

October 2020

New document



TRUCKSERVICES

SAFETY AND ENVIRONMENT GUIDELINES	4
1 DESCRIPTION AND FUNCTION	7
1.1 Sectioned View	7
1.2 Pneumatic Connections	8
1.2 Components and Function Description	9
2 GENERAL SPECIFICATIONS.	11
2.1 Instructions for Service and Repair Measures	11
2.2 Identification	11
2.3 Service Kits	12
2.4 Tightening Torques	12
2.4 Special Tools	13
3 TROUBLESHOOTING.	15
4 CHECKS AND SERVICING PROCEDURES	16
4.1 Test/Checks	17
4.1.1 Checking for leaks in the compressed air system.	17
4.1.1 Checking the delivery rate of the compressor	17
4.1.3 Checking cut-out of the compressor	18
4.1.4 Visual inspection of the bearing cover	19
4.1.5 Visual inspection of drive wheel of compressor	19
4.1.6 Visual inspection of housing and check for play in the teeth (clutch housing)	20
4.1.7 Checking oil spillage	20
4.1.8 Inspecting the clutch (13)	20
4.1.9 Inspecting crankcase (17) and actuation piston (15).	21
4.2 Compressor Replacement	22
4.2.1 Compressor removal from vehicle	22
4.2.2 Compressor installation onto vehicle	22
4.2.3 Assembly of compressor unit with clutch	22
4.3 Clutch (13) and Actuation Piston (15) Replacement - Service kit 2.1	24
4.3.1 Removal of clutch (13)	24
4.3.2 Removal of bearing (14) and actuation piston (15).	26
4.3.3 Replacing the clutch (19) - Service Kit 2.1	27
4.4 Servicing the Valve Plate (8), Cylinder Head (4) and Gaskets – Service Kits 1.1 / 1.2 / 1.4.	31
4.4.1 Removing cylinder head (4) and inlet reeds (9).	31
4.4.1 Assembly of cylinder head (4) and inlet reeds (9).	32
4.5 Leakage Test	35
4.6 Gear and Clutch Housing (12) Replacement – Service Kit 2.2.	35
4.6.1 Dismounting the drive gear (12) and the clutch pack (13).	35
4.7 Piston Replacement - Service Kit 1.3	38

SAFETY AND ENVIRONMENT GUIDELINES

Note: The safety advice listed below is applicable to general service and diagnostic work on braking systems. Also observe any recommendations from the axle or vehicle manufacturer concerning towing, jacking-up and securing the vehicle.

CAUTION: KNORR-BREMSE IS NOT LIABLE FOR ANY INJURIES OR DAMAGES CAUSED BY IMPROPER USE OF SPECIFIED SERVICE KITS AND/OR SERVICE TOOLS. FURTHERMORE, MISUSE OF TOOLS OR INCORRECT INSTALLATION OR APPLICATION OF SERVICE KITS MAY RESULT IN DAMAGE OR POTENTIALLY UNSAFE VEHICLE OPERATIONS. IN THIS CASE, KNORR-BREMSE DOES NOT HAVE ANY WARRANTY OBLIGATIONS.

Before and whilst working on or around compressed air systems and devices, the following precautions should be observed, along with the many hazard notes contained throughout the document:

- 1 Always wear safety glasses when working with air pressure.
- 2 Never exceed the vehicle manufacturer's recommended air pressures.
- 3 Never look into air jets or direct them at anyone.
- 4 Never connect or disconnect a hose or line containing pressure; it may whip as air escapes.
- 5 When removing or servicing a product, ensure all pressure related to the specific system it is contained in has been depleted to 0 bar. Be aware that if the vehicle is equipped with an air dryer system, it can also contain air pressure along with its purge reservoir, if fitted, even after pressure has been drained from the other reservoirs.
- 6 If it is necessary to drain the air pressure from reservoirs, etc., keep away from brake actuator push rods and levers since they may move as system pressure drops. On vehicles fitted with air suspension, it is advised when undertaking such work, to support the chassis from sudden lowering and therefore prevent any possibility of being trapped between the chassis and axle or ground.
- 7 Park the vehicle on a level surface, apply the parking brakes, and always chock the wheels as depleting vehicle air system pressure may cause the vehicle to roll.
- 8 When working under or around the vehicle, and particularly when working in the engine compartment, the engine should be shut off and the battery disconnected. Where circumstances require that the engine be running, EXTREME CAUTION should be taken to prevent personal injury resulting from contact with moving, rotating, leaking, heated or electrically charged components. Additionally, it is advisable to place a clear sign on or near the steering wheel advising that there is work in progress on the vehicle.
- 9 When working on vehicles equipped with air suspension, to guard against injury due to unexpected downward movement of the chassis caused by sudden pressure loss in the suspension system, ensure that the vehicle chassis is mechanically supported with a 'prop' between the chassis and the axle or between the chassis and the ground.
- 10 Examine all pipework for signs of kinks, dents, abrasion, drying out or overheating. Be aware that kinks in pipework may result in air pressure being trapped in the pipework and associated equipment. Replacement hardware, tubing, hose, fittings, etc. must be of equivalent size, type and strength as original equipment and be designed specifically for such applications and systems. Check the attachment of all pipework; it should be installed so that it cannot abrade or be subjected to excessive heat.
- 11 Components with stripped threads or damaged/corroded parts must be replaced completely. Do not attempt repairs requiring machining or welding unless specifically stated and approved by the vehicle or component manufacturer.
- 12 Never attempt to install, remove, disassemble or assemble a device until you have read and thoroughly understood the recommended procedures. Some units contain powerful springs and injury can result if not properly dismantled and reassembled. Use only the correct tools and observe all precautions pertaining to use of those tools.
- 13 Before removing any device note its position and the connections of all pipework so that the replacement/serviced device can be properly installed. Ensure that adequate support or assistance is provided for the removal/installation of heavy items.
- 14 Use only genuine replacement parts, components and kits as supplied by Knorr-Bremse or the vehicle manufacturer. Only use the recommended tools as specified in related Knorr-Bremse instructions.
- 15 The serviced or replaced product must be checked for correct function and effectiveness.
- 16 If products have been dismantled, serviced or replaced, whose performance could affect braking performance or system behaviour, this should be checked on a roller dynamometer. Bear in mind that a lower performance may be experienced during the bedding-in phase if new brake pads/linings and/or brake discs/drums have been fitted.
- 17 The use of impact screwdrivers or impact wrenches in conjunction with Knorr-Bremse service tools for air disc brakes is not permitted. The service tools are not designed for such use. It is likely that the tools or the vehicle will be damaged and there is a serious risk of injury – see Caution above.
- 18 Do not use compressed air to clean the disc brake. Avoid air contamination of brake dust.
- 19 Prior to returning the vehicle to service, make certain that all components and the complete brake systems are leak free and restored to their proper operating condition.

Welding

To avoid damage to electronic components when carrying out electrical welding, the following precautions should be observed:

- 1 In all cases, before starting any electrical welding, remove all connections from any electronic control units or modules, noting their position and the order in which they are removed.
- 2 When re-inserting the electrical connectors (in reverse order) it is essential that they are fitted to their correct assigned position - if necessary this must be checked by PC Diagnostics.



Disposal of Waste Equipment by Business Users in the European Union

This symbol on the product, packaging or in user instructions, indicates that this product must not be disposed of with other general waste. Instead, it is your responsibility to dispose of the waste electrical and electronic parts of this product by handing them over to a company or organisation authorised for the recycling of waste electrical and electronic equipment. For more information about arrangements for waste equipment disposal please contact your Knorr-Bremse distributor or local Knorr-Bremse representative.



1 DESCRIPTION AND FUNCTION

1.1 Sectioned View

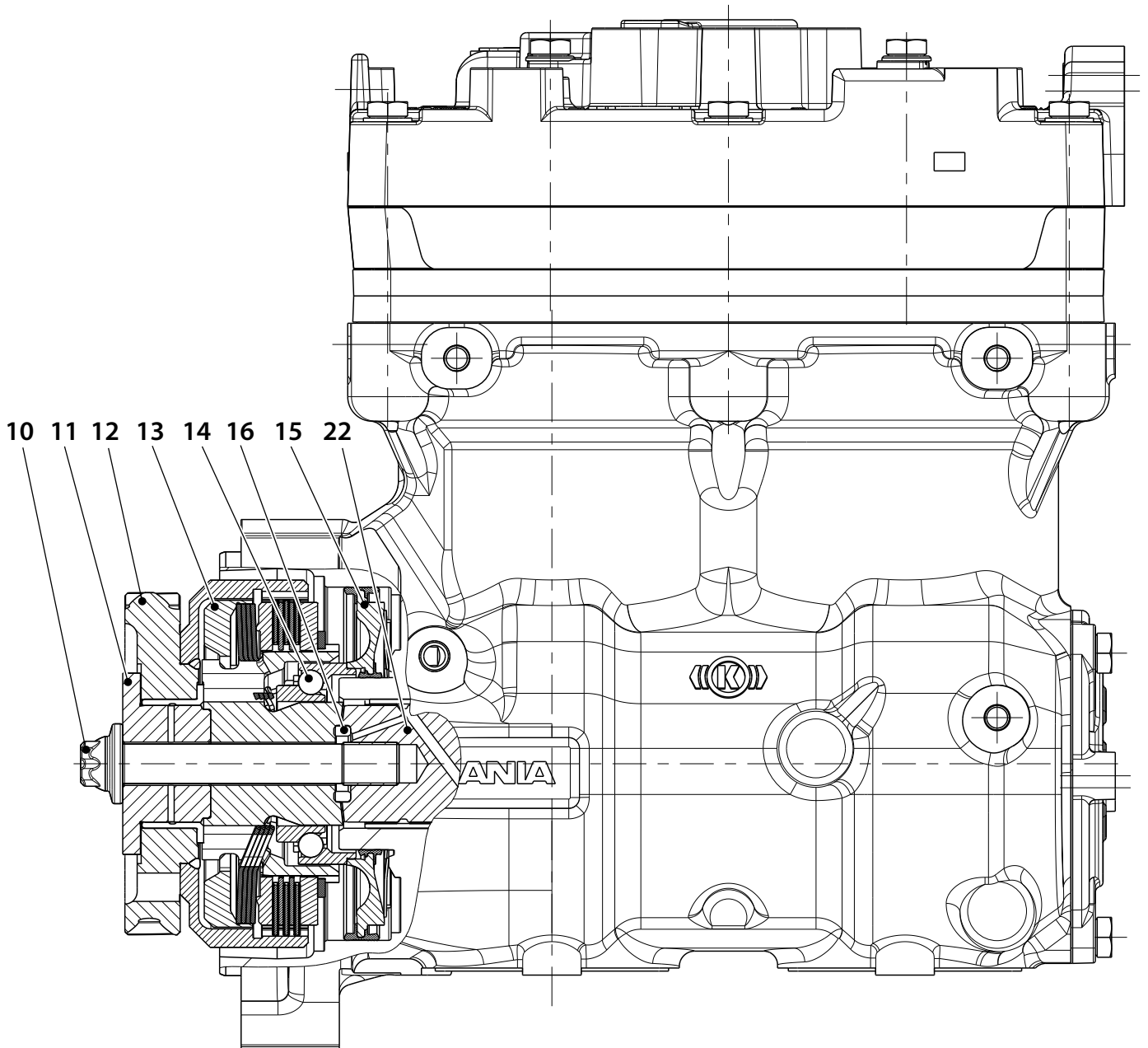

Legend

- | | | | |
|----|-------------------------|----|-------------------------|
| 10 | Fastening Bolt M14x90 | 15 | Clutch actuation piston |
| 11 | Gear support | 16 | Hirth gasket |
| 12 | Gear and clutch housing | 22 | Crankshaft |
| 13 | Clutch pack | | |
| 14 | Bearing | | |

1 DESCRIPTION AND FUNCTION

1.2 Pneumatic Connections

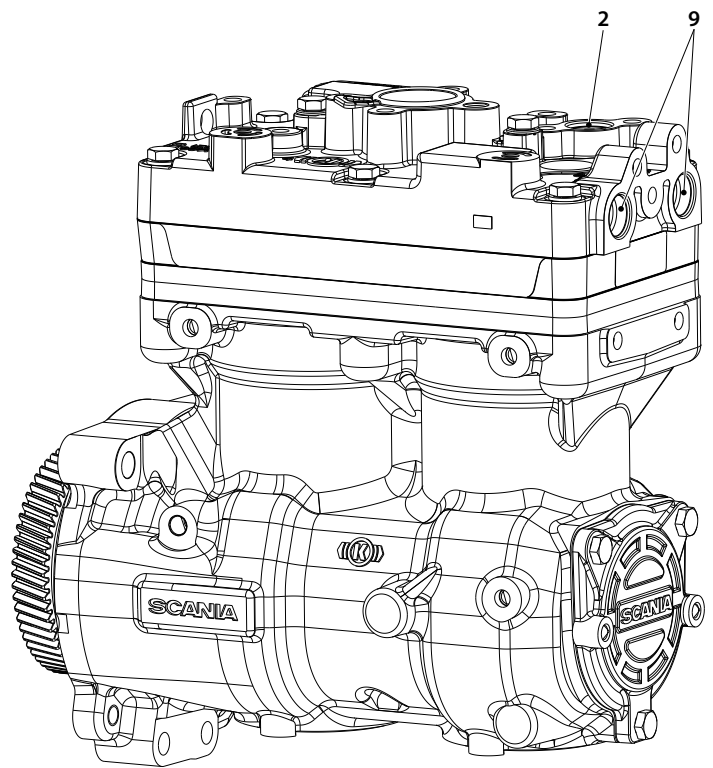
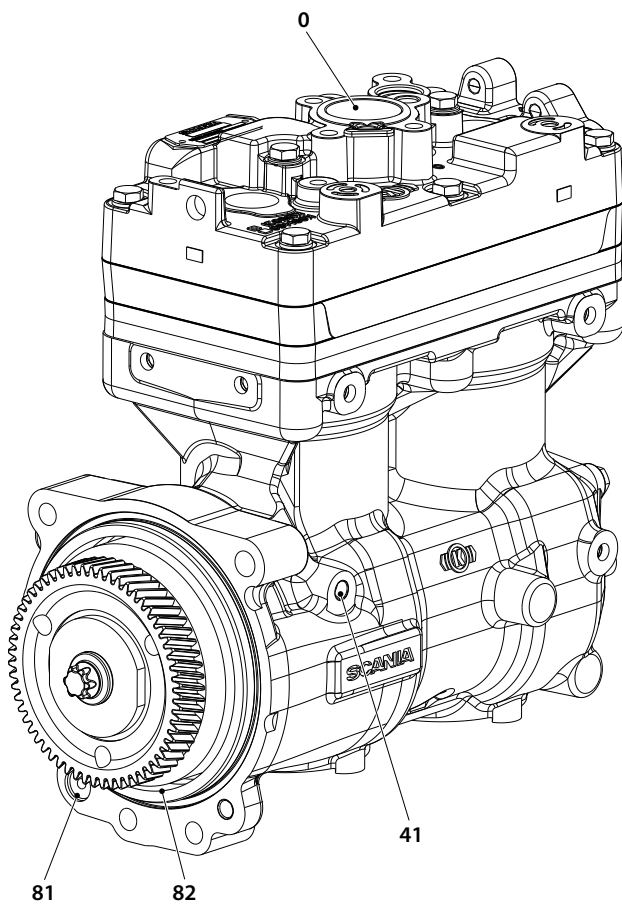

Legend

- 0 Intake connector
- 2 Energy discharge (pressure line)
- 41 Clutch actuation
- 81 Lubricant feed
- 82 Window for lubricant return to engine circuit
- 91 Coolant feed
- 92 Coolant discharge

1.2 Components and Function Description

Pos	Legend	Qty
1	O-ring Ø34.2x3	1
2	Screw M8x85	2
3	Screw M8x85	6
4	Cylinder head	1
5	Cylinder head gasket	1
6	Cooling plate	1
7	Gasket	1
8	Valve plate	1
9	Inlet reed	1

Pos	Legend	Qty
10	Fastening bolt M14x90	1
11	Gear Support	1
12	Gear and clutch housing	1
13	Clutch pack	1
14	Bearing	1
15	Clutch actuation piston	1
16	Hirth gasket	1
17	Crankcase	1
18	Sump plate gasket	2

Pos	Legend	Qty
19	Sump plate/plug	2
20	Screw M6x12	8
21	Thrust washer	1
22	Crankshaft	1
23	O-ring Ø82x3	1
24	Rear cover	1
25	Screw M8x20	3
26	Con-rod	2
27	Piston	2

* Alternative for position 19

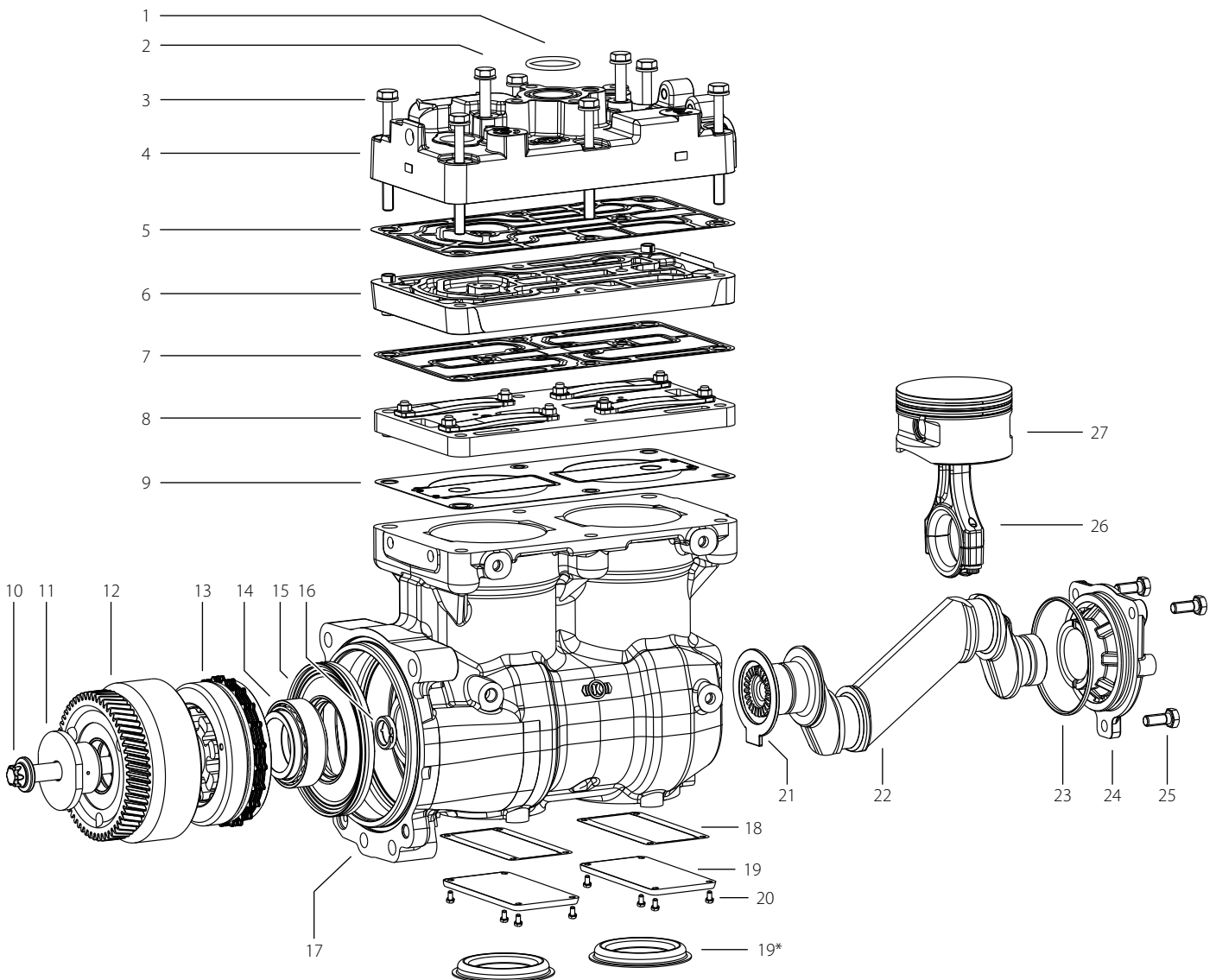

1 DESCRIPTION AND FUNCTION

Construction

The compressor with clutch consists mainly of the drive gear (12), the clutch pack (13), and the compressor unit.

The drive gear (12), on which is fixed a drum, is connected to the engine and transfers the torque to the drum which is connected to the clutch (13) via the drum, which is toothed on its interior.

The clutch (13) is screwed onto the crankshaft (22) and is controlled using the actuation piston (15) which seals compressed air on the one side and oil on the other.

The crankshaft drive, consisting of the crankshaft (22) and connecting rod (26), converts the rotary movement into an up-and-down movement. The force is transmitted through the Connecting rod to the piston (27), which slides up and down in the cylinder. The valve plate (8), the cooling plate (6) and the cylinder head (4) are water-cooled.

Function

Delivering phase

As the piston moves downwards, the intake valve (9) under the valve plate opens and ambient air flows in through intake connection 0. Once the piston reaches its lowermost position (lower dead point = LDP), the intake valve closes and the piston starts its upwards movement. During the upwards movement, the air is compressed in the ever smaller space between the piston and the valve plate.

Once a certain pressure has been achieved, the outlet valves on the valve plate (8) open, and the compressed air is forced through pressure connection 2 into the pressure line. To lubricate the bearings, the compressor is connected to the oil circulation of the engine through lubrication oil intake 81 and outlet 82. Oil channels in the housing and in the crankshaft allow the lubricating oil to reach the sliding and connecting rod bearings.

The other bearing points are lubricated by sprayed oil or the oil mist in the crankcase. The cooling water flows through connection 91 into the cylinder head (4), the cooling plate (6) and the valve plate (8), so that the heat generated during compression process can be transferred through the walls into the cooling water. The coolant leaves the cylinder head through connection 92.

Clutch opens

Once the cut-out pressure is achieved, connection 4/23 of the air dryer is vented. The actuation piston (15) is vented and presses the release bearing (14) against the clutch (13). The clutch (13) breaks the connection between the driven gear with clutch housing (12) and crankshaft (22). The entire crankshaft drive and the piston are no longer driven.

Clutch closes

If the pressure in the system falls below the cut-in pressure of the pressure regulator, the connection 4/23 is opened. The actuation piston (15) is released. The clutch (13) closes and the compressor delivers air again.

2 GENERAL SPECIFICATIONS

2.1 Instructions for Service and Repair Measures

A Trouble Shooting table in chapter 3 helps advise which maintenance tasks and service kits are required for a specific cause, and references the section within this manual showing the step-by-step procedure.

By the design of the service manual, service personnel are made aware of the possible risks of damage to parts if due care and correct procedures are not adhered to.

After each repair action, the error-free function of the system must be checked to see whether or not the error has been corrected. The condition of the compressor with clutch depends primarily on its peripherals. This means that the air filters, intake lines, pressure lines, any leaks in the system, oil quality, oil pressure and the cooling system of the compressor must be in an error-free condition.

The service and oil change intervals specified by the vehicle manufacturer must strictly be followed.

The function of the clutch (13) is checked by filling the system until the cut-out pressure is reached. After the compressor drive is disconnected at the clutch and regeneration is complete, no compressed air should emerge from the ventilation of the air dryer. Follow the specifications of the vehicle manufacturer for the cut-in and cut-out pressure.

2.2 Identification

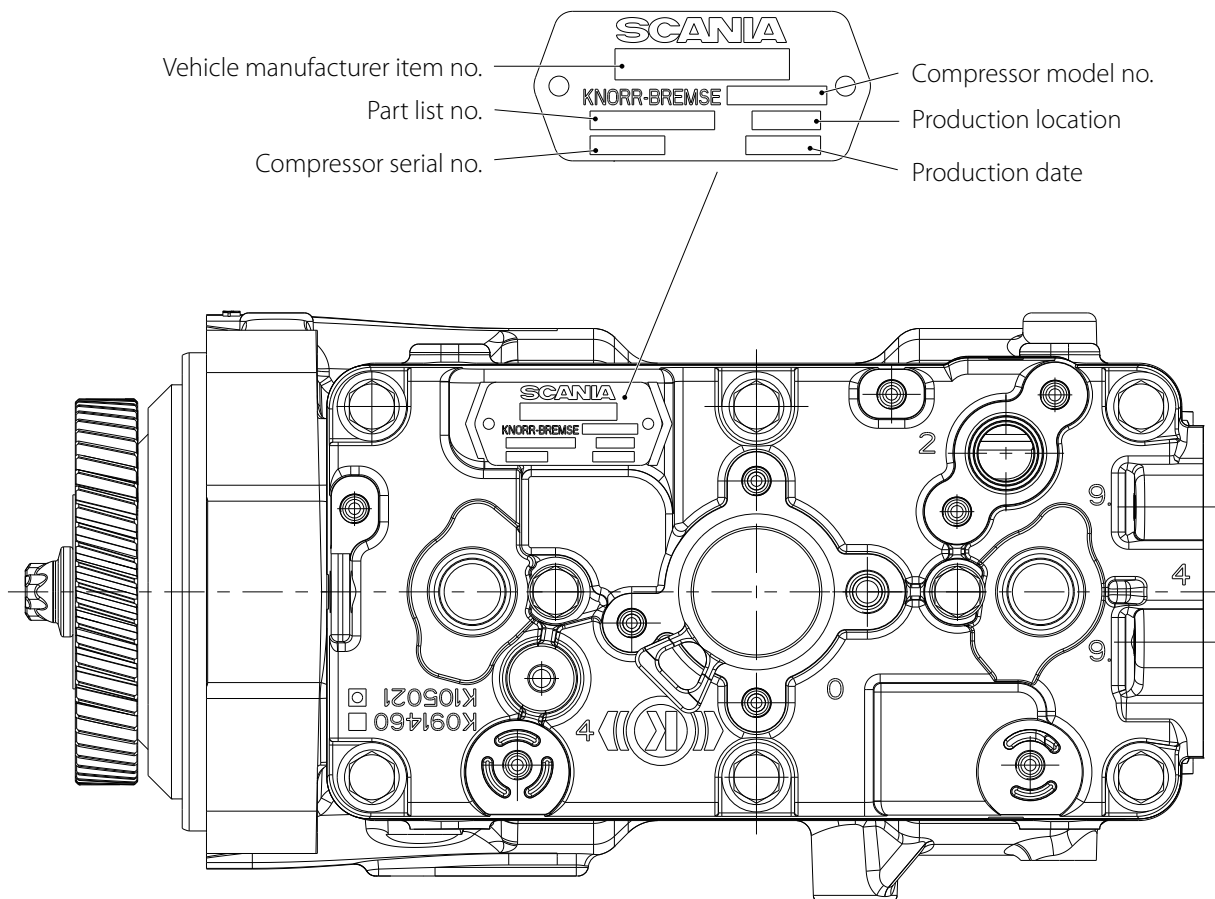

2 GENERAL SPECIFICATIONS

2.3 Service Kits

No.	Designation	Content (item no.)
1.1	Cylinder head kit	1, 2, 3, 4, 5, 6, 7, 9
1.2	Valve plate kit	2, 3, 5, 7, 8, 9
1.3	Pistons kit	2, 3, 5, 7, 9, 18, 19, 20, 23, 27
1.4	General maintenance kit	1, 2, 3, 5, 7, 9, 10, 16, 18, 19, 21, 23, 20, 25,
1.5	Complete cylinder head kit	1, 2, 3, 4, 5, 6, 7, 8, 9

No.	Designation	Content (item no.)
2.1	Clutch kit	10, 13, 14, 15, 16
2.2	Gear kit	10, 11, 12, 16

2.4 Tightening Torques

Item no.	Quantity	Installation location	Tightening torque	Wrench size
1	8	Cylinder cover	See figure below *	13 mm (hexagon)
26	4	Connecting rod	14 Nm	8 mm (outer star)
19	8	Sump plate	12 Nm	10 mm (hexagon)
10	1	Clutch fastening M12	25 Nm + 90°	Torx E18
10	1	Clutch fastening M14	25 Nm + 90°	Torx E18
24	3	Rear cover	23 Nm	13 mm (hexagon)

Tightening sequence for cylinder cover screws

In two phases:

1. 20 Nm
2. 25 Nm + 60°

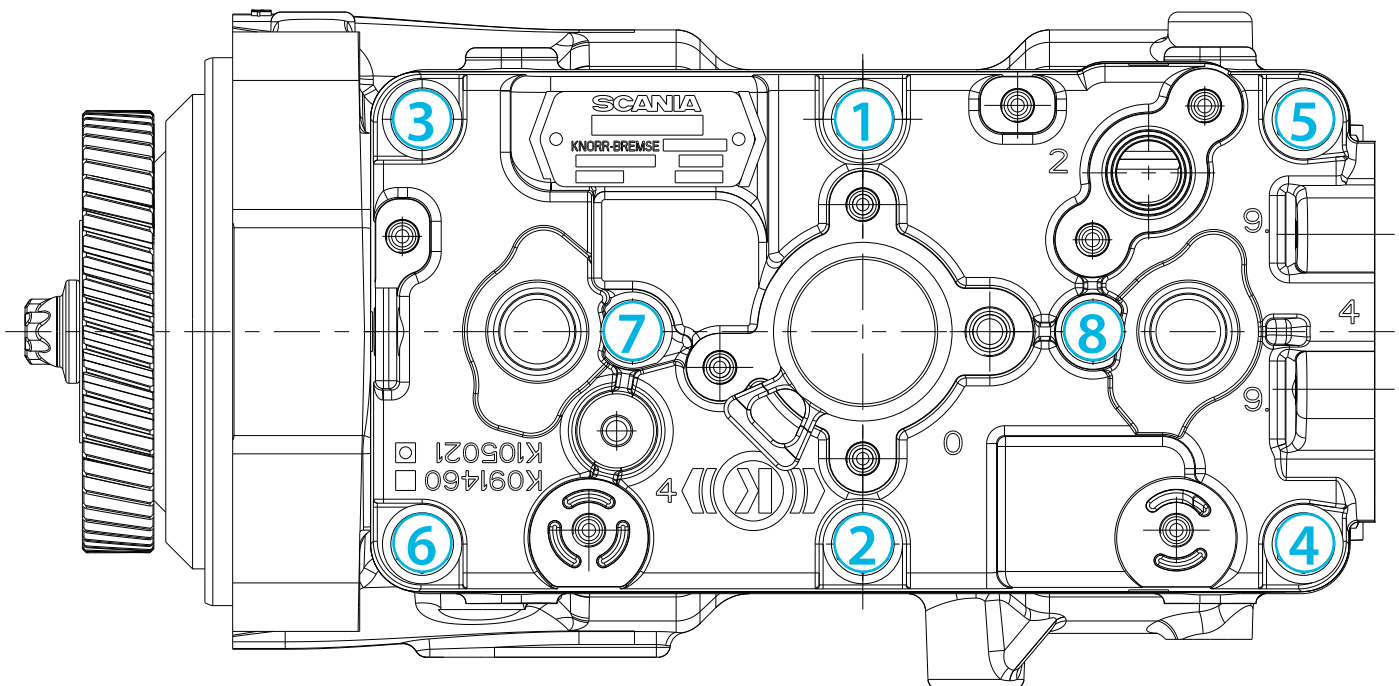

2.4 Special Tools

Clutch Compressor Tool Case K052066K50

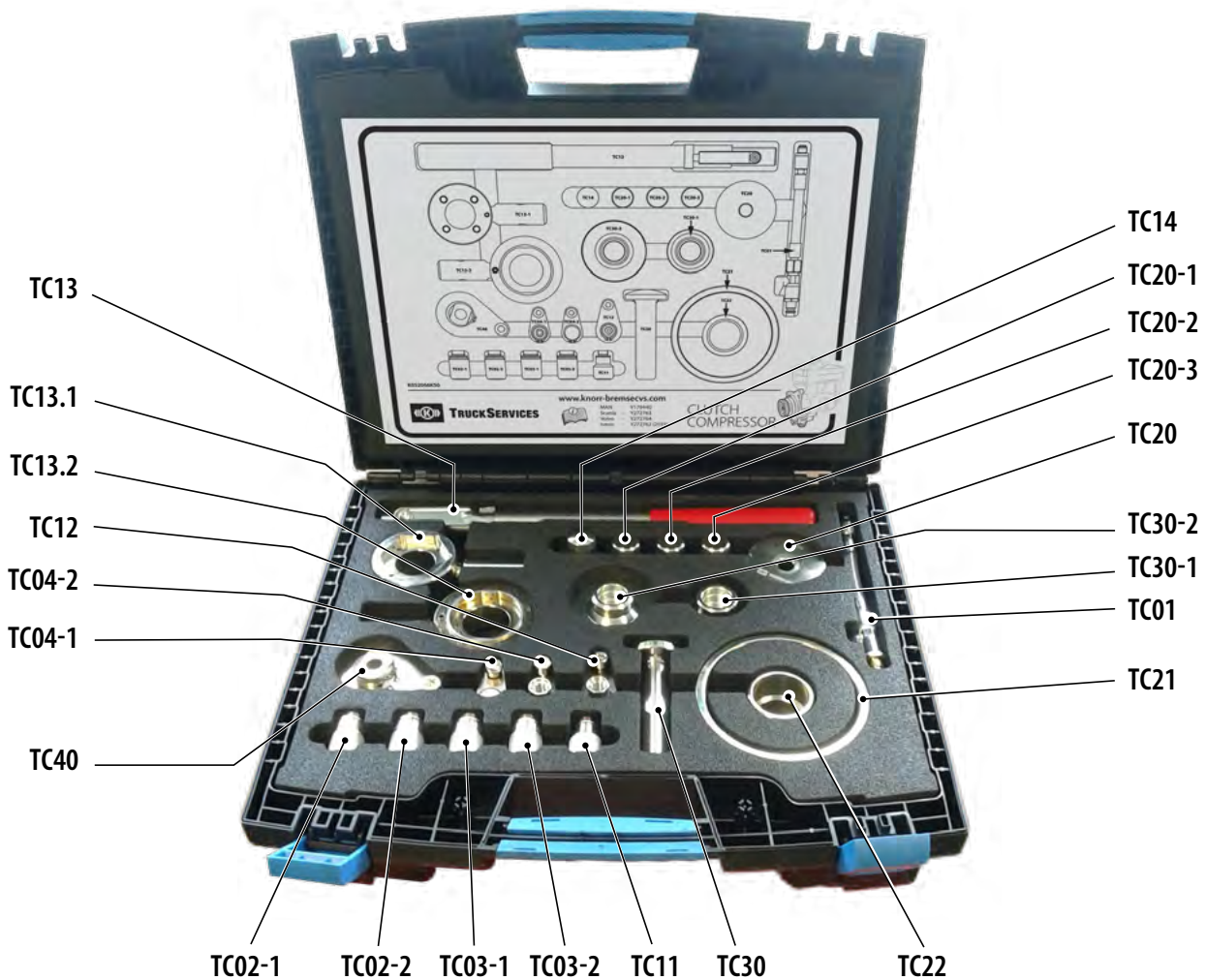

- TC02-1/ TC02-2/ TC03-1/ TC03-2 / TC11/ TC04-1/ TC04-2:** Adaptors to test the tightness of the Compressor
- TC12:** Adaptor for ventilating the clutch
- TC40:** Pressing-in tool for installing the retaining ring including backing plate for fastening the drive gear
- TC30/ TC30-1/ TC30-2:** Pressing-in tool for housing cover
- TC21/ TC22:** Installation aid for actuation piston
- TC01:** Ventilating hose
- TC20/ TC20-1/ TC20-2/ TC20-3:** Protective mechanism for pressing out the actuation piston
- TC14:** Pressing-out tool to disconnect the gear support
- TC13/ TC13-1/ TC13-2:** Socket wrench tool combination for installation and disassembly of the clutch

2 GENERAL SPECIFICATIONS

Special tool case layout

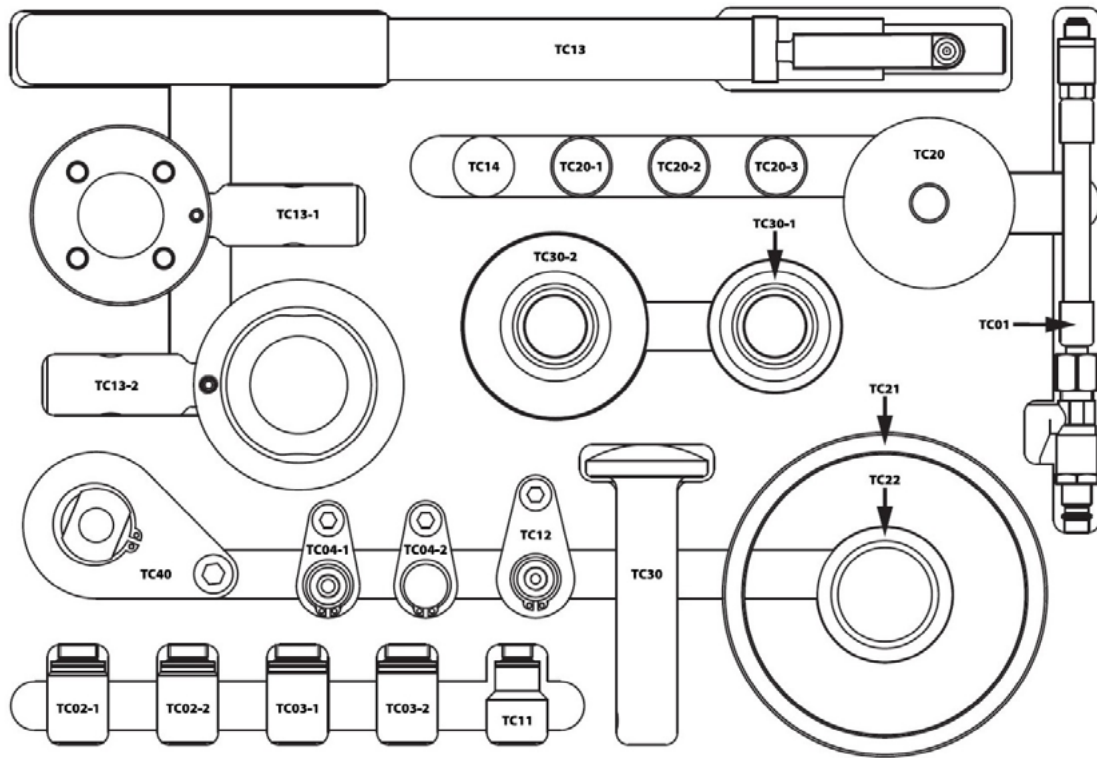

3 TROUBLESHOOTING

Problem	Cause	Action	See Section
No air pressure delivery	The clutch is sliding, thus the compressor doesn't run	Replace the clutch (complete kit)	4.3
	The compressor runs, but one of the valve plate reeds is broken	Replace the valve plate	4.4
	The driving gear or the clutch drum is broken	Replace the gear	4.6
	Internal parts, crankshaft, con-rod, . . . are broken	Replace the compressor and send the worn one to Knorr-Bremse for remanufacturing	4.2
Compressor delivers air but cut-off pressure is not reached	The compressor runs, but the clutch is sliding	Replace the clutch (complete kit)	4.3
	The compressor runs, but one of the valve plate reeds is broken	Replace the valve plate	4.4
	The compressor runs but there is a leakage in the air delivery circuit	Replace the gaskets	4.4
	Piston rings are worn out	Replace the pistons	4.7
	Piston rings and cylinder bores are worn out	Replace the compressor and send the worn one to Knorr-Bremse for remanufacturing	4.2
Filling time too long	The compressor runs, but the clutch is sliding	Replace the clutch (complete kit)	4.3
	The compressor cylinder head is clogged with carbon deposit	Replace the cylinder head	4.4
	The compressor runs, but one of the valve plate reeds is broken	Replace the valve plate	4.4
	The compressor runs but there is a leakage in the air delivery circuit	Replace the gaskets	4.4
	Piston rings are worn out	Replace the pistons	4.7
	Piston rings and cylinder bores are worn out	Replace the compressor and send the worn one to Knorr-Bremse for remanufacturing	4.2
Compressor continues to deliver compressed air even after the cut-out pressure is reached	The clutch actuating piston is worn out	Replace the clutch (complete kit)	4.3
Excessive oil emerging from silencer of air dryer	Piston rings are worn out	Replace the pistons	4.7
	Piston rings and cylinder bores are worn out	Replace the compressor and send the worn one to Knorr-Bremse for remanufacturing	4.2
Oil leakage at the compressor	The gaskets are broken or worn	Replace the gaskets	4.4
Excessive pressure built up in the cooling system	The cylinder head gaskets are broken or worn	Replace the gaskets	4.4
Loss of cooling water in the compressor	The cylinder head gaskets are broken or worn	Replace the gaskets	4.4

4 CHECKS AND SERVICING PROCEDURES

4.1	Test/Checks	17
4.1.1	Checking for leaks in the compressed air system.	17
4.1.1	Checking the delivery rate of the compressor	17
4.1.3	Checking cut-out of the compressor	18
4.1.4	Visual inspection of the bearing cover	19
4.1.5	Visual inspection of drive wheel of compressor	19
4.1.6	Visual inspection of housing and check for play in the teeth (clutch housing)	20
4.1.7	Checking oil spillage	20
4.1.8	Inspecting the clutch (13)	20
4.1.9	Inspecting crankcase (17) and actuation piston (15).	21
4.2	Compressor Replacement	22
4.2.1	Compressor removal from vehicle	22
4.2.2	Compressor installation onto vehicle	22
4.2.3	Assembly of compressor unit with clutch	22
4.3	Clutch (13) and Actuation Piston (15) Replacement - Service kit 2.1	24
4.3.1	Removal of clutch (13)	24
4.3.2	Removal of bearing (14) and actuation piston (15).	26
4.3.3	Replacing the clutch (19) - Service Kit 2.1	27
4.4	Servicing the Valve Plate (8), Cylinder Head (4) and Gaskets – Service Kits 1.1 / 1.2 / 1.4	31
4.4.1	Removing cylinder head (4) and inlet reeds (9).	31
4.4.1	Assembly of cylinder head (4) and inlet reeds (9).	32
4.5	Leakage Test	35
4.6	Gear and Clutch Housing (12) Replacement – Service Kit 2.2	35
4.6.1	Dismounting the drive gear (12) and the clutch pack (13).	35
4.7	Piston Replacement - Service Kit 1.3	38

4.1 Test/Checks

4.1.1 Checking for leaks in the compressed air system

Secure the vehicle so that it cannot roll away. Then release the parking brake.

Fill the air system until it reaches the cut-out pressure.

In the delivery phase, check for leaks in the line between the compressor and the air dryer.

Turn off the engine.

Check the pressure in the compressed air reservoirs.

Carry out a braking action with the service brake until a brake cylinder pressure of about 3bar is reached.

After one minute, measure the pressure in the compressed air reservoirs.

After another **3** minutes, this pressure may not have dropped more than **0.4bar**.

4.1.1 Checking the delivery rate of the compressor

Before measuring the delivery rate, you should first carry out the objective evaluation as follows:

Objective evaluation:

- Depressurize the system
- At the rated speed, the pressure must clearly rise in the reservoir of the service brake

If the objective evaluation shows a defective delivery rate from the compressor, measure the delivery rate as follows:

Measuring the delivery rate:

The following material is recommended for this test method:

- A 40 l compressed air reservoir with test connection
- 5 m line with 15 mm inner diameter
- Manometer (0-16 bar)
- Safety valve (12 bar)
- Valve to release pressure (e.g. a way valve)
- Stopwatch



Before removing a pressure line, release the pressure in the system. Even then, there can still be residual pressure in the pressure line.

Disconnect the pressure line from the compressor and connect the compressed air reservoir to the compressor with clutch using a 5 m long line of at least 15 mm inner diameter (see schematic).

Delivery rate schematic

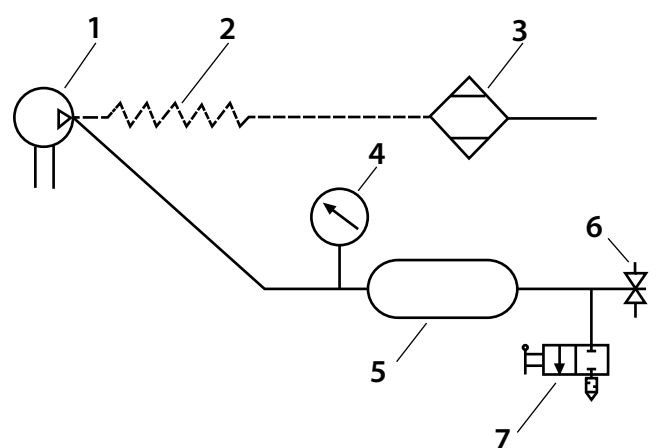

Legend:

1	Compressor with clutch	5	Compressed air reservoir
2	Cooling coil	6	Safety valve
3	Air dryer	7	Way valve
4	Manometer		

Fig. 4.1.2

4 CHECKS AND SERVICING PROCEDURES

Connect a manometer to the compressed air reservoir (see Fig. 4.1.2).

The compressed air container should also have a safety valve and a way valve downstream (to release the pressure – see schematic).

Start the engine and let it run at a constant engine speed of 700 rpm. Close the way valve.

Measure the time the compressor with clutch requires to increase the pressure in the reservoir from 5 to 10 bar.

The measured value must be under 70 sec (if using a 4 m x 12 mm manometer line; about 450 cm³).

To repeat or finish the test, the reservoir should be depressurized using the two-way valve.

4.1.3 Checking cut-out of the compressor

Connect the adaptor (TC02-1) to the clutch actuation port. Start the engine and ventilate the clutch actuation piston (15) with external air (8 -10 bar).

Note: Ventilating the clutch with the engine running must be carried out in significantly less time than one second to avoid the clutch slipping.



Fig. 4.1.3

4.1.4 Visual inspection of the bearing cover

Check the bearing cover (24), for oil leaks. For tightening torques and sequence see **Section 2.4**.



Fig. 4.1.4

4.1.5 Visual inspection of drive wheel of compressor

Examine the gear teeth of the gear and housing unit (12) of the compressor.

Check for excessive wear.

If excessive wear is found, the available service kits should be considered - **Service Kit 2.2**

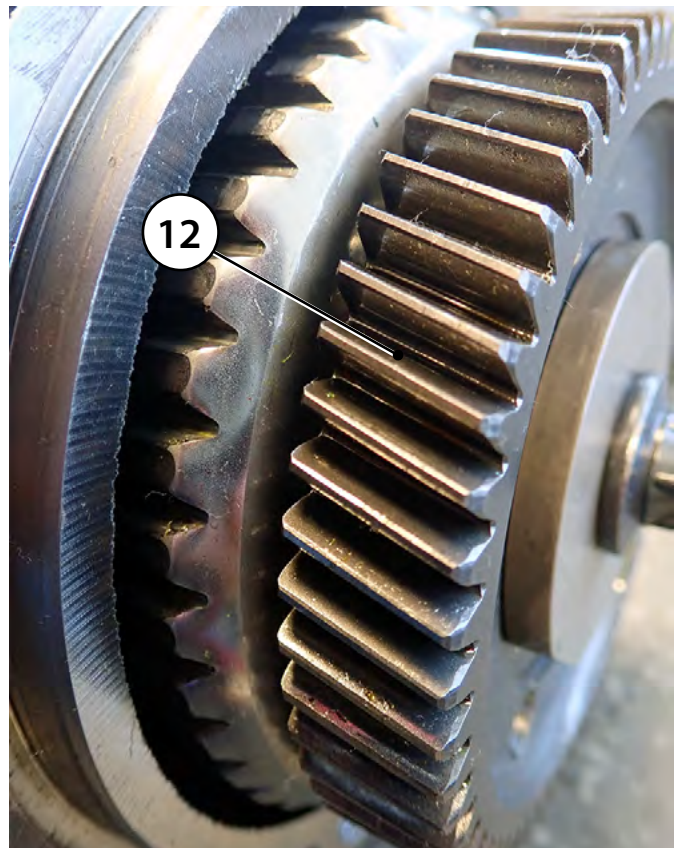

Fig. 4.1.5

4 CHECKS AND SERVICING PROCEDURES

4.1.6 Visual inspection of housing and check for play in the teeth (clutch housing)

Examine the housing teeth of the gear and housing unit (12) by disconnecting the clutch unit (13) from the compressor. Check the teeth for excessive wear, check also for metal chips that may have lodged on the gear teeth.

If excessive wear is found, the available service kits should be considered - **Service Kit 2.2**

Note: *The wear condition of the teeth in the figure is acceptable.*

Also check whether the play between the clutch teeth (13) and the housing (12) is excessively large.



Fig. 4.1.6

4.1.7 Checking oil spillage

Check the oil spillage.

To do this, download the document “**Compressor oil carry over**” from our website and carry out the test described in point “**Test 11**”(paper test).

Document number: **Y037387** www.Knorr-BremseCVS.com

4.1.8 Inspecting the clutch (13)

For the clutch (13) to be further inspected, it must be removed – see **Section 4.3.1**

Carry out a visual inspection of the clutch (13).

Look for damage in the form of thermal overloads (discoloration), deformations, scratches, chips, etc.

If excessive wear is found, the available service kits should be considered - **Service Kit 2.1**

Be sure that there is a gap (about **1 mm**) between the spring bundle and the clutch housing (12). If there is an inadmissible level of wear, the spring package is in contact with the clutch housing.

Note: *The figure shows acceptable wear, since there is a visible gap between the spring bundle and the clutch housing (see arrows).*

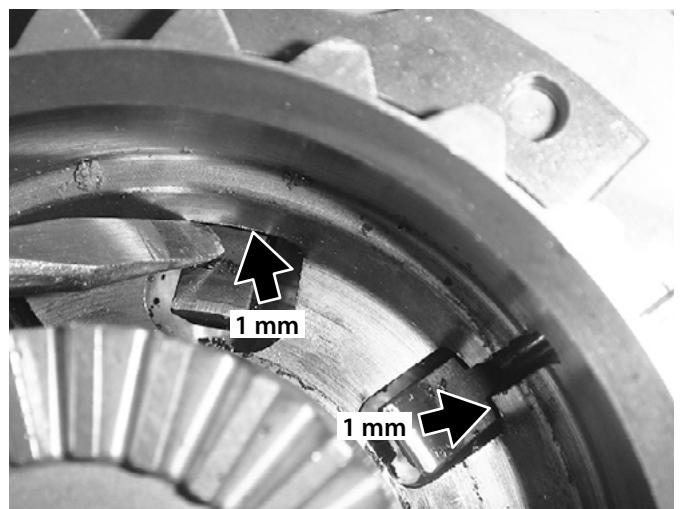

Fig. 4.1.8

4.1.9 Inspecting crankcase (17) and actuation piston (15)

After dismantling the clutch (13) - **see Section 4.3**, the crankcase (17) and the actuation piston (15) can be inspected.

Clean the crankcase (17) and the actuation piston (15).

Check the area of the running surface of the crankcase (17) as well as the sealing surface of the actuation piston (15).

Look for damage in the form of scratches and residue of metal chips.

If excessive wear is found, the available service kit should be considered - **Service Kit 2.1**

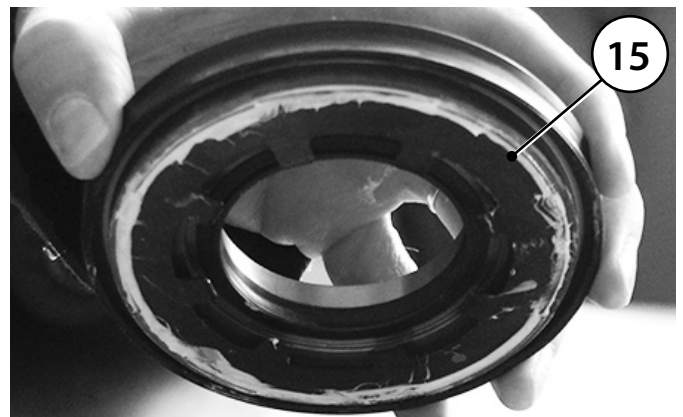
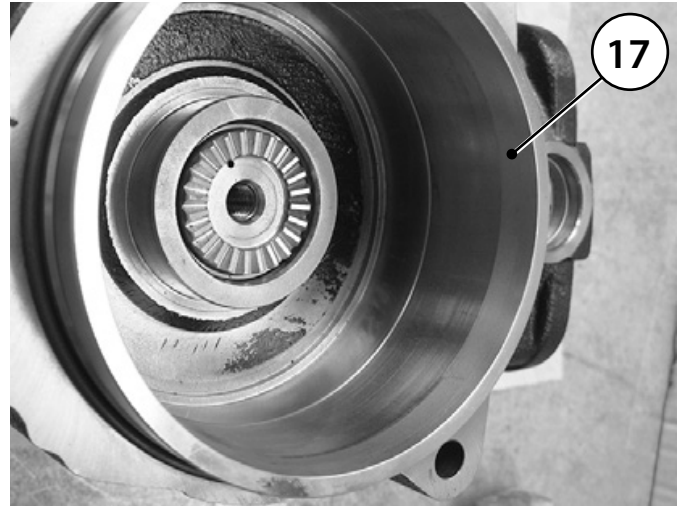

Fig. 4.1.9

4 CHECKS AND SERVICING PROCEDURES

4.2 Compressor Replacement

4.2.1 Compressor removal from vehicle

Depending on the vehicle equipment, it may be necessary before removing the compressor with clutch to dismount other components from the vehicle. Follow the manufacturer's instructions.

Dismount the compressor with clutch. Follow the manufacturer's instructions.

4.2.2 Compressor installation onto vehicle

Before installing the compressor unit with clutch, be sure that the flange surfaces are clean and undamaged.

Place a new O-ring in the flange groove and in the oil inlet port.

Mount the compressor with clutch.

Be sure that the connection to the engine is sealed.

For installation into the vehicle, follow the manufacturer's instructions.

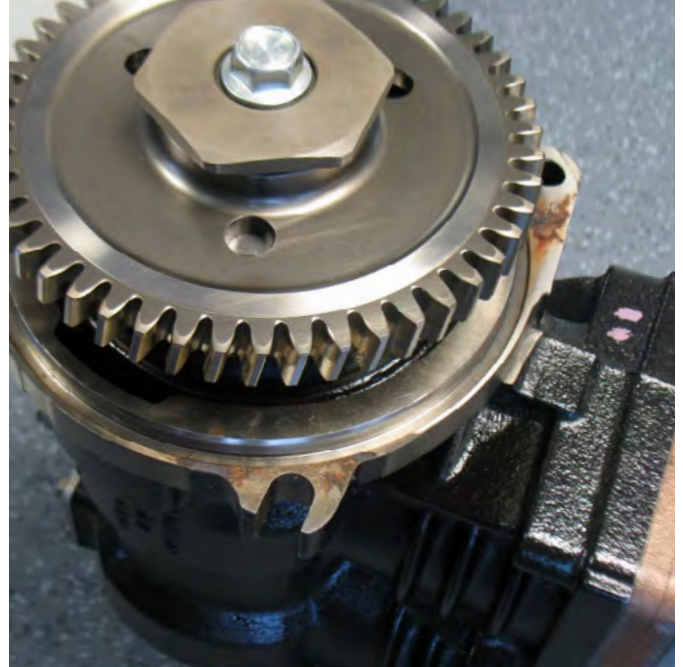

Fig. 4.2.1

4.2.3 Assembly of compressor unit with clutch

4.2.2.1 Clean the installation area.

4.2.2.2 Examine the teeth on the inside of the clutch housing (12).

If marks from the clutch teeth can be seen **in every groove** of the housing, the clutch housing (12) must be replaced – see **Section 4.6 - Service Kit 2.2**

If marks can be seen **in every second groove** of the housing, the clutch housing (12) can continue to be used for a second period.

In general: To avoid damage when joining the clutch housing onto the clutch due to an inaccurate fit of the clutch teeth into the clutch housing, proceed as follows:

4.2.2.3 Mark one groove of the clutch housing (12) that shows no marks from the clutch teeth --- see arrow

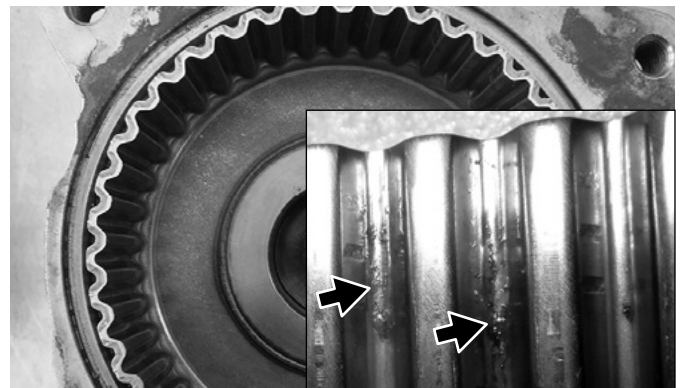

Fig. 4.2.2.2

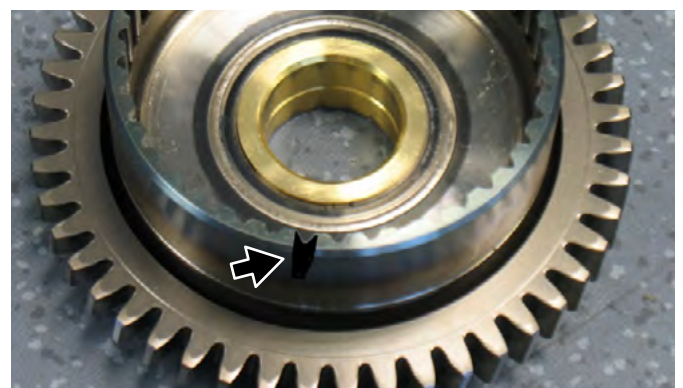

Fig. 4.2.2.3

4.2.2.4 Mark the position of one tooth of the clutch (13) on the crankcase (17) --- see arrow in figure.

The clutch (13) may no longer be turned!

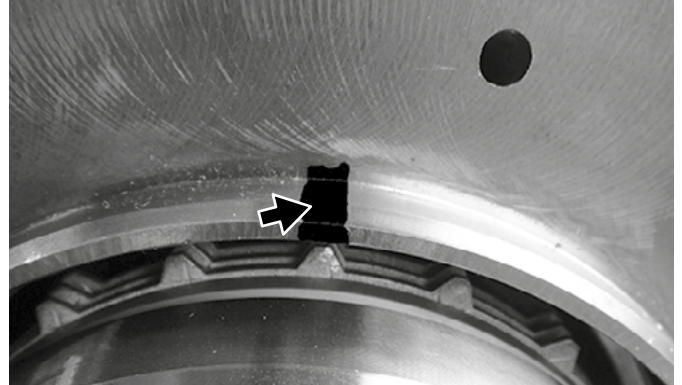

Fig. 4.2.2.4

4.2.2.5 Line up the marks and push together the clutch housing (12) and the crankcase (17) with clutch (13) onto one another.

Note: Be sure the marks are lined up before pushing together.



Fig. 4.2.2.5

4 CHECKS AND SERVICING PROCEDURES

4.3 Clutch (13) and Actuation Piston (15) Replacement - Service kit 2.1

Tools required:

- TC13/TC13-2:** Socket wrench tool combination for installation and disassembly of the clutch
- TC20/TC20-2:** Protective mechanism for pressing out the actuation piston
- TC21/TC22:** Installation aid for actuation piston
- TC14:** Pressing-out tool to disconnect the gear support

Torque wrench: For clutch replacement (Note: not included in the special tool case)

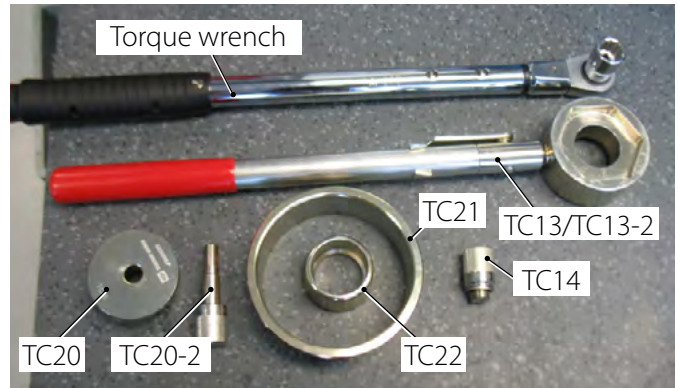

Fig. 4.3

4.3.1 Removal of clutch (13)

4.3.1.1 Place the special tool combination (TC13/TC13-2) onto the gear support (11) as shown, in preparation of removing the fastening bolt (10).

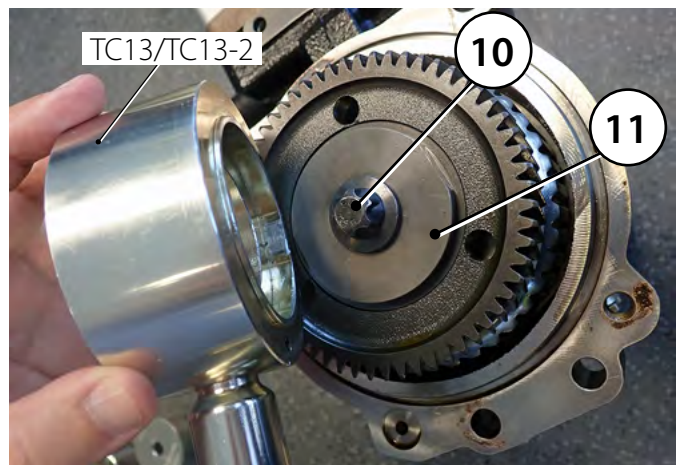

Fig. 4.3.1.1

4.3.1.2 Whilst holding tool combination (TC13/TC13-2) in position, unscrew the fastening bolt (10) using a suitable torque wrench (18 mm).

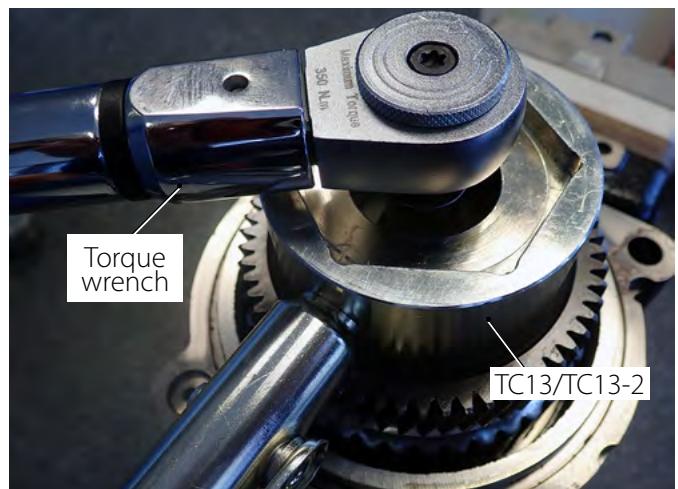

Fig. 4.3.1.2

4.3.1.3 Remove the clutch (11+12+13)

Note: At this point the bearing (14) and actuation piston (15) can be replaced if necessary as follows:



Fig. 4.3.1.3

4.3.1.4 Separate the clutch from its housing, using tool **TC14** and a suitable hammer.

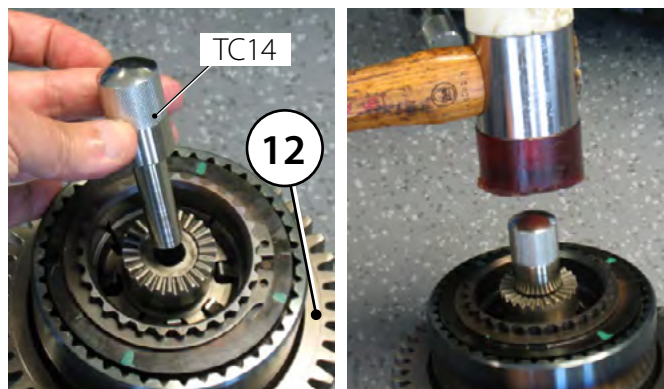

Fig. 4.3.1.4

4 CHECKS AND SERVICING PROCEDURES

4.3.2 Removal of bearing (14) and actuation piston (15)

4.3.2.1 Remove the bearing (14) and the Hirth gasket (16).

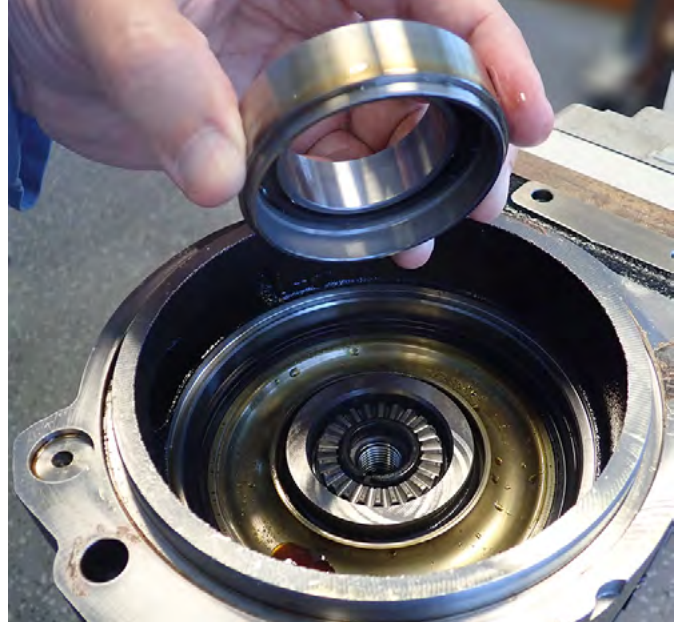

Fig. 4.3.2.1

4.3.2.2 Place tool (TC20) onto the crankshaft (22).



Fig. 4.3.2.2

4.3.2.2 Hand-tighten in place using tool **TC20-2** or **TC20-x** depending on thread **M12** or **M14**

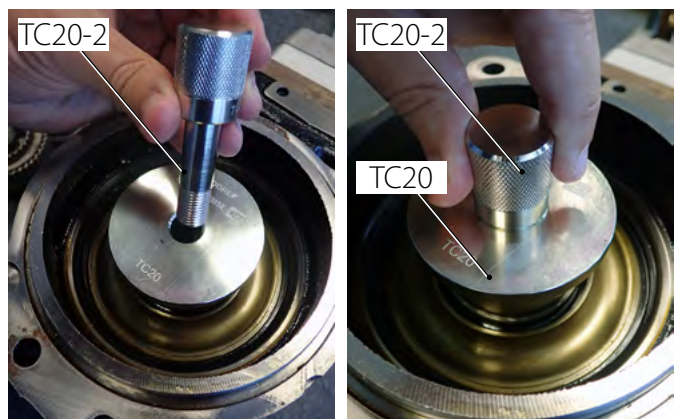

Fig. 4.3.2.3

4.3.2.2 Gradually and carefully press out the actuation piston (15) by repeatedly ventilating and turning tool (TC20).

The actuation piston (15) can only be dismantled via tool (TC20)

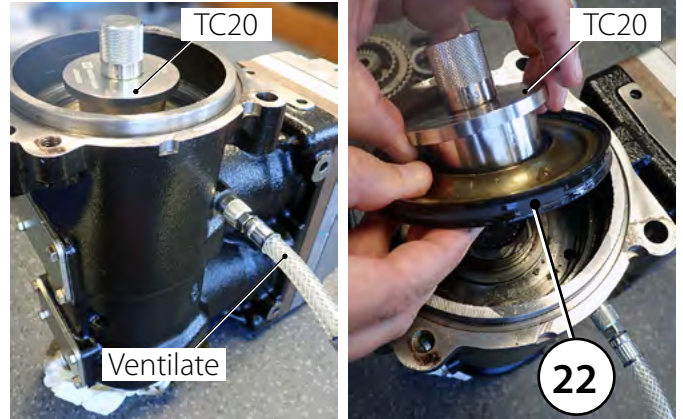

Fig. 4.3.2.3

4.3.3 Replacing the clutch (19) - Service Kit 2.1

4.3.3.1 For installation, tools (TC21) and (TC22) are required.



Fig. 4.3.3.1

4.3.3.2 Insert tools (TC21) and (TC22) as shown

4.3.3.3 Clean the sealing surface of the actuation piston (15) and the running surface on the compressor. Apply a little motor oil to both the running surface of the compressor and the seal on the actuation piston (15) to ease installation.

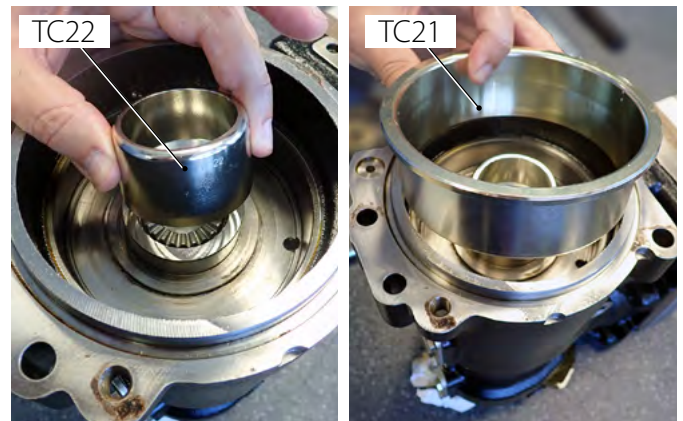

Fig. 4.3.3.2

4.3.3.4 Grease the actuation piston (15) with the lubricant included as shown.



To prevent damage, the actuation piston (15) can only be mounted vertically. Do not tip it.

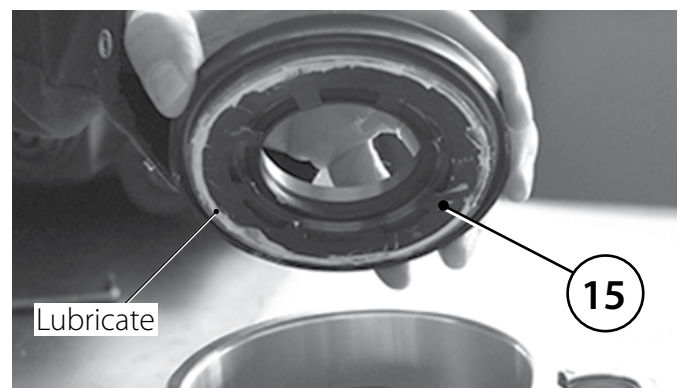

Fig. 4.3.3.4

4 CHECKS AND SERVICING PROCEDURES

4.3.3.5 Carefully mount the actuation piston (15) by hand as far as it will go using the tools (TC21) and (TC22) to guide it into the correct position.



Fig. 4.3.3.5

4.3.3.6 Remove tools (TC21) and (TC22) and then insert the release bearing (14).



Fig. 4.3.3.6

4.3.3.7 Place the Hirth gasket (13) into its dedicated groove in the Hirth connection.

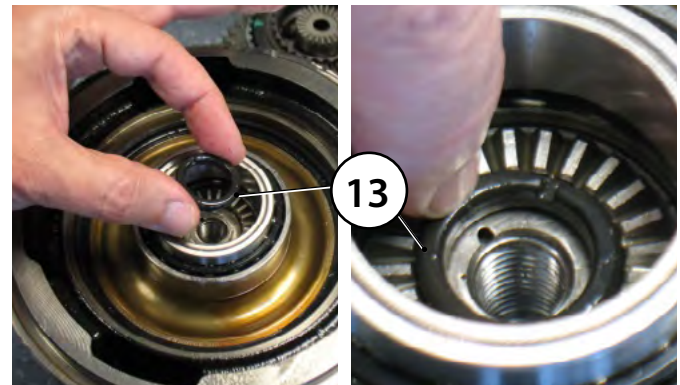

Fig. 4.3.3.7

4.3.3.8 Fit the clutch (13) and hand-press it in so that the Hirth connects with the crankshaft.

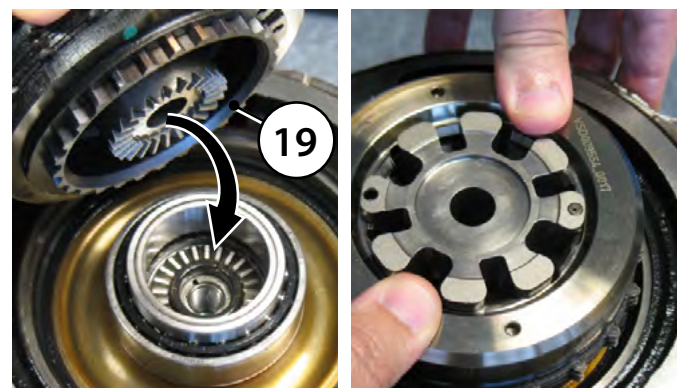

Fig. 4.3.3.8

4.3.3.9 Place the gear and clutch housing (12) onto the clutch (13) as shown.

Note: See Section 4.2.2 for detailed instructions on the correct method of fitment.

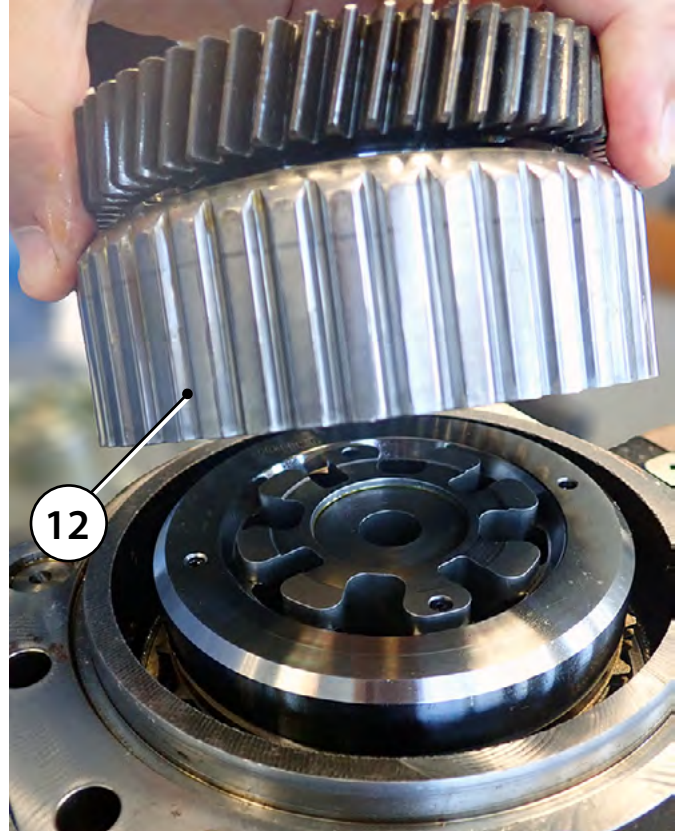

Fig. 4.3.3.9

4.3.3.10 Place the gear support (11) into the gear and clutch housing (12).

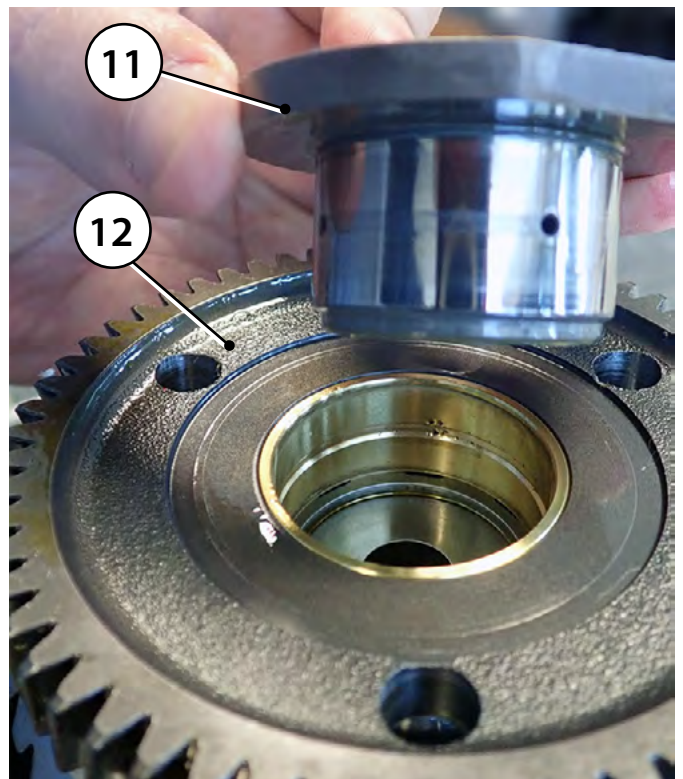

Fig. 4.3.3.10

4 CHECKS AND SERVICING PROCEDURES

4.3.3.11 Place the screw (10) into the gear support (11) and screw it by hand.

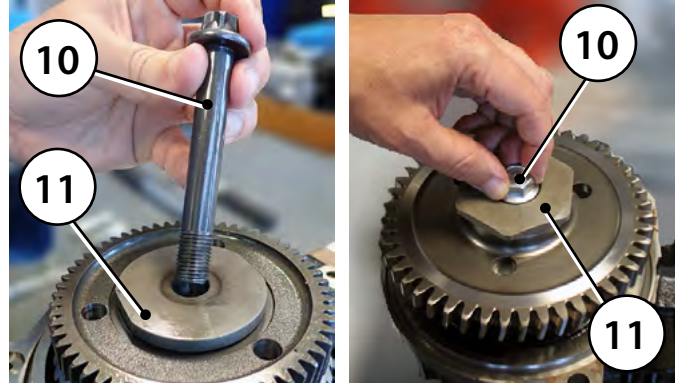

Fig. 4.3.3.12

4.3.3.12 Attach special tool combination (TC13/TC13-2) onto the gear support (11) and tighten fastening bolt (10) according the following sequence:

- M12 version: 70Nm, then untight and tight again to **25Nm + 90°**.
- M14 version: 135Nm, then untight and tight again to **40Nm + 90°**



Fig. 4.3.3.12

4.3.3.13 Remove all tools and check the final dimensions are within the given tolerance.

"l" = 65.35 – 66.15 mm

To mount the complete unit on the engine – see Section 4.2.1.

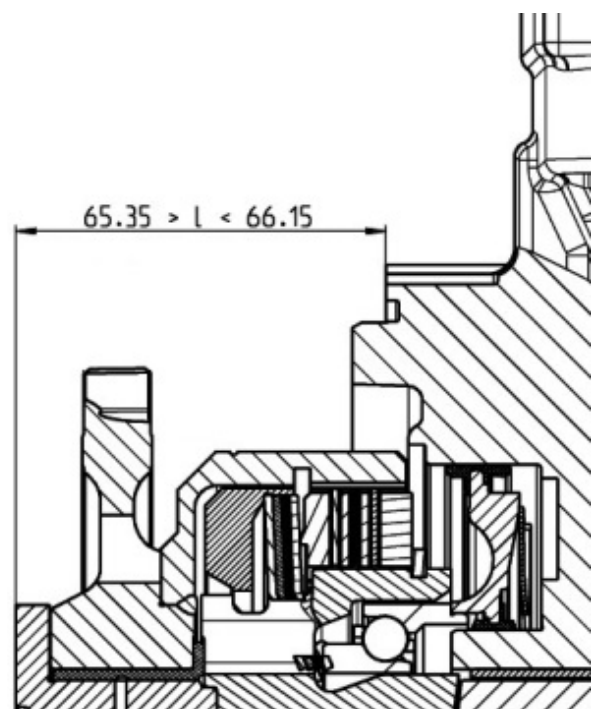

Fig. 4.3.3.13

4.4 Servicing the Valve Plate (8), Cylinder Head (4) and Gaskets – Service Kits 1.1 / 1.2 / 1.4

Depending on the damage, one or more of these service kits will be required – **see Section 2.3:**

- **Service Kit 1.1** (damage to the cylinder head (4) and/or the cooling plate (6))
- **Service Kit 1.2** (damage to the valve plate (8))
- **Service Kit 1.4** (new seals)
- **Service Kit 1.5** (complete cylinder head kit)
See Up2Date Y190309



4.4.1 Removing cylinder head (4) and inlet reeds (9)

4.4.1.1 Undo the six hexagon screws (3) and remove the complete cylinder head (4) as well as the inlet reed (9).



Fig. 4.4.1.1

4 CHECKS AND SERVICING PROCEDURES

4.4.1.2 Remove the two remaining hex screws (2) and remove the upper parts (4+6) from the valve plate (8) and remove the gasket (7)



Fig. 4.4.1.2

4.4.1.3 Separate the cylinder head (4) from the cooling plate (6) and remove the gasket (5)



Fig. 4.4.1.3

4.4.1.4 Replace all the gaskets and components from the required service kit(s).

4.4.1 Assembly of cylinder head (4) and inlet reeds (9)

4.4.1.1 Undo the six hexagon screws (3) and remove the complete cylinder head (4) as well as the inlet reed (9). Clean the surface before to assemble the new inlet reed/gasket.



Fig. 4.4.2.1

4.4.2.2 Mount the new inlet reed (9) and valve plate (8).

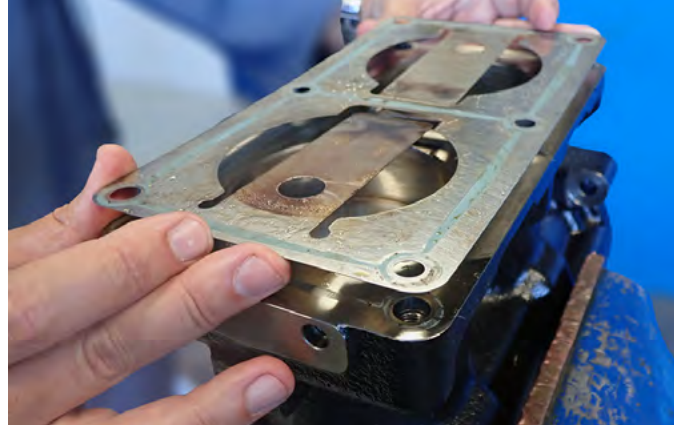

Fig. 4.4.2.2

4.4.2.3 Mount gaskets (7) onto the valve plate (8).



Fig. 4.4.2.3

4 CHECKS AND SERVICING PROCEDURES

4.4.2.4 Mount the cooling plate (6) onto gasket (7).



Fig. 4.4.2.4

4.4.2.5 Mount the second gasket (5) onto cooling plate (6).



Fig. 4.4.2.5

4.4.2.6 Mount the cylinder head (4) onto the cooling plate (6) making sure gasket (5) sits correctly.

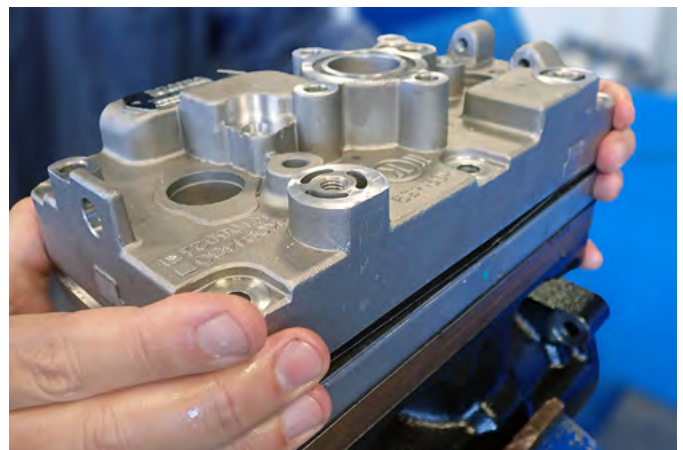

Fig. 4.4.2.6

4.4.2.7 Fix the eight hexagon screws (2 & 3) in accordance to the tightening sequence and torque values - **see Section 2.4**

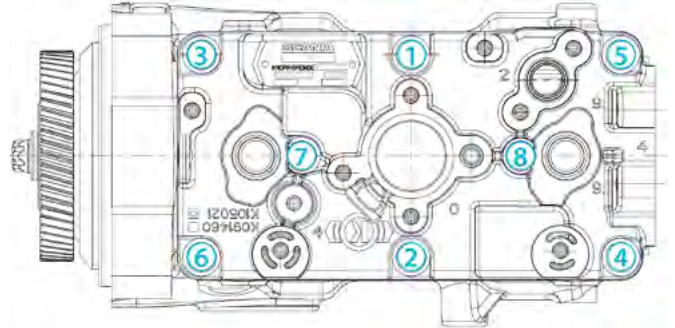

Fig. 4.4.2.

4.5 Leakage Test

Any leakage from the water cooling system can be checked using adapters (TC04-1) and (TC04-2) and a calibrated pressure gauge to carry out a 'pressure drop test'.

Pressurize the water circuit to **5 bar** using an external air supply through the adapter (TC04-1). The air supply can be closed by using tool TC01, allow the pressure to settle then shut off the air supply.

Note: There must be no pressure drop over a period of **60 seconds**.

If a leakage is found, the cylinder head screws may need re-tightening - **see Section 2.4**.

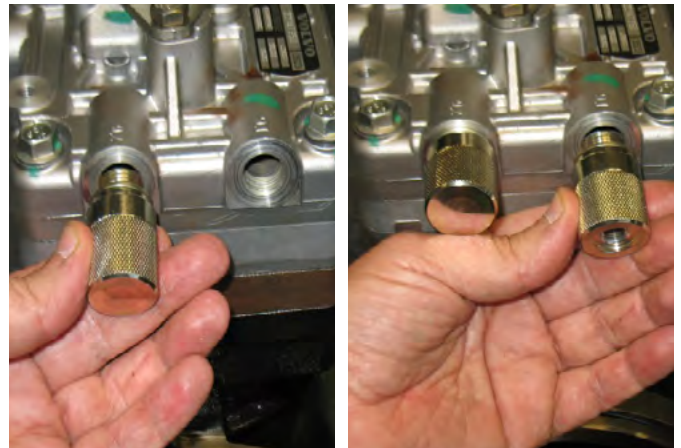

Fig. 4.5

4.6 Gear and Clutch Housing (12) Replacement – Service Kit 2.2

4.6.1 Dismounting the drive gear (12) and the clutch pack (13)

Use the tool **TC13-2**.

4.6.1.1 Whilst holding tool combination **TC13/TC13-2** in position, unscrew the fastening bolt (10) using a suitable torque wrench (18 mm).

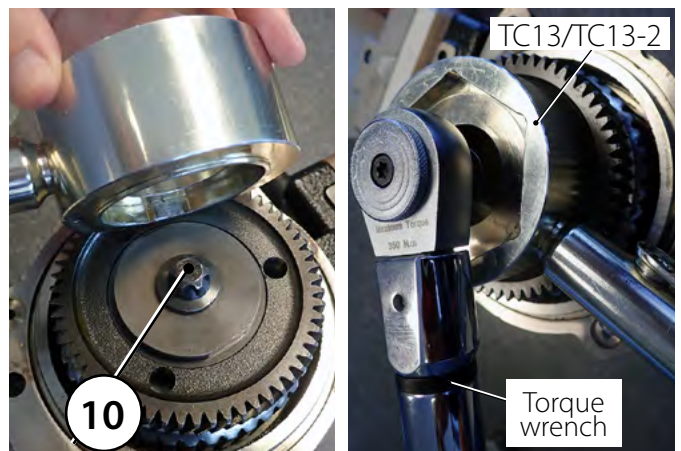

Fig. 4.6.1.1

4 CHECKS AND SERVICING PROCEDURES

4.6.1.2 Remove the clutch pack and gear/drum (12 & 13)

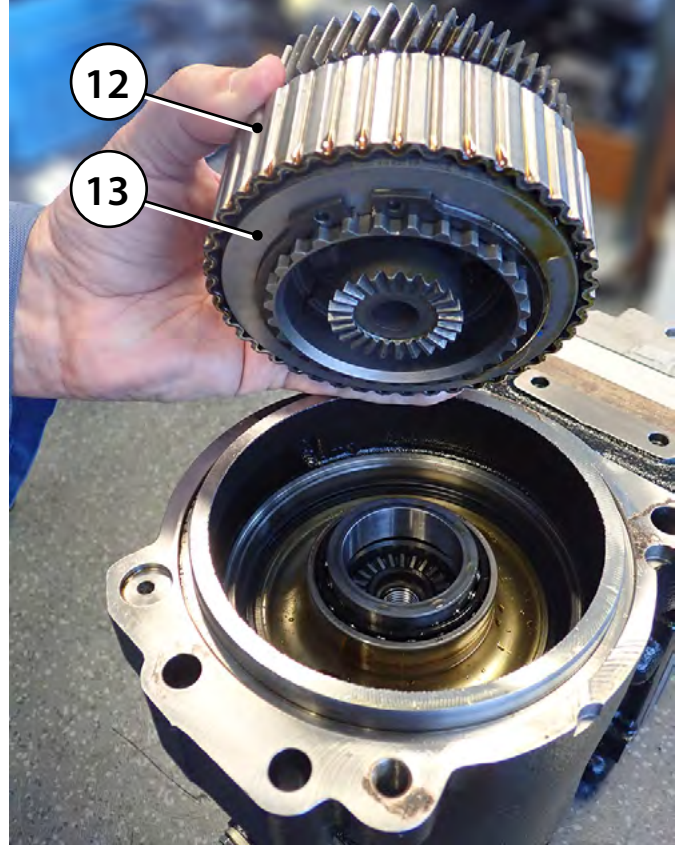

Fig. 4.6.1.2

4.6.1.3 Separate the clutch from its housing, using tool TC14 and a suitable hammer as shown.

The gear and clutch housing (12) can now be exchanged for the new one.

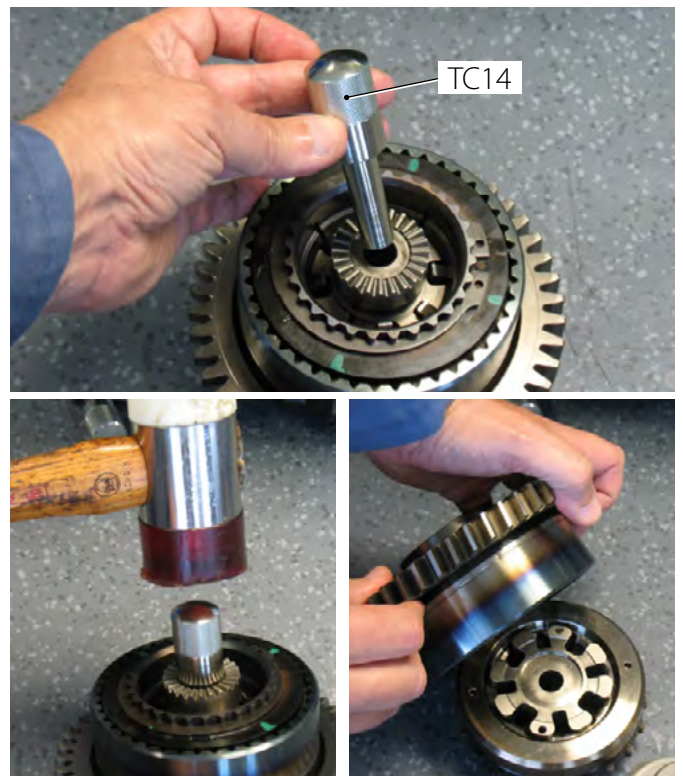

Fig. 4.6.1.3

4.6.1.4 Fit the Hirth gasket (16).

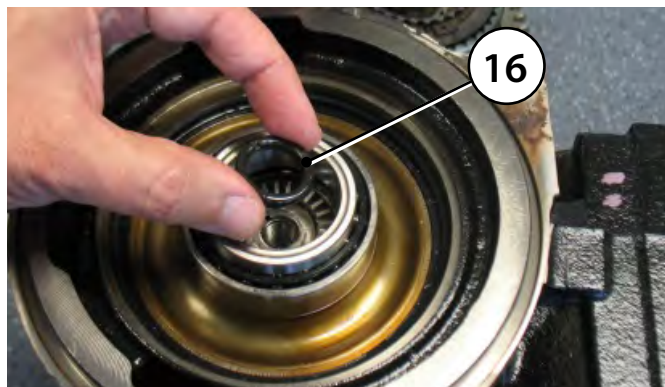

Fig. 4.6.1.4

4.6.1.5 Fit the clutch (13) back in with hand pressure so that the Hirth connects with the crankshaft.

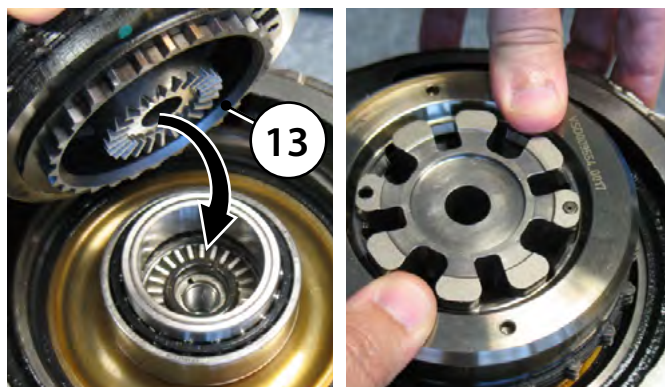

Fig. 4.6.1.5

4.6.1.6 Place the new gear and clutch housing (12) as described in **Section 4.3.3.10**

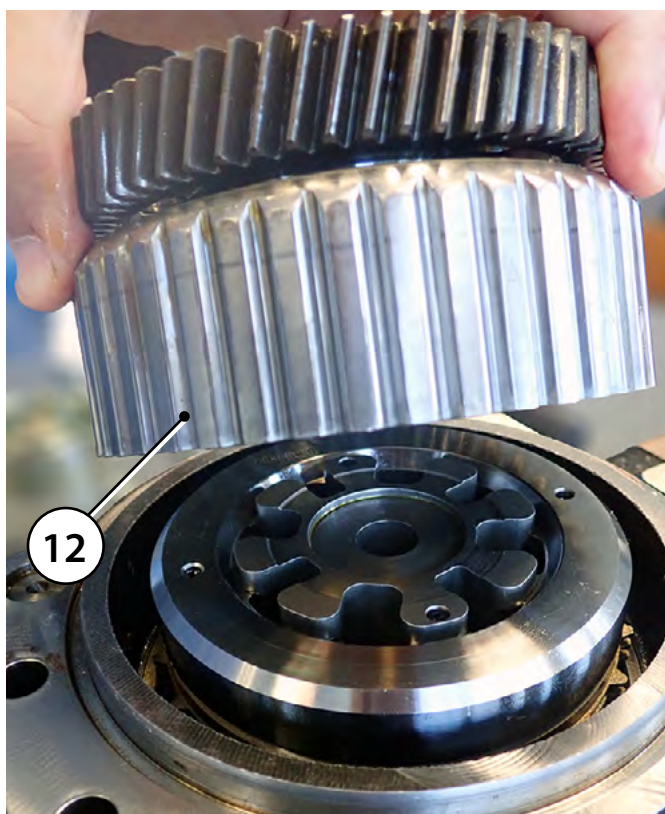

Fig. 4.6.1.6

4 CHECKS AND SERVICING PROCEDURES

4.7 Piston Replacement - Service Kit 1.3

4.7.1 Remove the Cylinder head (4) (**see 4.4**) and the sump covers (19) or caps

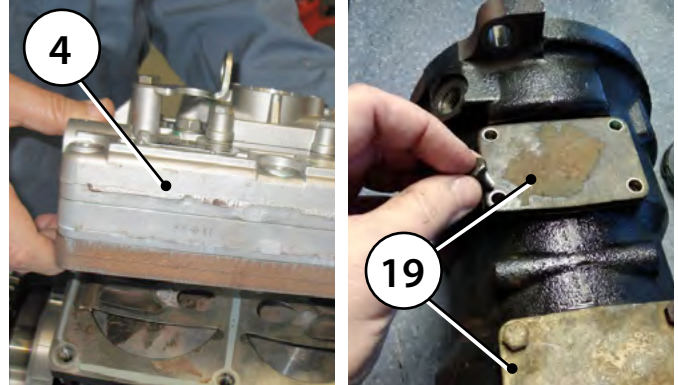

Fig. 4.7.1

4.7.2 Unscrew the con-rods (26). Identify the corresponding cap with each rod for correct re-install later.

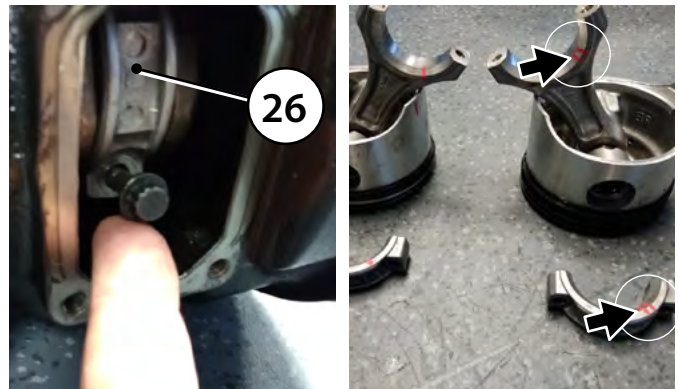

Fig. 4.7.2

4.7.3 Replace the pistons (27) with the new ones supplied in the piston kit.

4.7.4 Re-screw the con-rods (26) to **13-16Nm**.

4.7.5 Replace the sump gaskets (18) with the new ones from the piston kit and re-screw the sump covers (19) with the new screws from the piston kit to **11-13Nm** or caps

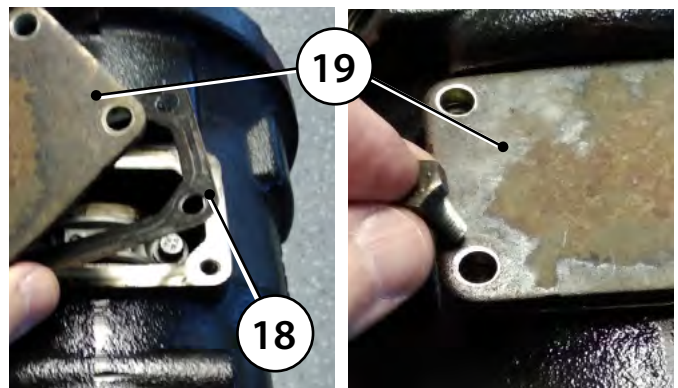

Fig. 4.7.5

4.7.6 Re-assemble the cylinder head (4) with new gaskets (5 & 7) and inlet reed (9) from the piston kit (**see 4.4**).

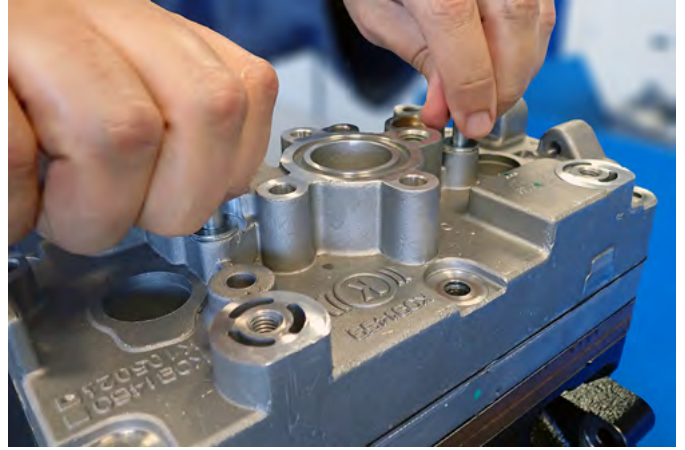

Fig. 4.7.6

Your local **TruckServices Workshops, Dealers and Branches** can be found anytime online at truckservices.knorr-bremse.com.

**Knorr-Bremse Systeme für
Nutzfahrzeuge GmbH**

Moosacher Strasse 80

80809 Munich

Germany

Tel: +49 89 3547-0

Fax: +49 89 3547-2767

truckservices.knorr-bremse.com

