

# *Technical Bulletin*

Bulletin No.: TCH-008-008    Effective Date: 4-1-90    Page: 1 of 11

Subject: **Air Dryer Bypass Systems for High Air Consumption Accessories**

Ref: Schematics (Attached)

The BENDIX AD-2, 3, 4 & 9 air dryers were designed and developed to provide clean, dry air to the vehicle's air brake system. Vehicles employing a high air consumption accessory system, such as bulk trailer unloading, generally cannot meet the minimum operational requirements for a standard air dryer installation. (Reference Bulletin PRO-08-5 or the appropriate service data manual.) While it is possible to install the Bendix air dryer on these vehicles and obtain protection for the brake system only, it is necessary to bypass the air dryer during accessory operation.

Attached are several schematics which illustrate the additional components and piping that are required to bypass the air dryer during operation of the accessory system. Each schematic addresses a particular compressor or system requirement and includes a list of materials as well as a general explanation of features and some installation notes. In all bypass systems the compressor will cycle (load and unload) as required to replace air pressure used in either the brake system or accessory system, however, only air for the brake system supply will pass through the air dryer.

The appropriate bypass system is chosen by determining the compressor make, model, and displacement.

The attached are piping schematics only and are not construction drawings. They are presented here for discussion purposes only; for additional information, consult your Bendix representative.

Before choosing one of the bypass systems presented, make certain that it fills the requirements.



# Air Dryer By-Pass System for 17 CFM Max. Output Compressors

**Important:** See backside for installation precautions and features

Air Connections	
C	= Control
S	= Supply air
D	= Delivery

Note 1 - This component is not available from Bendix.  
 Note 2 - Reference 065041 AD-4 or 065225 AD-9.  
 Exact Pc. No. dependant on pipe thread requirements.  
 AD-4 and AD-9 may be used interchangeably.

List of Materials				
Item	Qty	Model	Part No.	Description
1	1	D-2	275491	Air compressor 17 C.F.M. max. delivered output
2	1	TR-3	101450	Governor (100 psi cut-in 120 psi cut-out)
3	2	AD-4/9	Note 2	Inversion valve (gov. & park synchronizer)
4	1	TW-2	280905	Bendix air dryer
5	1	..	..	Dash control (accessory or brake selector)
6	1	..	..	Reservoir
7	1	..	..	Reservoir drain cock
8	1	..	..	Water trap filter
9	1	SC-1	Note 1	Single check valve
10	1	R-12	..	Relay valve
11	1	..	Note 1	HIGH CAP. press. regulator
12	1	..	Note 1	HIGH CAP. safety valve
13	1	..	Note 1	Self-sealing coupling
14	1	ST-3	..	Safety valve
15	1	DC-4	..	Double check valve

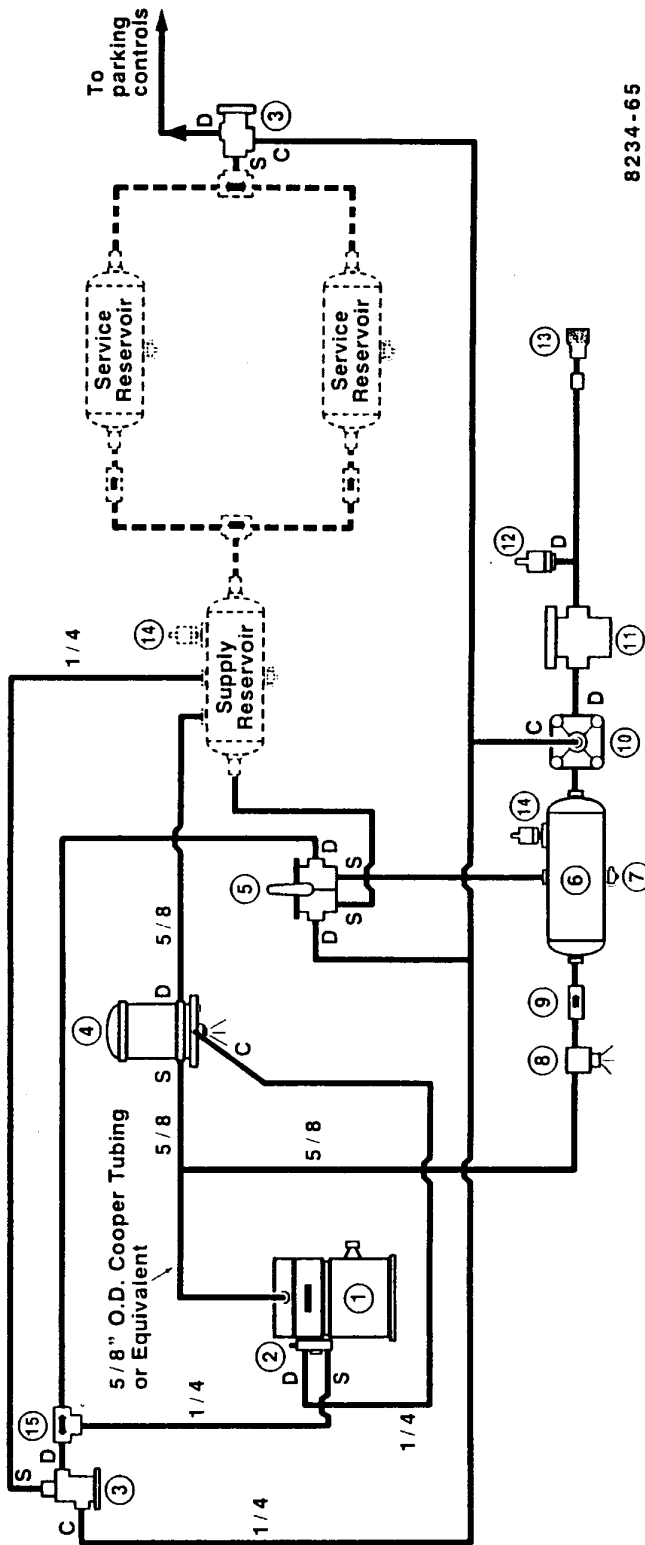

## INSTALLATION PRECAUTIONS AND SYSTEM FEATURES

1. This is a piping schematic only and is not a construction drawing. The schematic presented here is for discussion purposes only; for additional information consult your Bendix representative.
2. All tubing shown is 3/8" O.D. unless otherwise specified. When nylon tubing is installed, inserts must be used. Nylon tubing must not be used where temperatures exceed 180 degrees F.
3. When the vehicle's air compressor is used to provide compressed air to a high air usage accessory system or for bulk trailer unloading, the air dryer must be by-passed as shown on this schematic. The air dryers in this schematic will provide dry air to the brake system only, and not to the accessory or bulk trailer unloading system. Use of the air dryer for high air usage accessory systems will result in wet air delivery and possible air dryer damage.
4. This plumbing arrangement is recommended for compressors with a maximum delivered output of 17 to 34 cubic feet per minute at 120 psi head pressure and MAY BE USED IN LIEU ANY SINGLE AIR DRYER SYSTEM. Bendix compressors in this category are; TuFlo 1000 and 1400. The recommended system parameters presented here must be adhered to.
5. This system:
  - A. Provides manual selection and use of either the air brake system or accessory system (control valve item 6).
  - B. Provides automatic application of the tractor parking brakes during accessory system use (second TR-3 valve item 3).
  - C. Provides shut-off of accessory system air when vehicle is engaged in highway operation (relay valve item 10).
6. In order to insure equal flow through both air dryers, it is recommended that the two input and two output lines at the air dryer be uniform in length and be routed to eliminate bends, - restrictions, etc..

# Air Dryer By-Pass System for Bendix TuFlo 1400 Compressor

**Important: See backside for installation precautions and features**

Air Connections	
C	= Control
S	= Supply air
D	= Delivery

Note 1 - This component is not available from Bendix.  
 Note 2 - Reference 065041 AD-4 or 065225 AD-9.  
 Exact Pc. No. dependant on pipe thread requirements.  
 AD-4 and AD-9 may be used interchangeably.

List of Materials				
Item	Qty	Model	Part No.	Description
1	1	TF1400	--	Bendix TuFlo 1400 31 C.F.M. displacement Governor (100 psi cut-in 120 psi cut-out)
2	1	D-2	275491	Inversion valve (gov. & park synchronizer)
3	2	TR-3	101450	Bendix air dryer
4	4	AD-4/9	Note 2	Dash control (accessory or brake selector)
5	1	TW-2	280905	Reservoir
6	1	--	--	Reservoir drain cock
7	1	--	--	Water trap filter
8	1	--	--	Single check valve
9	1	SC-1	Note 1	Relay valve
10	1	R-12	--	HIGH CAP. press. regulator
11	1	--	Note 1	HIGH CAP. safety valve
12	1	--	Note 1	Self-sealing coupling
13	1	--	--	Safety valve
14	1	ST-3	--	Double check valve
15	1	DC-4	--	Governor (70 psi cut-in 85 psi cut-out)
16	1	D-2	283277	Governor (70 psi cut-in 85 psi cut-out)

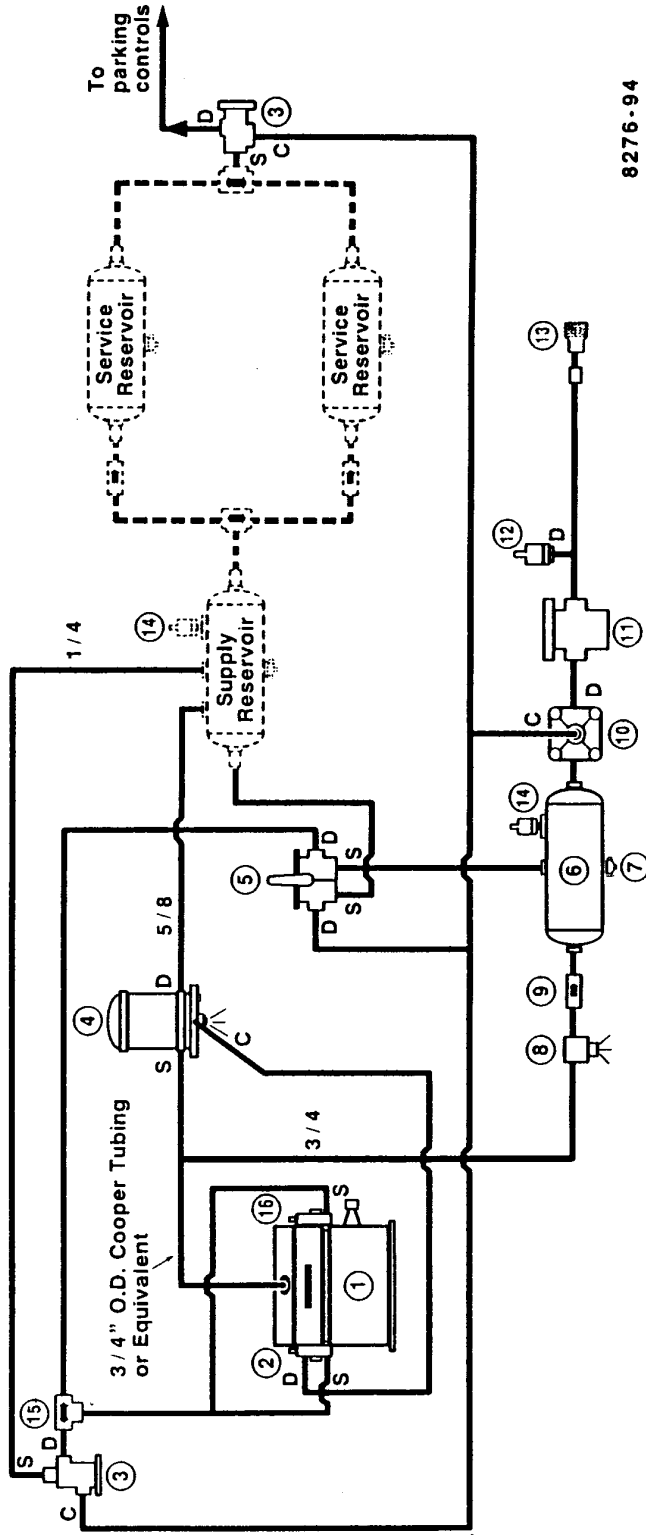

## INSTALLATION PRECAUTIONS AND SYSTEM FEATURES

1. This is a piping schematic only and is not a construction drawing. The schematic presented here is for discussion purposes only; for additional information consult your Bendix representative.
2. All tubing shown is 3/8" O.D. unless otherwise specified. When nylon tubing is installed, inserts must be used. Nylon tubing must not be used where temperatures exceed 180 degrees F.
3. When the vehicle's air compressor is used to provide compressed air to a high air usage accessory system or for bulk trailer unloading, the air dryer must be by-passed as shown on this schematic. The air dryer in this schematic will provide dry air to the brake system only, and not to the accessory or bulk trailer unloading system. Use of the air dryer for high air usage accessory systems will result in wet air delivery and possible air dryer damage.
4. This plumbing arrangement is presented specifically for the Bendix Tu Flo 1400 compressor when used for bulk tank trailer charging. The recommended system parameters presented here must be adhered to.
5. This system:
  - A. Provides manual selection and use of either the air brake system or accessory system (control valve item 6).
  - B. Provides automatic application of the tractor parking brakes during accessory system use (second TR-3 valve item 3).
  - C. Provides shut-off of accessory system air when vehicle is engaged in highway operation (relay valve item 10).
  - D. Utilizes twin governors which individually control the front and rear pair of cylinders in the TuFlo 1400 compressor. During normal brake system operation only the front or drive end pair of cylinders provide air to the brake system. During accessory system operation all four cylinders are capable of providing air for bulk trailer unloading.
6. As an alternative to this system, refer to the bypass system presented on sa830215.

# Air Dryer By-Pass System for Holset (Cummins) 30 CFM Compressor

**Important: See backside for installation precautions and features**

Air Connections	
C	= Control
S	= Supply air
D	= Delivery

Note 1 - This component is not available from Bendix.  
 Note 2 - Reference 065041 AD-4 or 065225 AD-9.  
 Exact Pc. No. dependant on pipe thread requirements.  
 AD-4 and AD-9 may be used interchangeably.

List of Materials				
Item	Qty	Model	Part No.	Description
1	1	D-2	275491	Air compressor 17 C.F.M. max. delivered output Governor (100 psi cut-in 120 psi cut-out)
2	1	TR-3	101450	Inversion valve (gov. & park synchronizer)
3	2	AD-4/9	Note 2	Bendix air dryer with extended purge
4	1	TW-2	280905	Dash control (accessory or brake selector)
5	1	..	..	Reservoir
6	1	..	..	Reservoir drain cock
7	1	..	..	Water trap filter
8	1	SC-1	Note 1	Single check valve
9	1	R-12	..	Relay valve
10	1	..	Note 1	HIGH CAP. press. regulator
11	1	..	Note 1	HIGH CAP. safety valve
12	1	..	Note 1	Self-sealing coupling
13	1	ST-3	..	Safety valve
14	1	DC-4	..	Double check valve
15	1	..	..	..

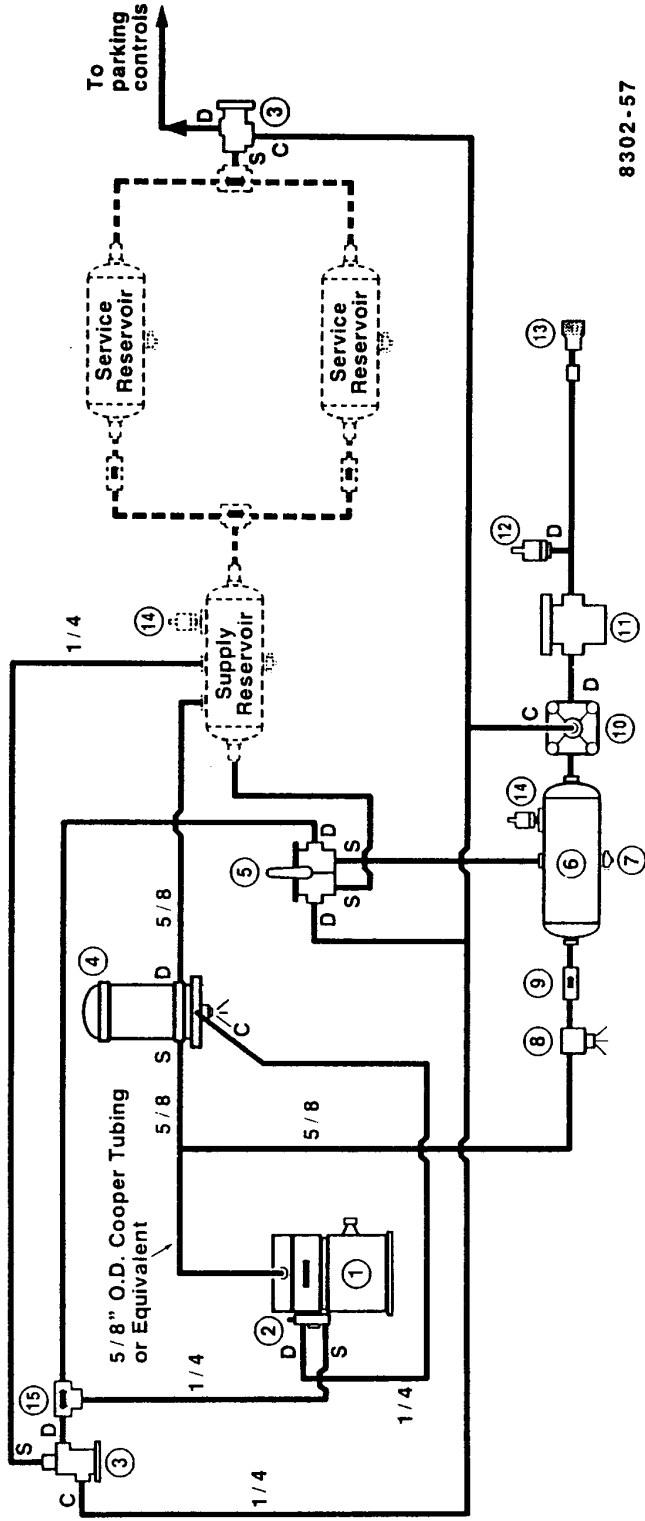

## INSTALLATION PRECAUTIONS AND SYSTEM FEATURES

1. This is a piping schematic only and is not a construction drawing. The schematic presented here is for discussion purposes only; for additional information consult your Bendix representative.
2. All tubing shown is 3/8" O.D. unless otherwise specified. When nylon tubing is installed, inserts must be used. Nylon tubing must not be used where temperatures exceed 180 degrees F.
3. When the vehicle's air compressor is used to provide compressed air to a high air usage accessory system or for bulk trailer unloading, the air dryer must be by-passed as shown on this schematic. The air dryer in this schematic will provide dry air to the brake system only, and not to the accessory or bulk trailer unloading system. Use of the air dryer for high air usage accessory systems will result in wet air delivery and possible air dryer damage.
4. This plumbing arrangement is recommended for the Holset (Cummins) 30 cubic foot per minute compressor and bulk tank trailer charging. The recommended system parameters presented here must be adhered to.
  - A. The Bendix air dryer used in conjunction with the Cummins/Holset compressor must incorporate the extended purge volume.
  - B. The maximum air brake system reservoir volume must not exceed 15,000 cubic inches.
  - C. A minimum of 14 feet of discharge line must be used between the compressor and air dryer.
5. This system:
  - A. Provides manual selection and use of either the air brake system or accessory system (control valve item 6).
  - B. Provides automatic application of the tractor parking brakes during accessory system use (second TR-3 valve item 3).
  - C. Provides shut-off of accessory system air when vehicle is engaged in highway operation (relay valve item 10).

LIST OF MATERIAL TO PROVIDE SUBJECT FEATURE

ITEM NO.	QTY.	MODEL	OEM PIECE NO.	SERVICE PIECE NO.	DESCRIPTION
1	1	PR-3	101275	---	PRESSURE PROTECTION VALVE (70 PSI)
2	1	---	---	---	PING TANK (TYPICAL 37" x 18")
3	1	RV-1	279926	---	PRESSURE REDUCING VALVE (40 PSI)
4	1	TW-1	281825	---	TWO-WAY CONTROL VALVE
5	1	OR-1	282411	---	QUICK RELEASE VALVE
6	1	ST-1	280367	---	SAFETY VALVE (50/60 PSI SETTING)
7	1	---	---	---	LOW PRESSURE ACCESSORY RESERVOIR
8	1	---	---	---	DRAIN COCK
9	1	SV-1	283700	---	SYNCHRONIZING VALVE

PORT	LEGEND
C	- CONTROL
D	- DELIVERY
EM	- EMERGENCY
SR	- SERVICE
S	- SUPPLY RESERVOIR

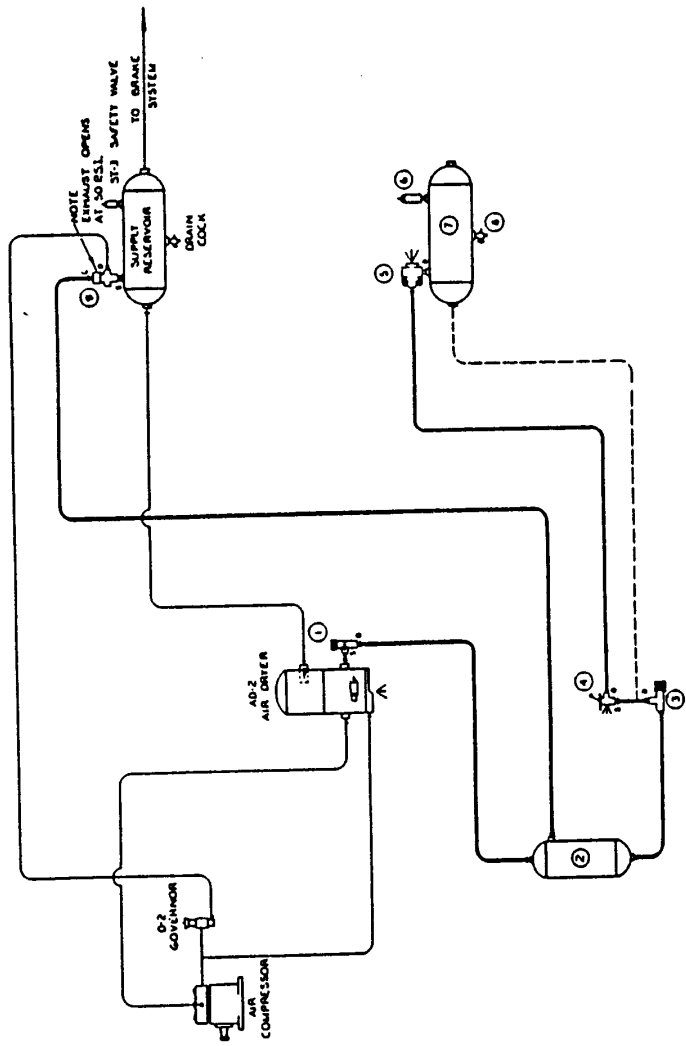



## LOW PRESSURE ACCESSORY SUPPLY SOURCE

### Features:

1. Accessory air is not dried.
2. Governor is controlled by brake system and accessory system.
3. Accessory supply pressure is adjustable.

### Notes:

1. This is a partial system.
2. QR-1 and TW-1 is for manual control of low pressure accessory reservoir.
3. Mount ping tank (Item 2) as shown.

—— Low Pressure Circuit

—— Air Brake Circuit

----- For Accessories Not Requiring A Manual Control

# Air Dryer By-Pass System for 17-34 CFM Max. Output Compressors

**Important: See backside for installation precautions and features**

Air Connections	
C	= Control
S	= Supply air
D	= Delivery

Note 1 - This component is not available from Bendix.  
 Note 2 - Reference 065041 AD-4 or 065225 AD-9.  
 Exact Pc. No. dependant on pipe thread requirements.  
 Either 2 AD-4's or 2 AD-9's may be used.

List of Materials				
Item	Qty	Model	Part No.	Description
1	1	D-2	275491	Air compressor 17 to 34 C.F.M. displacement
2	1	TR-3	101450	Governor (100 psi cut-in 120 psi cut-out)
3	2	AD-4/9	Note 2	Inversion valve (gov. & park synchronizer)
4	2	TW-2	280905	Bendix air dryer
5	1	..	..	Dash control (accessory or brake selector)
6	1	..	..	Reservoir
7	1	..	..	Reservoir drain cock
8	1	..	..	Water trap filter
9	1	SC-1	Note 1	Single check valve
10	1	R-12	..	Relay valve
11	1	..	Note 1	HIGH CAP. press. regulator
12	1	..	Note 1	HIGH CAP. safety valve
13	1	..	Note 1	Self-sealing coupling
14	1	ST-3	..	Safety valve
15	1	DC-4	..	Double check valve

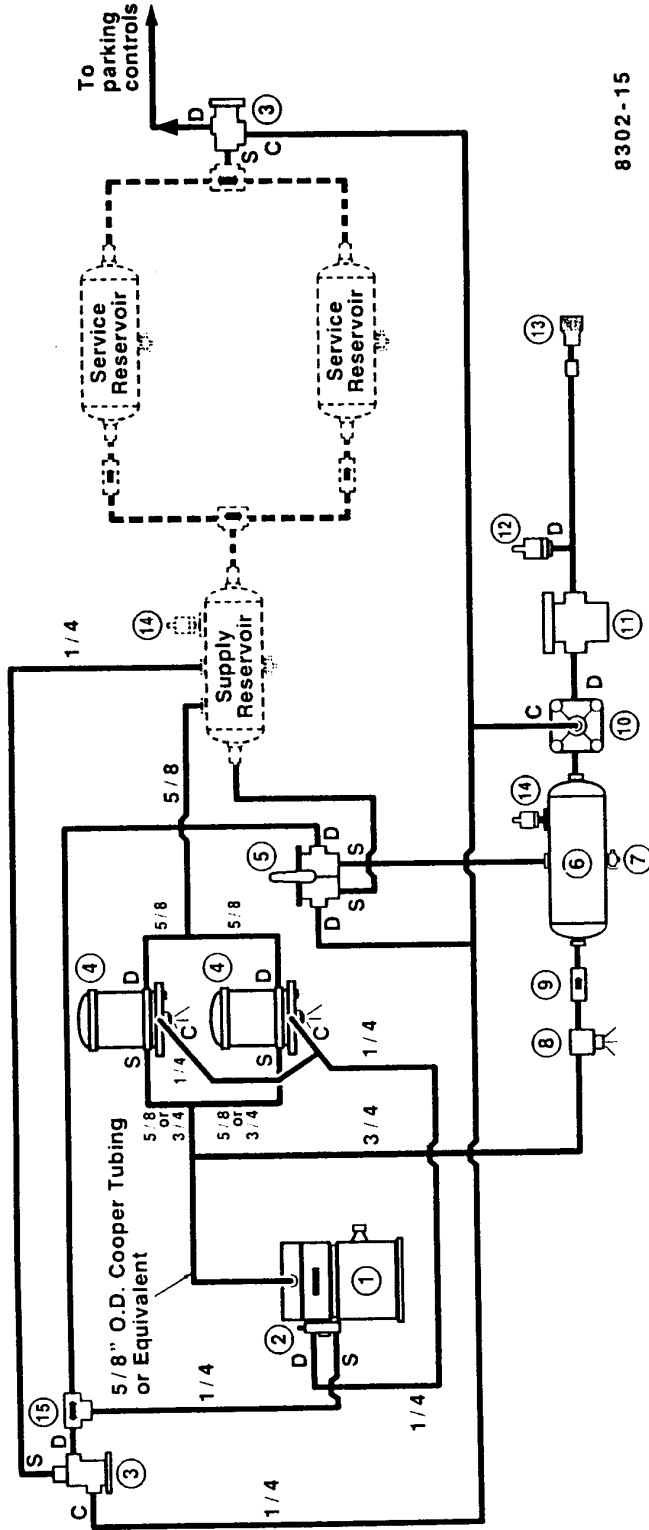

8302-15

## INSTALLATION PRECAUTIONS AND SYSTEM FEATURES

1. This is a piping schematic only and is not a construction drawing. The schematic presented here is for discussion purposes only; for additional information consult your Bendix representative.
2. All tubing shown is 3/8" O.D. unless otherwise specified. When nylon tubing is installed, inserts must be used. Nylon tubing must not be used where temperatures exceed 180 degrees F.
3. When the vehicle's air compressor is used to provide compressed air to a high air usage accessory system or for bulk trailer unloading, the air dryer must be by-passed as shown on this schematic. The air dryers in this schematic will provide dry air to the brake system only, and not to the accessory or bulk trailer unloading system. Use of the air dryer for high air usage accessory systems will result in wet air delivery and possible air dryer damage.
4. This plumbing arrangement is recommended for compressors with a maximum delivered output of 17 to 34 cubic feet per minute at 120 psi head pressure and MAY BE USED IN LIEU ANY SINGLE AIR DRYER SYSTEM. Bendix compressors in this category are; TuFlo 1000 and 1400. The recommended system parameters presented here must be adhered to.
5. This system:
  - A. Provides manual selection and use of either the air brake system or accessory system (control valve item 6).
  - B. Provides automatic application of the tractor parking brakes during accessory system use (second TR-3 valve item 3).
  - C. Provides shut-off of accessory system air when vehicle is engaged in highway operation (relay valve item 10).
6. In order to insure equal flow through both air dryers, it is recommended that the two input and two output lines at the air dryer be uniform in length and be routed to eliminate bends, restrictions, etc..

