

# Installation Instructions

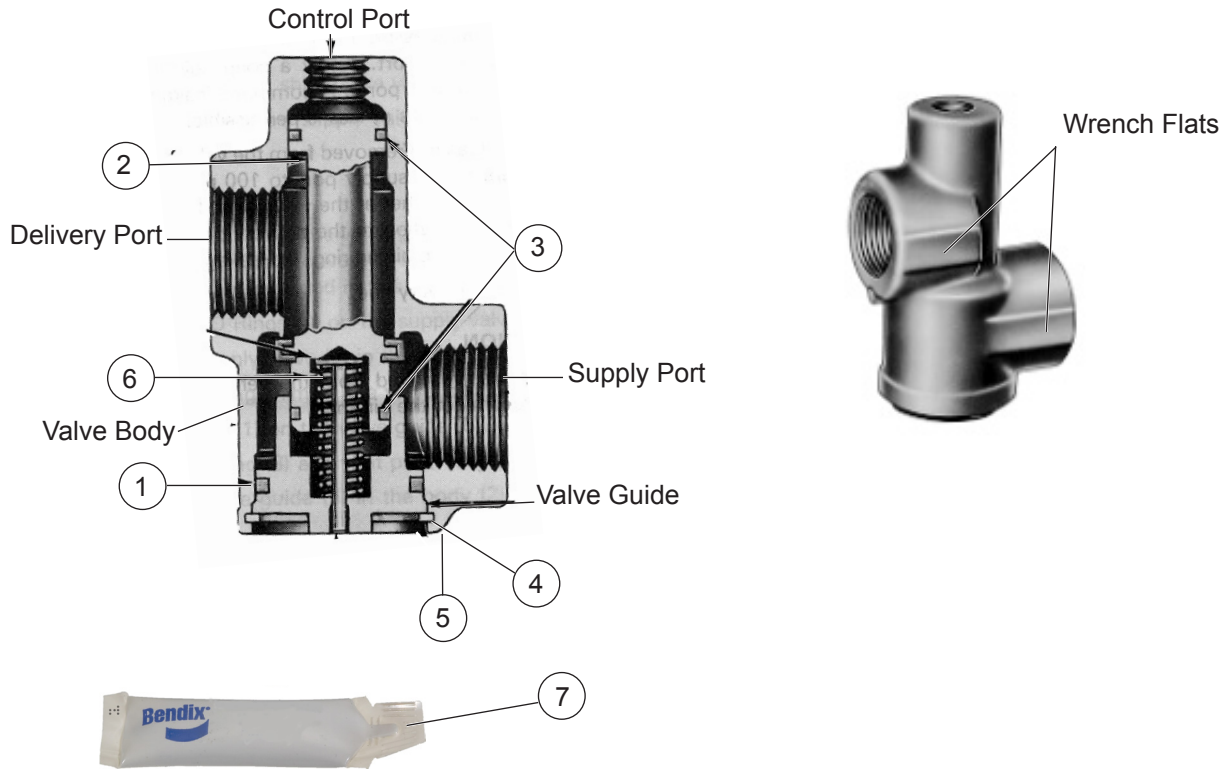

## BENDIX® AS-2 AIR STARTER VALVE FIELD MAINTENANCE KIT



Kit Contents		
Item No.	Description	Qty.
1	O-Ring	1
2	Supply Valve	1
3	O-Ring	2
4	Retaining Ring	1
5	Boot (Not Shown)	1
6*	Spring	2
7	Tube of Lubricant	1

**\*NOTE:** Two springs are included with this kit in order that all AS-2 valves can be serviced. One spring will be used and the other discarded. The springs differ by approximately one quarter inch (1/4") in free height. The spring removed during disassembly should be compared to each of the new springs to determine which new spring to use.

Figure 1 – Bendix® AS-2 Air Starter Valve Field Maintenance Kit Contents

## GENERAL SAFETY GUIDELINES



**WARNING! PLEASE READ AND FOLLOW THESE INSTRUCTIONS**



**TO AVOID PERSONAL INJURY OR DEATH:**

When working on or around a vehicle, the following guidelines should be observed **AT ALL TIMES**:

- ▲ Park the vehicle on a level surface, apply the parking brakes and always block the wheels. Always wear personal protection equipment.
- ▲ Stop the engine and remove the ignition key when working under or around the vehicle. When working in the engine compartment, the engine should be shut off and the ignition key should be removed. Where circumstances require that the engine be in operation, **EXTREME CAUTION** should be used to prevent personal injury resulting from contact with moving, rotating, leaking, heated or electrically-charged components.
- ▲ Do not attempt to install, remove, disassemble or assemble a component until you have read, and thoroughly understand, the recommended procedures. Use only the proper tools and observe all precautions pertaining to use of those tools.
- ▲ If the work is being performed on the vehicle's air brake system, or any auxiliary pressurized air systems, make certain to drain the air pressure from all reservoirs before beginning ANY work on the vehicle. If the vehicle is equipped with a Bendix® AD-IS® air dryer system, a Bendix® DRM™ dryer reservoir module, or a Bendix® AD-9si® air dryer, be sure to drain the purge reservoir.
- ▲ Following the vehicle manufacturer's recommended procedures, deactivate the electrical system in a manner that safely removes all electrical power from the vehicle.
- ▲ Never exceed manufacturer's recommended pressures.
- ▲ You should consult the vehicle manufacturer's operating and service manuals, and any related literature, in conjunction with the Guidelines above.
- ▲ Never connect or disconnect a hose or line containing pressure; it may whip and/or cause hazardous airborne dust and dirt particles. Wear eye protection. Slowly open connections with care, and verify that no pressure is present. Never remove a component or plug unless you are certain all system pressure has been depleted.
- ▲ Use only genuine Bendix® brand replacement parts, components and kits. Replacement hardware, tubing, hose, fittings, wiring, etc. must be of equivalent size, type and strength as original equipment and be designed specifically for such applications and systems.
- ▲ Components with stripped threads or damaged parts should be replaced rather than repaired. Do not attempt repairs requiring machining or welding unless specifically stated and approved by the vehicle and component manufacturer.
- ▲ Prior to returning the vehicle to service, make certain all components and systems are restored to their proper operating condition.
- ▲ For vehicles with Automatic Traction Control (ATC), the ATC function must be disabled (ATC indicator lamp should be ON) prior to performing any vehicle maintenance where one or more wheels on a drive axle are lifted off the ground and moving.
- ▲ The power **MUST** be temporarily disconnected from the radar sensor whenever any tests **USING A DYNAMOMETER** are conducted on a vehicle equipped with a Bendix® Wingman® system.

## REMOVAL

**NOTE:** Depending upon installation, we recommend that the air starter valve be serviced without removing from the reservoir. In installations where complete valve removal is necessary, caution should be used so as not to damage the valve body during removal.

1. Park the vehicle by means other than the air brakes on a level surface.
2. Drain the air pressure from all reservoirs.
3. If the valve is to be removed, identify air lines and disconnect and remove the valve.

## DISASSEMBLY

1. Remove and discard the boot (5).
2. While holding the valve guide, remove and discard the retaining ring (4).
3. Remove the valve guide from the valve body.
4. Remove and discard the o-ring (1) from the valve guide.
5. Remove and discard the spring (6).
6. Remove and discard the supply valve (2) and its o-rings (3).

## ASSEMBLY

Prior to assembly, clean the valve guide and valve body. Lubricate the o-ring grooves, o-rings and body bores using the lubricant (7) in this kit.

1. Install both o-rings (3) on the supply valve (2).
2. Install the o-ring (1) on the valve guide.
3. Install the supply valve (2) in the valve body.
4. Install the spring (6) in the supply valve (2).
5. Install the valve guide in the valve body.
6. Install the retaining ring (4) in the body, making sure it is completely seated in its groove.
7. Install the boot (5) on the valve guide.

## LEAKAGE TEST

1. If the valve has been removed from the vehicle, apply a source of air pressure (120 psi) to the supply port. Apply a soap solution to the delivery port, the vent pin area, and around the retaining ring. No leakage is permitted.
2. Exhaust the air pressure from the supply port and apply it to the control port. Apply a soap solution to the supply and delivery ports. A combined leakage rate of a 1" bubble in 3 seconds or less is permissible.
3. If the valve was not removed from the vehicle, build the air pressure at the supply port to 100 psi and remove the delivery line either at the valve or at the air starter. Apply a soap solution to the delivery port and around the vent pin and retaining ring. No leakage is permitted.
4. Reinstall the delivery line.

## INSTALLATION

If the valve was removed from the vehicle, reinstall the valve and reconnect the air lines.

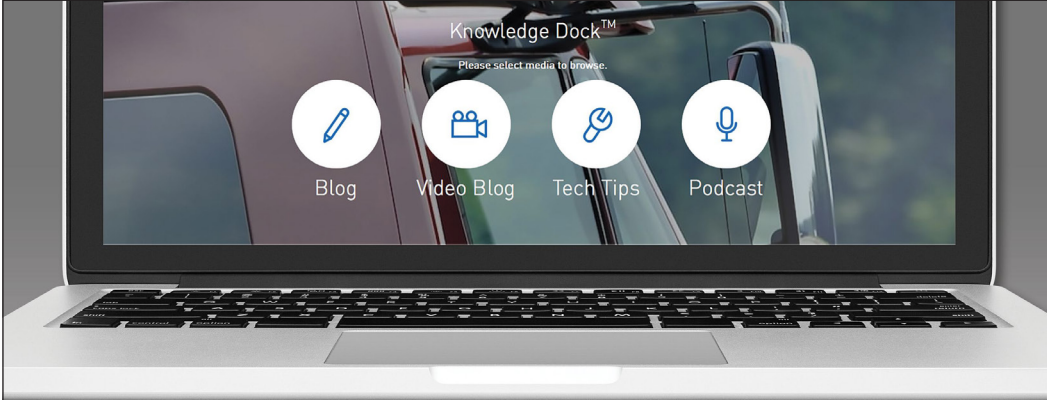

**Trucking moves fast. Move faster.**  
**Knowledge Dock™**  
• BLOGS • PODCASTS • VIDEOS • 24/7/365  
[ [knowledge-dock.com](http://knowledge-dock.com) ]



**Log-on and Learn from the Best**  
On-line training that's available when you are – 24/7/365.  
Visit [brake-school.com](http://brake-school.com).