

Installation Instructions

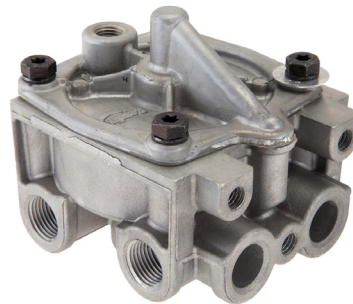

BENDIX® R-12P™ PILOT RELAY VALVE

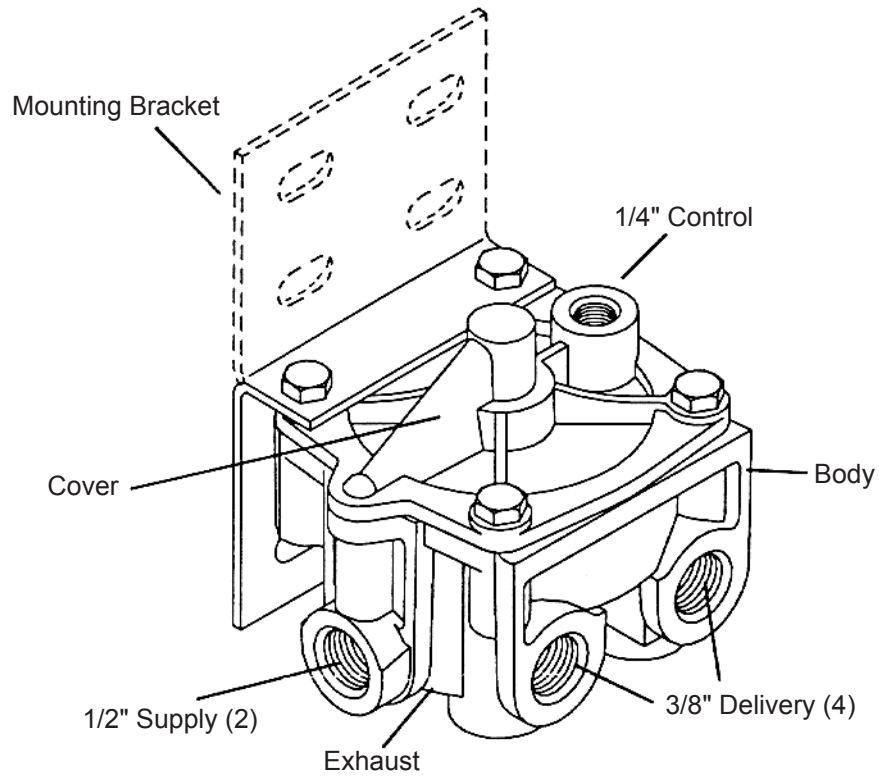

**Bendix® R-12P™ Pilot
Relay Valve**

Figure 1 – Bendix® R-12P™ Pilot Relay Valve

GENERAL SAFETY GUIDELINES



WARNING! PLEASE READ AND FOLLOW THESE INSTRUCTIONS



TO AVOID PERSONAL INJURY OR DEATH:

When working on or around a vehicle, the following guidelines should be observed **AT ALL TIMES**:

- ▲ Park the vehicle on a level surface, apply the parking brakes and always block the wheels. Always wear personal protection equipment.
- ▲ Stop the engine and remove the ignition key when working under or around the vehicle. When working in the engine compartment, the engine should be shut off and the ignition key should be removed. Where circumstances require that the engine be in operation, **EXTREME CAUTION** should be used to prevent personal injury resulting from contact with moving, rotating, leaking, heated or electrically-charged components.
- ▲ Do not attempt to install, remove, disassemble or assemble a component until you have read, and thoroughly understand, the recommended procedures. Use only the proper tools and observe all precautions pertaining to use of those tools.
- ▲ If the work is being performed on the vehicle's air brake system, or any auxiliary pressurized air systems, make certain to drain the air pressure from all reservoirs before beginning ANY work on the vehicle. If the vehicle is equipped with a Bendix® AD-IS® air dryer system, a Bendix® DRM™ dryer reservoir module, or a Bendix® AD-9si® air dryer, be sure to drain the purge reservoir.
- ▲ Following the vehicle manufacturer's recommended procedures, deactivate the electrical system in a manner that safely removes all electrical power from the vehicle.
- ▲ Never exceed manufacturer's recommended pressures.
- ▲ You should consult the vehicle manufacturer's operating and service manuals, and any related literature, in conjunction with the Guidelines above.
- ▲ Never connect or disconnect a hose or line containing pressure; it may whip and/or cause hazardous airborne dust and dirt particles. Wear eye protection. Slowly open connections with care, and verify that no pressure is present. Never remove a component or plug unless you are certain all system pressure has been depleted.
- ▲ Use only genuine Bendix® brand replacement parts, components and kits. Replacement hardware, tubing, hose, fittings, wiring, etc. must be of equivalent size, type and strength as original equipment and be designed specifically for such applications and systems.
- ▲ Components with stripped threads or damaged parts should be replaced rather than repaired. Do not attempt repairs requiring machining or welding unless specifically stated and approved by the vehicle and component manufacturer.
- ▲ Prior to returning the vehicle to service, make certain all components and systems are restored to their proper operating condition.
- ▲ For vehicles with Automatic Traction Control (ATC), the ATC function must be disabled (ATC indicator lamp should be ON) prior to performing any vehicle maintenance where one or more wheels on a drive axle are lifted off the ground and moving.
- ▲ The power **MUST** be temporarily disconnected from the radar sensor whenever any tests **USING A DYNAMOMETER** are conducted on a vehicle equipped with a Bendix® Wingman® system.

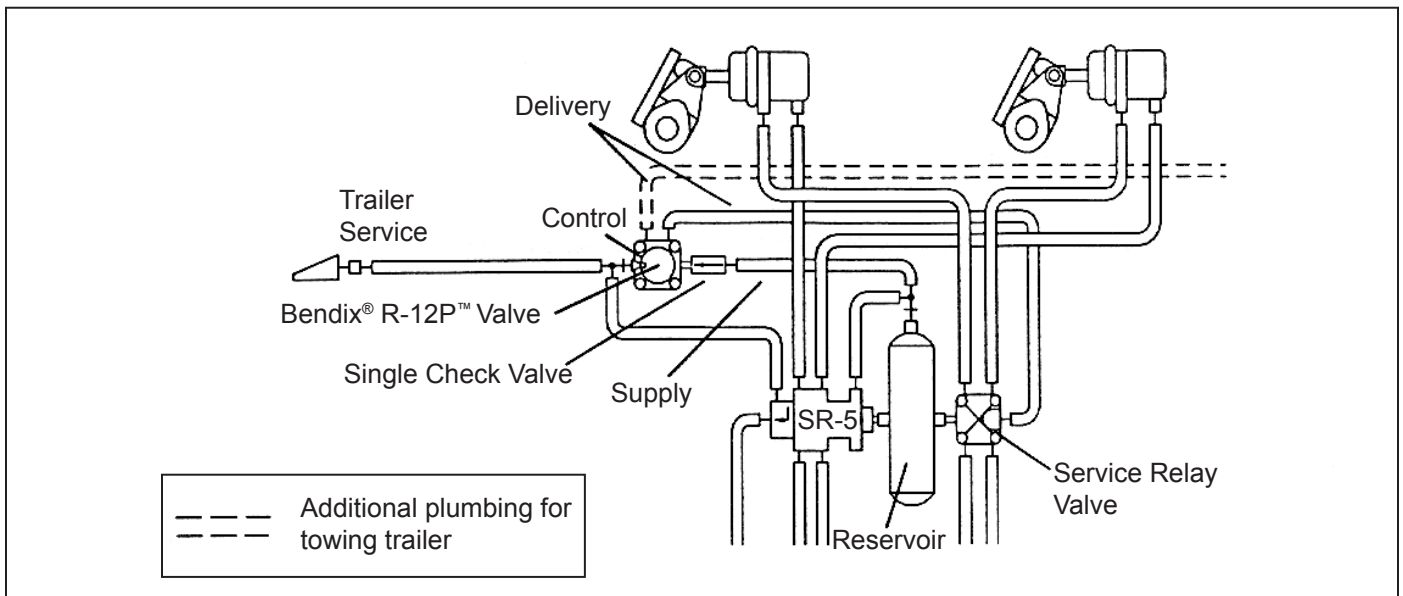

Figure 2 – Trailer System with Bendix® R-12P™ Pilot Relay Valve

REMOVAL

1. Identify and mark or label all air lines and their connections to the existing valve (Bendix® R-8P™ or R-12P™) and the single check valve, if present. Then disconnect the air lines.
2. Remove the valve from the vehicle.

INSTALLATION

1. Install the R-12P valve on the vehicle. Use the mounting bracket provided with the valve, or, if securing the valve to a reservoir, use a Schedule 80 (heavy wall) short couple pipe nipple.
2. Reconnect all air lines to the valve using the identification made during removal. NOTE: When replacing an R-8P valve, it may be necessary to use reducer fittings.
3. Perform OPERATIONAL AND LEAKAGE TESTS before placing the vehicle back into service.

OPERATIONAL AND LEAKAGE TESTS

1. Block the vehicle's wheels and fully charge the air system.
2. Inspect all air lines connected to the valve for signs of wear or physical damage. Repair/replace as necessary. Also, test air line fittings for excessive leakage and tighten or replace as necessary.

3. Apply and release the service brakes several times and check for prompt response of the brakes at all appropriate wheels.
4. With the air system fully charged, apply a soap solution to the R-12P exhaust port. Leakage of a 1" bubble in five seconds is permissible.
5. Make and hold a full brake application and again apply a soap solution to the R-12P exhaust. Leakage of a 1" bubble in three seconds is permissible.
6. With the brakes still applied, apply a soap solution around the valve where the cover meets the body. No leakage at this point is permitted.

If the valve does not function as described; or if leakage is excessive, repair the valve or replace it at any authorized Bendix® parts outlet.

NOTE: If a supply line single check valve is present, check it for leakage. Disconnect the inlet side of the single check valve and coat the open end with a soap solution. Make and hold a full brake application. Leakage of a 1" bubble in five seconds is permissible. If the valve's leakage is excessive, replace it with a 1/2" single check valve.

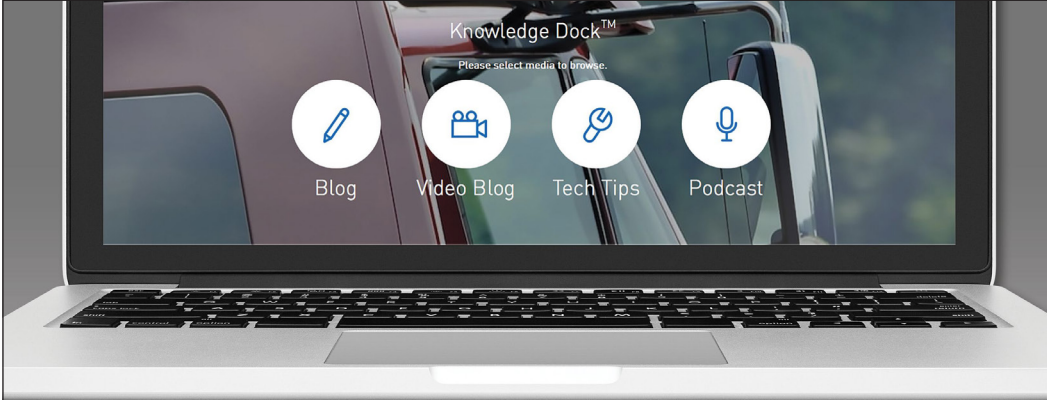

Trucking moves fast. Move faster.
Knowledge Dock™
• BLOGS • PODCASTS • VIDEOS • 24/7/365
[knowledge-dock.com]



Log-on and Learn from the Best
On-line training that's available when you are – 24/7/365.
Visit brake-school.com.