

Installation Instructions

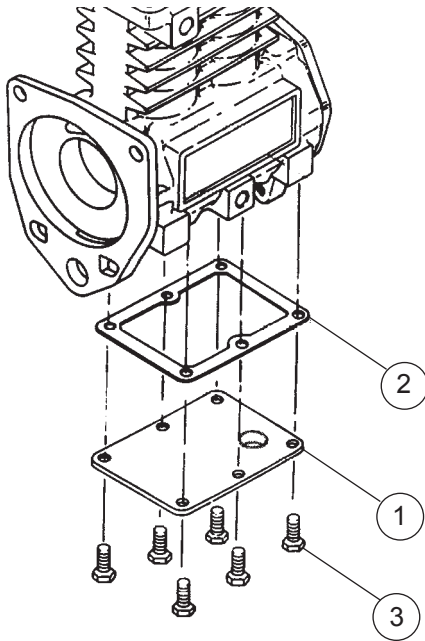

BENDIX® TU-FLO® 550 COMPRESSOR DRAIN COVER KIT



Bendix® Tu-Flo® 550 Compressor

Kit Contents		
Item No	Description	Qty.
1	Crankcase Cover	1
2	Crankcase Gasket	1
3	Mounting Bolt	6

Figure 1 – Installation Diagram



GENERAL SAFETY GUIDELINES

WARNING! PLEASE READ AND FOLLOW THESE INSTRUCTIONS

TO AVOID PERSONAL INJURY OR DEATH:

When working on or around a vehicle, the following guidelines should be observed **AT ALL TIMES**:

- ▲ Park the vehicle on a level surface, apply the parking brakes and always block the wheels. Always wear personal protection equipment.
- ▲ Stop the engine and remove the ignition key when working under or around the vehicle. When working in the engine compartment, the engine should be shut off and the ignition key should be removed. Where circumstances require that the engine be in operation, **EXTREME CAUTION** should be used to prevent personal injury resulting from contact with moving, rotating, leaking, heated or electrically-charged components.
- ▲ Do not attempt to install, remove, disassemble or assemble a component until you have read, and thoroughly understand, the recommended procedures. Use only the proper tools and observe all precautions pertaining to use of those tools.
- ▲ If the work is being performed on the vehicle's air brake system, or any auxiliary pressurized air systems, make certain to drain the air pressure from all reservoirs before beginning ANY work on the vehicle. If the vehicle is equipped with a Bendix® AD-IS® air dryer system, a Bendix® DRM™ dryer reservoir module, or a Bendix® AD-9si® air dryer, be sure to drain the purge reservoir.
- ▲ Following the vehicle manufacturer's recommended procedures, deactivate the electrical system in a manner that safely removes all electrical power from the vehicle.
- ▲ Never exceed manufacturer's recommended pressures.
- ▲ Never connect or disconnect a hose or line containing pressure; it may whip and/or cause hazardous airborne dust and dirt particles. Wear eye protection. Slowly open connections with care, and verify that no pressure is present. Never remove a component or plug unless you are certain all system pressure has been depleted.
- ▲ Use only genuine Bendix® brand replacement parts, components and kits. Replacement hardware, tubing, hose, fittings, wiring, etc. must be of equivalent size, type and strength as original equipment and be designed specifically for such applications and systems.
- ▲ Components with stripped threads or damaged parts should be replaced rather than repaired. Do not attempt repairs requiring machining or welding unless specifically stated and approved by the vehicle and component manufacturer.
- ▲ Prior to returning the vehicle to service, make certain all components and systems are restored to their proper operating condition.
- ▲ For vehicles with Automatic Traction Control (ATC), the ATC function must be disabled (ATC indicator lamp should be ON) prior to performing any vehicle maintenance where one or more wheels on a drive axle are lifted off the ground and moving.
- ▲ The power **MUST** be temporarily disconnected from the radar sensor whenever any tests **USING A DYNAMOMETER** are conducted on a vehicle equipped with a Bendix® Wingman® system.
- ▲ You should consult the vehicle manufacturer's operating and service manuals, and any related literature, in conjunction with the Guidelines above.

DISASSEMBLY

1. Drain the air system.
2. Drain the engine oil (as necessary), remove and discard the existing crankcase cover (1). Retain the mounting hardware.

INSTALLATION

1. Clean the crankcase flange, removing all previous gasket material etc., taking care not to damage or gouge the surface.
2. Align the gasket (2), crankcase cover (1), and mounting bolts (3). Install all bolts hand tight before tightening in a cross-pattern to 200 in-lbs.
3. Install a pipe fitting into the baseplate fitting. Plumb the oil return from the fitting to the engine oil sump as required by the particular vehicle configuration.
4. Restore the oil supply to the compressor and start the engine. Visually inspect the crankcase gasket (2) and oil return lines for leaks and repair as needed before returning the vehicle to service.

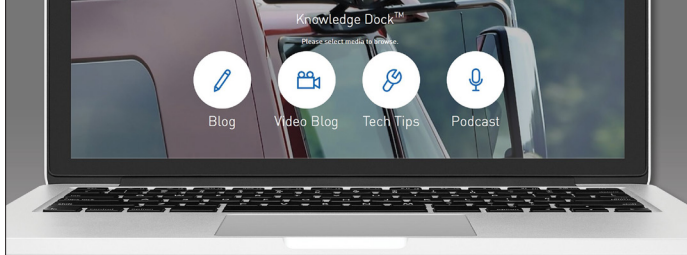

Trucking moves fast. Move faster.

Knowledge Dock™

• BLOGS • PODCASTS • VIDEOS • 24/7/365

[knowledge-dock.com]



Log-on and Learn from the Best

On-line training that's available when you are – 24/7/365.

Visit www.brake-school.com.