



Instructions for the Vertical and Lateral Alignment of Bendix Radar Sensors

This is an extract from the Bendix Service Data Sheet SD-13-4962 Bendix® Wingman® Advanced™. To download the full document, visit the document library on www.bendix.com, or order copies from the literature center on the web site.

Be sure to follow the General Safety Guidelines on the final page of this document.

6.0 BENDIX® WINGMAN® ADVANCED™ RADAR SENSOR MOUNTING AND INSTALLATION SECTION

Note: This section only covers Bendix-supplied mounting arrangements. (See Figure 23 for Bendix-supplied mounting arrangement. At time of printing, Bendix-supported mounting arrangements are used on Mack® and Volvo® trucks). For other mounting arrangements consult the OEM.

6.01 VEHICLE APPLICATIONS

The radar sensor can be mounted and installed only on vehicles that have Wingman Advanced already installed. At this time Wingman Advanced can not be retrofitted onto vehicles, even if that vehicle is equipped with the Bendix® ESP® stability system.

6.02 RADAR SENSOR MOUNTING

When mounting a radar sensor, the wire harness connector should always point down. The radar sensor assembly is mounted to the front of the vehicle using an adjustable

bracket. This adjustable bracket allows for the radar sensor to be properly aimed laterally and vertically to maximize Wingman Advanced system performance.

The assembly should always be mounted in the original OEM location. If this location is not in the center of the vehicle, the mounting offset will need to be programmed through Bendix® ACom® Diagnostics software; see Section 6.09: Check Lateral Alignment.

For proper operation of your Wingman Advanced system, adhere to the following guidelines:

- The radar sensor assembly should be rigidly installed on the vehicle following all OEM recommended torque specifications.
- The radar sensor assembly should be installed in the original OEM designated location.
- The radar sensor cover should always be installed. This helps protect components such as the connector and wiring harness from road debris.
- The radar sensor assembly must be oriented so that the electrical connector points down. **Mounting the radar upside down will impair performance significantly.**
- The radar's field of view must NOT have interference from any other vehicle components such as bumpers, cow-catcher bumpers, engine blankets, seasonal decorations, or any other commonly mounted front-of-vehicle components.

NOTE: If original OEM installation was behind a translucent panel, this panel must be reinstalled. Check the panel for damage or scratches that may impact the performance of Advanced. Replace the panel, if necessary, with an original OEM supplied panel. **Do not paint over the panel.**

6.03 REPLACEMENT PARTS

Replacement parts exist for all components shown in Figure 23. Parts are available from any Bendix authorized parts supplier.

<p>Typical Radar Sensor Assembly</p>	<p>Typical Advanced Assembly with Adapter Plate</p>	<p>Advanced Cover</p>
<ul style="list-style-type: none"> • Advanced Radar sensor (or Advanced Radar Sensor) • Adjustable Bracket • Cover Fasteners – Plastic Tree Style 	<ul style="list-style-type: none"> • Radar • Adjustable Bracket • Adapter Plate • Cover Fasteners – Plastic Tree Style 	<ul style="list-style-type: none"> • Cover Fasteners – Plastic Tree Style (Note: cover may vary depending on OEM installation)

FIGURE 23 - TYPICAL ADVANCED ASSEMBLIES AND COVER WITH SERVICE REPLACEMENT PARTS

6.04 RADAR SENSOR ALIGNMENT

Accurate vertical and lateral alignment of the radar sensor is critical for proper operation of Bendix® Wingman® Advanced™. Improper alignment will cause false warnings, missed warnings and a diagnostic trouble code in the system.

The radar sensor is mounted to the front of the vehicle using an adjustable bracket. Use the following procedures to align the radar sensor in its adjustable bracket:

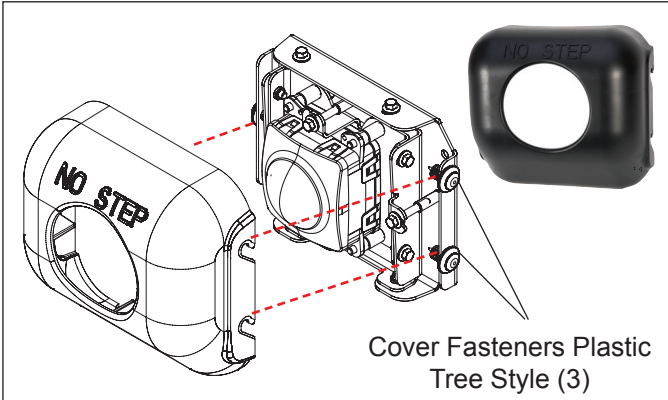

FIGURE 24 - COVER AND PLACEMENT OVER RADAR SENSOR ASSEMBLY

6.05 COVER REMOVAL

To remove the cover, use a slight force to pull the cover up and away from the bracket. The three cover fasteners do not need to be removed. See Figures 24 and 25.



FIGURE 25 - COVER REMOVAL

6.06 BENDIX® ALIGNMENT TOOLS

The Bendix® Alignment Tools (Bendix part nos: K065284, K041451, or K041227) - available from Bendix parts outlets - are used to align the radar sensor both vertically and laterally. They fasten magnetically to the radar sensor assembly for easy placement and removal. See Figures 26-28.

6.07 CHECK THE RADAR SENSOR VERTICAL ALIGNMENT

See Section 6.06 for the Bendix® Alignment Tools available. Additionally, Bendix strongly recommends that a digital inclinometer should be when checking the vertical alignment of the radar sensor.

6.07.1 Remove the cover as shown in Section 6.05: Cover Removal.

6.07.2 If the vehicle has an air suspension system, charge the system and set it to “level” prior to carrying out a radar sensor check or alignment procedure. If the system is not charged, the vertical alignment will be off and the Wingman Advanced system will not perform correctly.

6.07.3 For an accurate check (and adjustment, if necessary) of the vertical alignment, the vehicle needs to be parked on a flat, level surface.

NOTE: If the service technician is unable to park the vehicle on a level floor, a digital inclinometer must be used to align the sensor vertically.

6.07.4. Position the alignment tool over the sensor so that it straddles the sensor. Attach the alignment tool to the bracket/sensor assembly using its magnet attachments. Use the Lateral Alignment level to make sure that the alignment tool is approximately horizontal width-wise. See Figures 27 and 28.

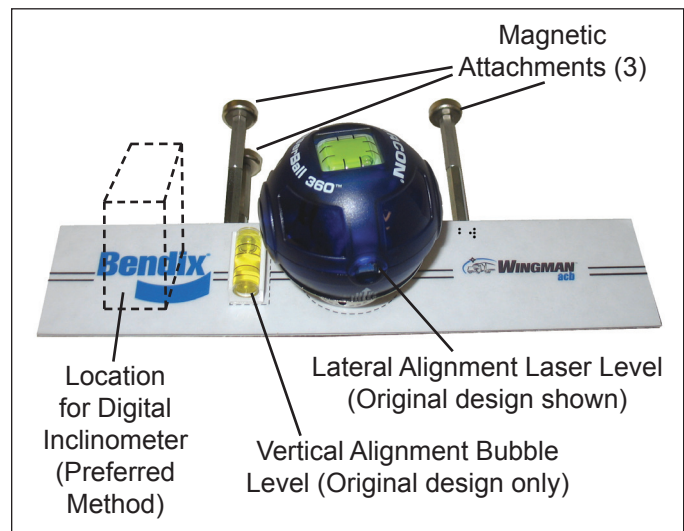

FIGURE 26 - BENDIX® ALIGNMENT TOOL (K041451 OR K041227)

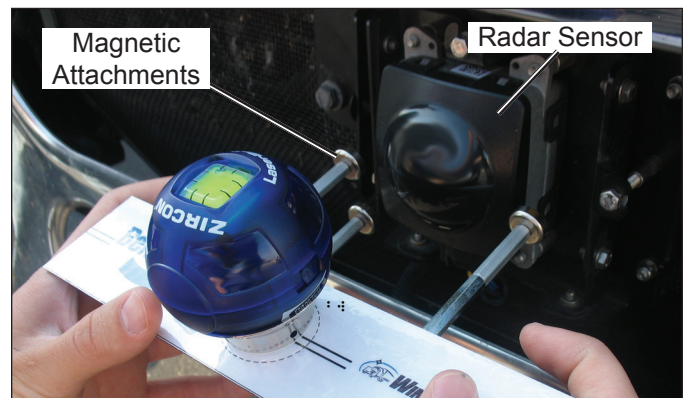

FIGURE 27 - ATTACHING THE ALIGNMENT TOOL (SHOWS TOOL K041451 OR K041227)

6.07.5 Check the vertical Alignment.

Using the standard tool K065284. With the air suspension charged and set to “level”, calibrate (“zero”) the inclinometer on a horizontal section of the frame rail.

Follow the manufacturer's instructions (typically digital inclinometers have a "SET" button for this purpose).

Check the alignment with the alignment tool in position so that it straddles the radar sensor. **Verify that the radar is aligned downward**, towards the road surface in front of the vehicle, **by -1.3° ($\pm 0.8^\circ$)**, when measured by an inclinometer set to zero on the vehicle's frame. If the sensor is not aligned correctly, follow the instructions in section 6.08.

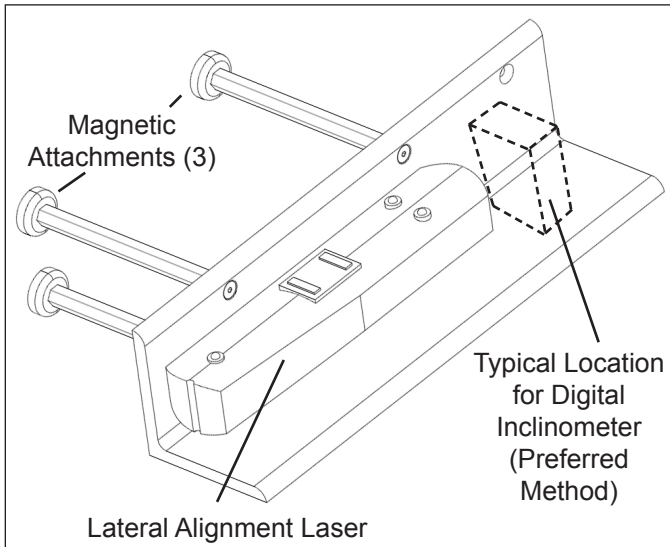

FIGURE 28 - VERTICAL ALIGNMENT TOOL (K065284)

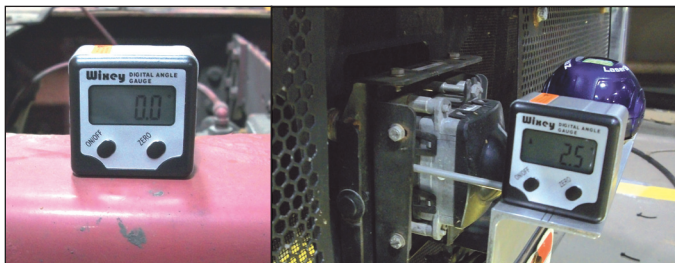

FIGURE 29 - INCLINOMETER

6.07.6 If you have the original design of alignment tool K041451 or K041227 (See Figure 26):

Where a digital inclinometer is available — or if a flat, level location is not available (in which case a digital inclinometer **must** be used) — do not use the bubble level.

Verify that the radar is aligned downward, towards the road surface in front of the vehicle, **by -1.3° ($\pm 0.8^\circ$)**, when measured by an inclinometer set to zero on the vehicle's frame.

Where the bubble-level may be used, verify that the bubble just touches the line nearest the vehicle. This shows that an incline of approximately one half of a degree downward has been set. See Figure 31.



FIGURE 30 - VERTICAL ALIGNMENT BUBBLE LEVEL

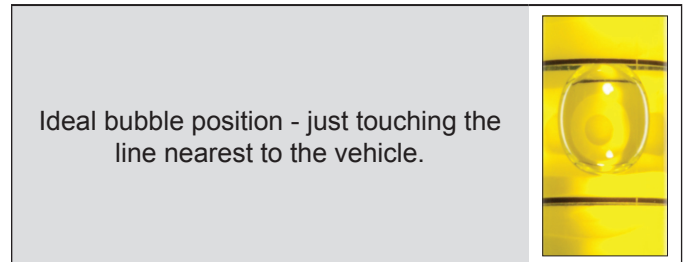

FIGURE 31 - USING THE BUBBLE POSITION TO CHECK THE VERTICAL ALIGNMENT (VEHICLE ON LEVEL GROUND)

If the sensor is not aligned correctly, follow the instructions in section 6.08

6.08 RADAR SENSOR VERTICAL ALIGNMENT ADJUSTMENT PROCEDURE

NOTE: Complete these steps only if a vertical adjustment is necessary.

Tools needed:

7 mm box wrench and Bendix® alignment tool.

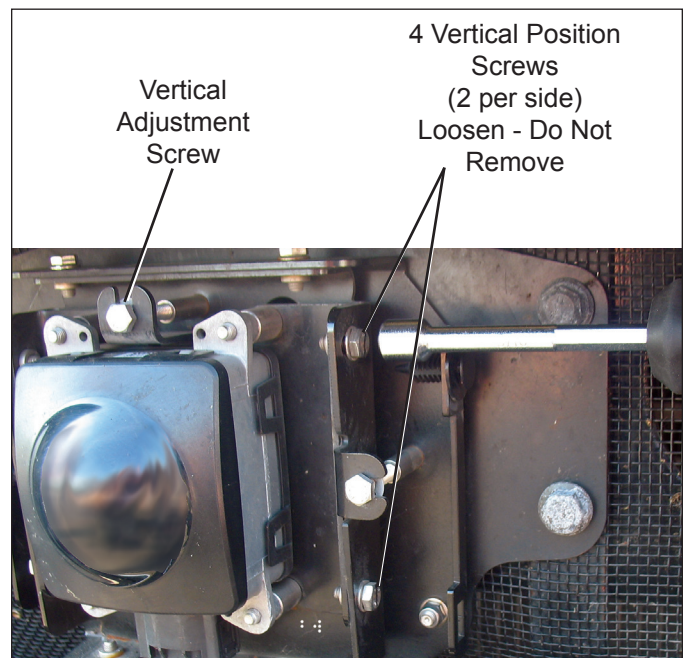

FIGURE 32 - VERTICAL ADJUSTMENT (NOTE THIS IMAGE DOES NOT SHOW THE ALIGNMENT TOOL INSTALLED)

1. Be sure the vehicle is prepared as shown in Sections 6.07.1-3.
2. With the Bendix alignment tool still in place, loosen the four vertical position screws. DO NOT remove these screws. See Figure 31. During the adjustment, turn the vertical alignment screw clockwise or counterclockwise depending on the vertical direction (up or down) needed. Clockwise aligns the radar sensor up and counterclockwise moves the radar sensor down.
3. **Where the original tool is being used: (kits K041451 or K041227)**
In cases where a digital inclinometer is not being used, the adjustment should be made until the bubble is just touching the line closest to the vehicle (See Figure 31.)
4. **Where a digital inclinometer is being used:**
Adjust the vertical adjustment screw until the digital inclinometer shows that **the radar is aligned downward**, towards the road surface in front of the vehicle, **by -1.3° ($\pm 0.8^\circ$)**, when measured by an inclinometer set to zero on the vehicle's frame. (See Figure 29.)
5. Re-tighten the four vertical position screws to hold desired alignment in place.
6. Re-check the vertical alignment after tightening the four vertical position screws.

Note: The alignment process shown here is for Bendix alignment brackets. For other brackets, similar alignment steps will be needed; consult the vehicle manual for full instructions.

6.09 CHECK THE RADAR SENSOR LATERAL ALIGNMENT

See Section 6.06 for available Bendix® Alignment Tools.

Tools needed: 7 mm box wrench, Bendix® alignment tool and a tape measure.

1. Park the vehicle on a flat, level surface. The vertical alignment must be checked and adjusted, if needed, before the lateral adjustment can be made.
2. Remove the cover as shown previously in Section 6.05: *Cover Removal*.
3. Position the alignment tool over the radar sensor so that it straddles the radar sensor. Attach the alignment tool to the bracket / radar sensor assembly with its magnet attachments. See Figures 33 and 34.
4. Activate the lateral alignment laser light “on” switch.
For kits K041451 or K041227, position and place it in its cradle, making sure it is sitting level, and align the laser beam between the reference lines on the Bendix alignment tool left or right. See Figure 32.

For kit K065284, place the tool into position for the first measurement. (The tool will be reversed when the second measurement is made.)

5. Using a ruler or tape measure, measure the distance from a symmetrical vehicle point (such as the tow hooks) to the laser light line. Record this measurement. See Figure 35.

NOTE: The technician must be extremely careful during the laser positioning process to double-check the values measured on each side of the truck. Be sure to check back and forth for each side of the radar sensor several times to ensure accuracy.

6. Repeat the same process for the opposite side and measure the reference distance to the laser line. For tool K042452, the blue laser level is rotated 180 degrees, and for tool K065284, the whole tool is reversed so that the laser light points to the other side of the vehicle.
7. Compare the left and right distance measurements. A properly aligned radar sensor will have the same measurement from side to side. If these two dimensions are within 1/8" (3 mm), no alignment is necessary. If not, follow the instructions in Section 6.10: *Lateral Adjustment Procedure*.

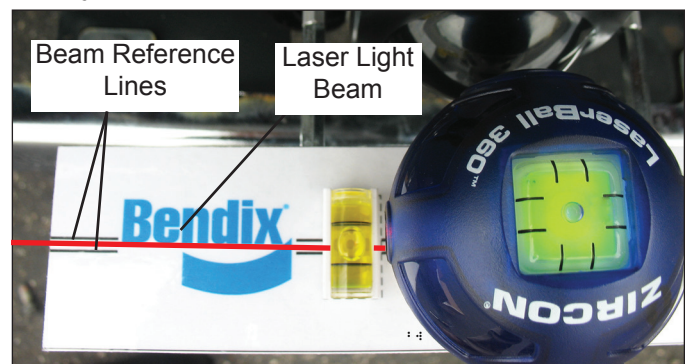

FIGURE 33 - POSITIONING THE LASER LEVEL (KITS K041451 OR K041227)

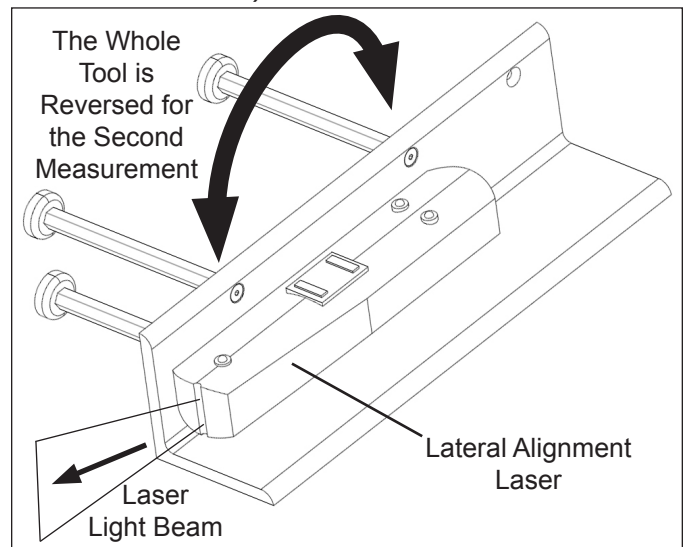

FIGURE 34 - USING THE LATERAL ALIGNMENT LEVEL (KIT K065284)

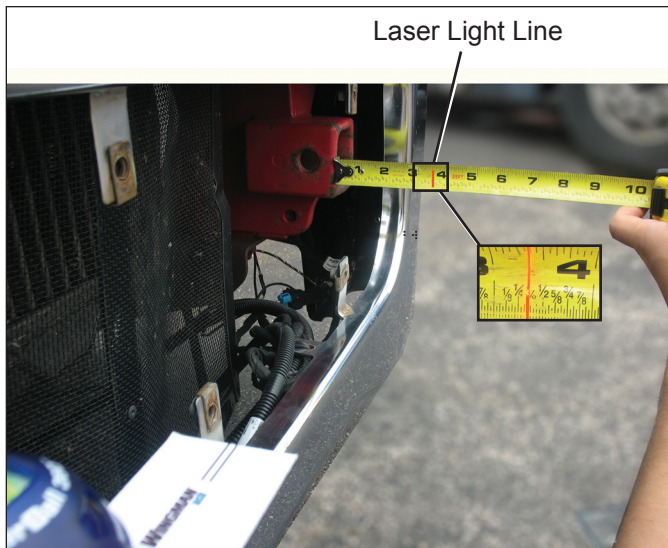

FIGURE 35 - LATERAL ALIGNMENT VERIFICATION

NOTE: The lateral alignment also can be checked with Bendix ACom® Diagnostics (version 6.3 or higher). A value between -0.8° and 0.8° is acceptable and the system should operate normally. A value between -0.8° to -1.3° OR 0.8° to 1.3° means the radar sensor is misaligned and system performance will be degraded. The service technician should align the radar sensor using the procedures noted in this section.

If the value is less than ($<$) -1.3° , or greater than ($>$) 1.3° , the system will typically issue a Diagnostic Trouble Code. The service technician should align the radar sensor laterally. A positive value means the radar sensor should be aligned toward the driver side. A negative value means the radar sensor should be aligned towards the passenger side. The vehicle must be driven at least 20 miles between adjustments. See “Alignment Value” in Figure 17.

6.10 LATERAL ADJUSTMENT PROCEDURE

NOTE: Complete these steps only if a vertical adjustment is necessary.

1. Loosen the four lateral position screws. DO NOT fully remove them. See Figure 36.

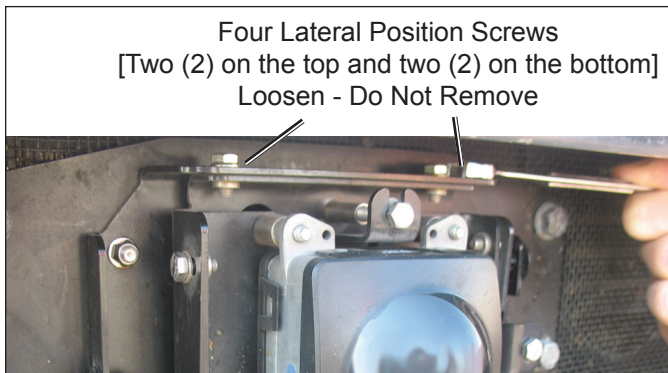

FIGURE 36 - LATERAL POSITION SCREWS

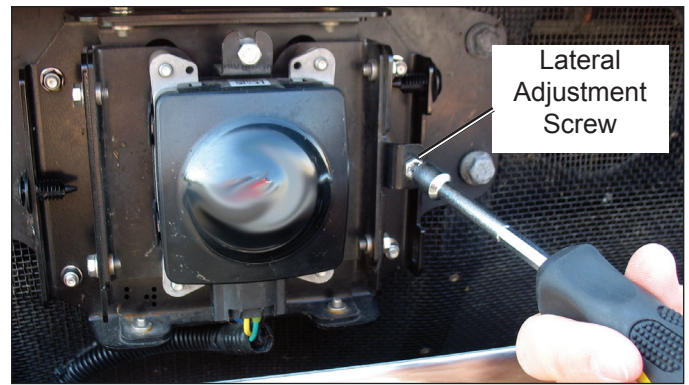

FIGURE 37 - LATERAL ADJUSTMENT

2. See Figure 37. Adjust the lateral adjustment screw until the desired alignment is reached. DO NOT remove the screws. Use steps 4 through 7 in Section 6.09: Check Lateral Alignment section to measure.
3. Retighten the four lateral position screws to hold the desired alignment in place.
4. Recheck the lateral alignment as described above.
5. After the lateral alignment procedure is complete, if there is an active misalignment DTC (codes 55, 56, or 57), reset the alignment value using the procedure in Section 6.11.

6.11 RESET LATERAL ALIGNMENT VALUE IN BENDIX® ACOM® DIAGNOSTICS

If a “radar alignment” diagnostic trouble code (DTC) was logged, after repairs, the vehicle will need to be connected to a PC with ACom Diagnostics software to reset the “Alignment Value” to zero.

1. In ACom Diagnostics select Wingman Advanced on the starter screen, and then select “Start with ECU.”
2. Select “Config” on the Wingman Advanced Status window.
3. Select “Modify” on the Configuration Status window.
4. Select “Reset Alignment Value” in the Change Configuration box.
5. Select “Write” button in the dialogue box.
6. Clear the Bendix® Wingman® Advanced™ system trouble code using the procedure in Section 4.4: Clearing Diagnostic Trouble Codes (DTCs). Also, see Appendix D.
7. Close the ACom Diagnostics program and any open windows.
8. Cycle the vehicle ignition.

6.12 REINSTALL THE PLASTIC COVER

With a slight force, push the cover onto the bracket so that the plastic fasteners line up with the slots on the plastic cover. Ensure the cover is secure over the radar sensor assembly before driving the vehicle.

7.0 GENERAL SAFETY GUIDELINES

 WARNING! PLEASE READ AND FOLLOW THESE INSTRUCTIONS TO AVOID PERSONAL INJURY OR DEATH:

When working on or around a vehicle, the following general precautions should be observed at all times.

1. Park the vehicle on a level surface, apply the parking brakes, and always block the wheels. Always wear safety glasses.
2. Stop the engine and remove ignition key when working under or around the vehicle. When working in the engine compartment, the engine should be shut off and the ignition key should be removed. Where circumstances require that the engine be in operation, EXTREME CAUTION should be used to prevent personal injury resulting from contact with moving, rotating, leaking, heated or electrically charged components.
3. Do not attempt to install, remove, disassemble or assemble a component until you have read and thoroughly understand the recommended procedures. Use only the proper tools and observe all precautions pertaining to use of those tools.
4. If the work is being performed on the vehicle's air brake system, or any auxiliary pressurized air systems, make certain to drain the air pressure from all reservoirs before beginning ANY work on the vehicle. If the vehicle is equipped with a Bendix® AD-IS® air dryer system or a dryer reservoir module, be sure to drain the purge reservoir.
5. Following the vehicle manufacturer's recommended procedures, deactivate the electrical system in a manner that safely removes all electrical power from the vehicle.
6. Never exceed manufacturer's recommended pressures.
7. Never connect or disconnect a hose or line containing pressure; it may whip. Never remove a component or plug unless you are certain all system pressure has been depleted.
8. Use only genuine Bendix® brand replacement parts, components and kits. Replacement hardware, tubing, hose, fittings, etc. must be of equivalent size, type and strength as original equipment and be designed specifically for such applications and systems.
9. Components with stripped threads or damaged parts should be replaced rather than repaired. Do not attempt repairs requiring machining or welding unless specifically stated and approved by the vehicle and component manufacturer.
10. Prior to returning the vehicle to service, make certain all components and systems are restored to their proper operating condition.
11. For vehicles with Automatic Traction Control (ATC), the ATC function must be disabled (ATC indicator lamp should be ON) prior to performing any vehicle maintenance where one or more wheels on a drive axle are lifted off the ground and moving.