

Tolerances/Toleranzen/Tolérances/tolleranze					
Nominal dimensions in mm					
Cotes nominales en mm					
Dimensioni nominali in mm					
<6	>6	>10	>10	>120	>315
±1	±1.5	±2	±2.5	±3	±3

- General presentation, exact orientation of the components, see below.  
 - Allgemeine Darstellung, fuer genaue Teileorientierung; siehe Ansicht unten.  
 - Présentation générale, orientation exacte des pièces, voir vue en bas.  
 - Presentazione generale. Per l'orientazione corretta dei pezzi, vedere il disegno sotto.

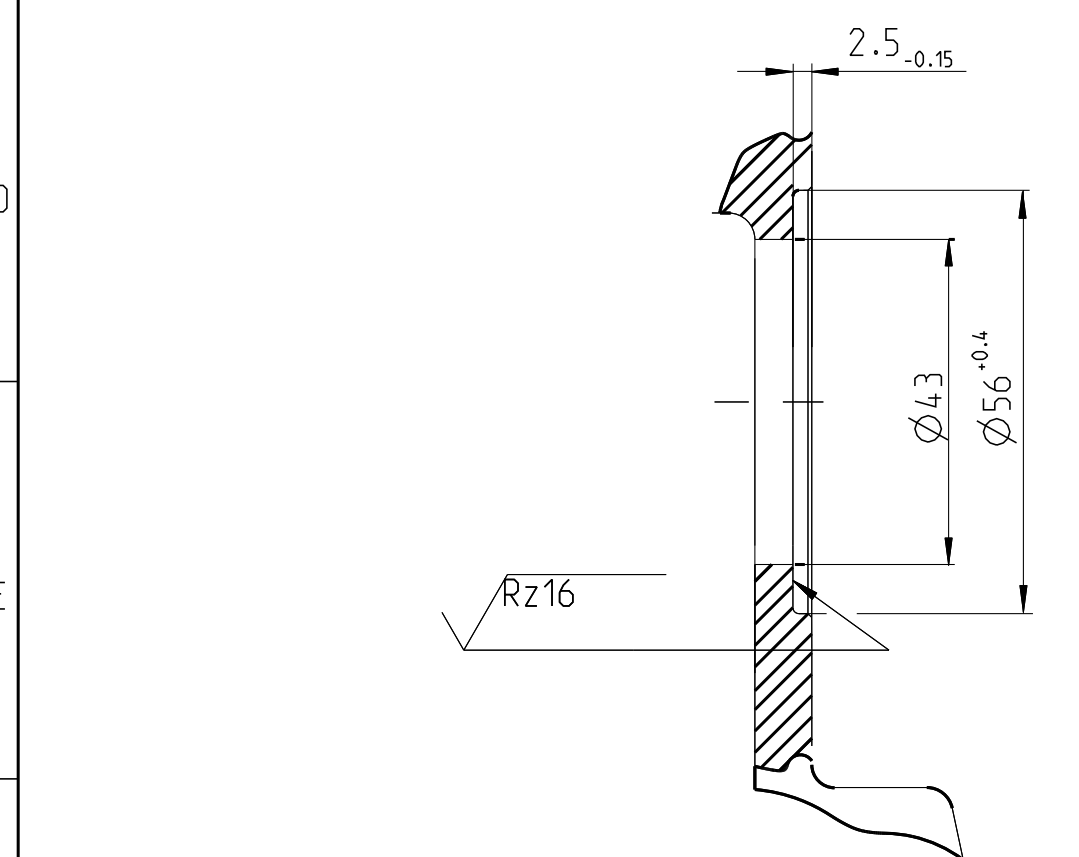
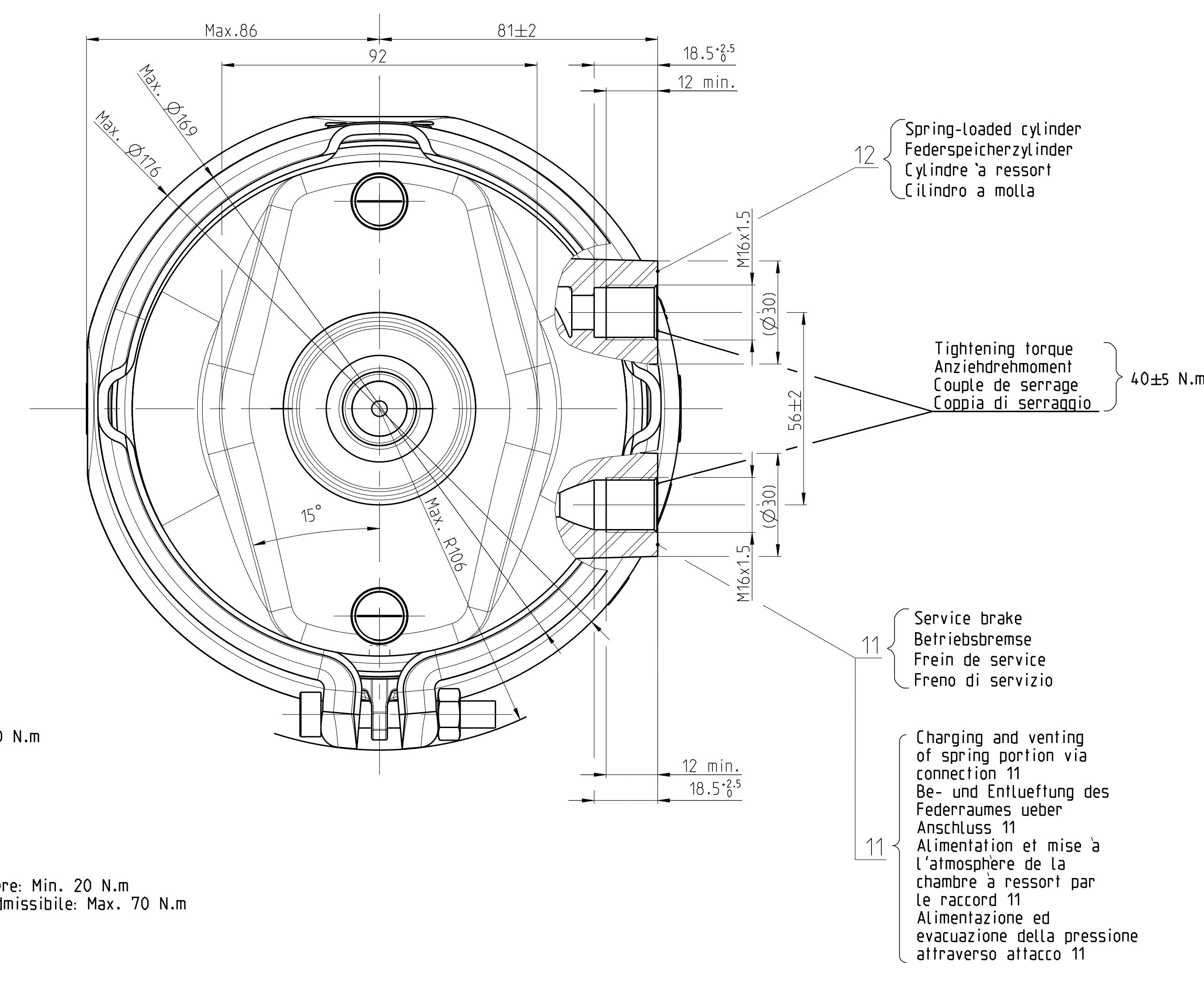
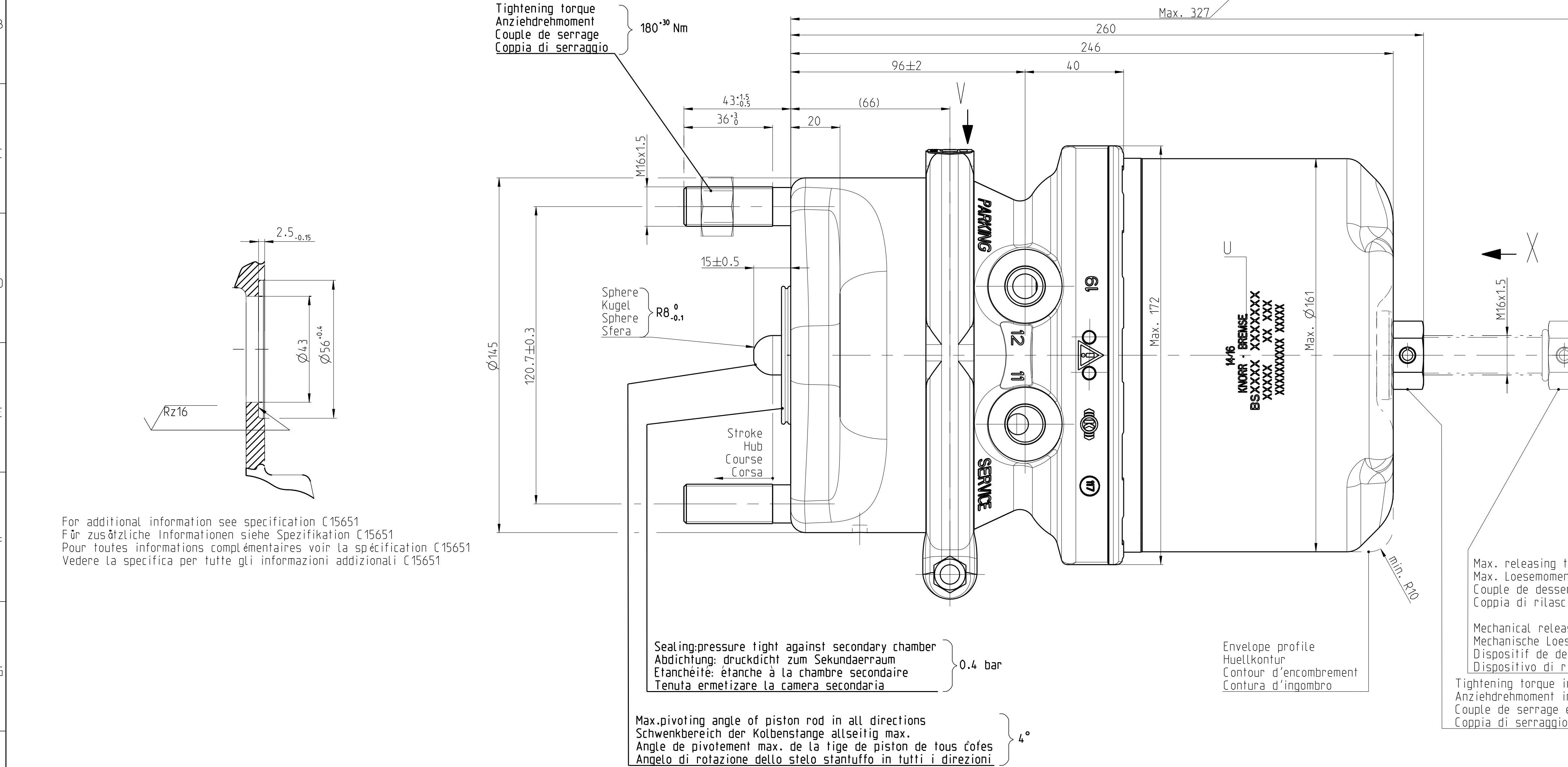

For additional information see specification C15651  
 Für zusätzliche Informationen siehe Spezifikation C15651  
 Pour toutes informations complémentaires voir la spécification C15651  
 Vedere la specifica per tutte gli informazioni addizionali C15651

Back-up solution  
 Backup Markierung  
 Mode dégradé  
 Soluzione di Back-up

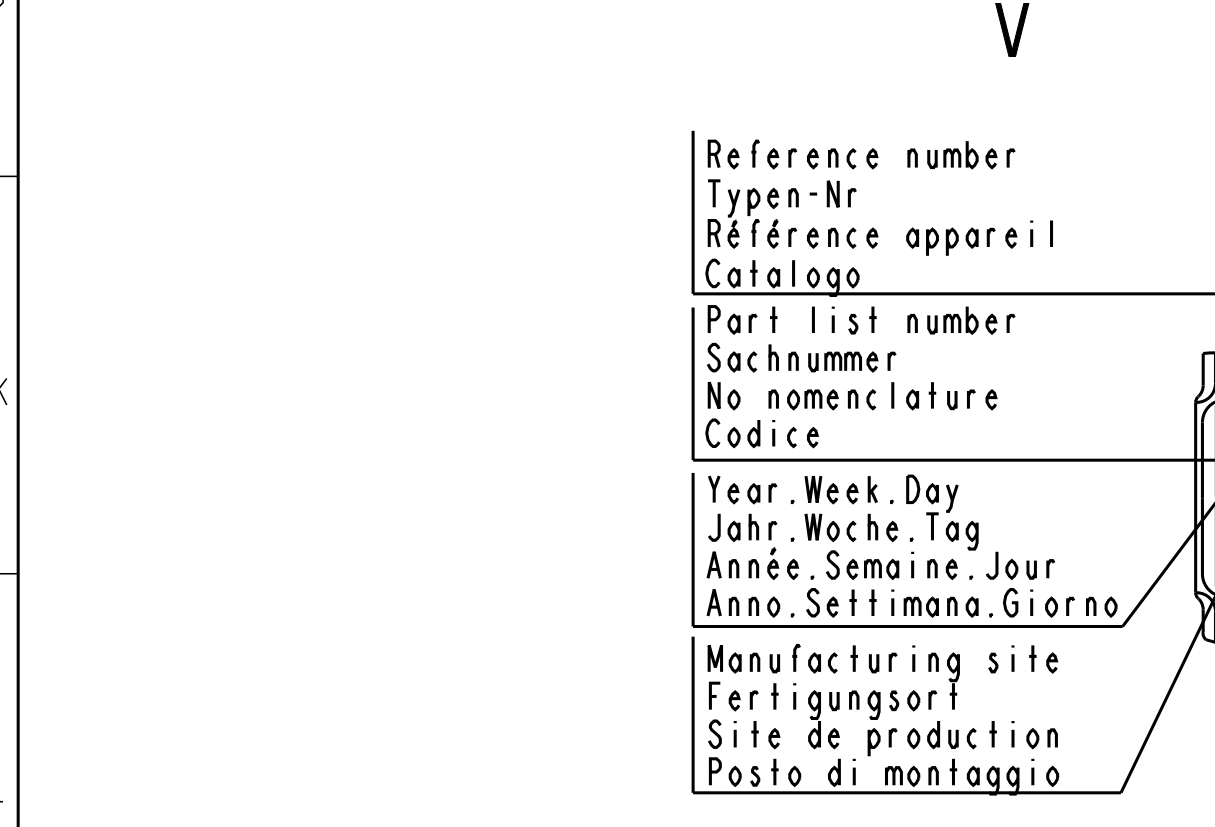

Operational uses specifications:  
 Max. operating pressure: 11 bar (10.5 bar)  
 Max. Betriebsdruck: 11 bar (10.5 bar)  
 Pression de service max.: 11 bar (10.5 bar)  
 Pressione d'esercizio max.: 11 bar (10.5 bar)

Required release pressure at stroke 5mm:  
 Erforderlicher Losedruck bei Hub 5mm: 5.2 ± 0.3 bar  
 Pression de desserrage nécessaire à une course de 5mm: 5.2 ± 0.3 bar  
 Pressione di rilascio necessaria per corsa di 5mm: 5.2 ± 0.3 bar

Diagram of service brake (Type 14)  
 Diagramm der Betriebsbremse  
 Diagramme du cylindre à ressort  
 Diagramma del freno di servizio

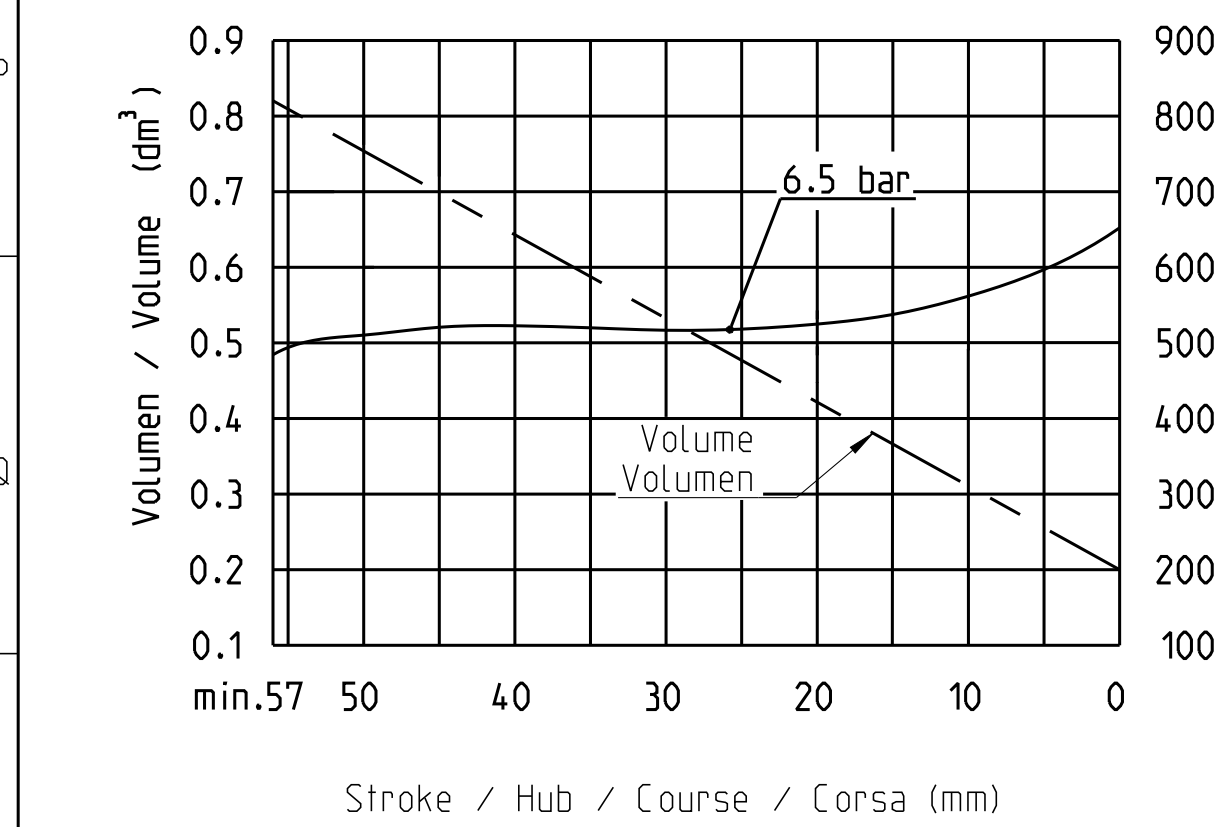

Force at piston rod  
 Kraft an der Kolbenstange  
 Effort à la tige de piston  
 Forza esercitata sul puntale

Critical uses specifications without part failure:  
 Max. pressure: 11 bar (13 bar)  
 Hoehstdruck: 11 bar (13 bar)  
 Pression max.: 11 bar (13 bar)  
 Pressione massima: 11 bar (13 bar)

Permissible leakage:  
 Zulaessige Undichtheit: 11 v<sub>n</sub> = 30 cm<sup>3</sup>/min (10.5 bar) S/C  
 Fuite admissible: stabilised/stabilisiert  
 Fuga d'aria ammissibile: stabilise/Stabilizzato

Permissible leakage:  
 Zulaessige Undichtheit: 12 v<sub>n</sub> = 30 cm<sup>3</sup>/min (8.5 bar) C/C  
 Fuite admissible: stabilised/stabilisiert  
 Fuga d'aria ammissibile: stabilise/Stabilizzato

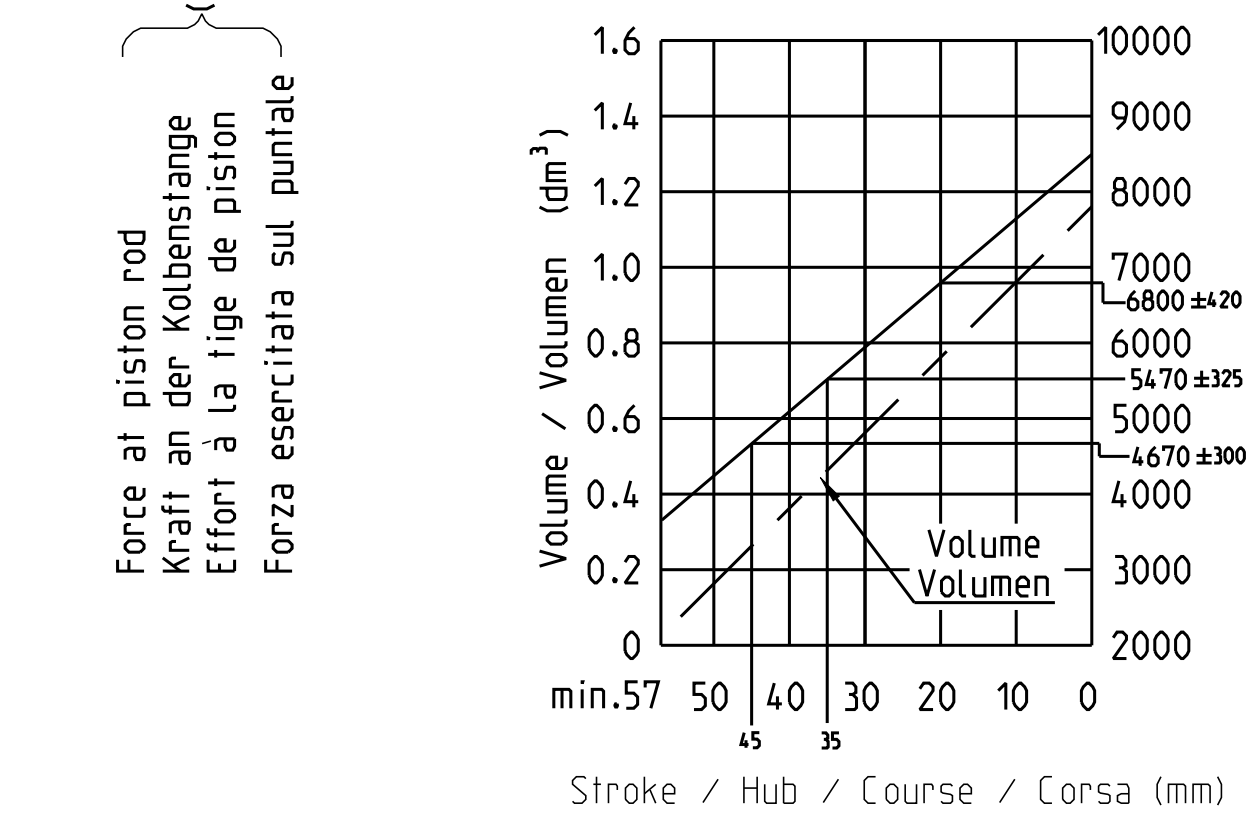

Force at piston rod  
 Kraft an der Kolbenstange  
 Effort à la tige de piston  
 Forza esercitata sul puntale

General specifications:  
 Medium: Air  
 Medium: Luft  
 Fluide: Air  
 Fluido: Aria

Designation of connection threads corresponding to DIN-ISO 6786  
 Anschlussbezeichnungen nach DIN-ISO 6786  
 Designations des raccords selon DIN-ISO 6786  
 Designazioni degli attacchi secondo DIN-ISO 6786

Minimum pressure: 11 bar (2 bar)  
 Minimum Druck: 11 bar (2 bar)  
 Pression minimale: 11 bar (2 bar)  
 Pressione minima: 11 bar (2 bar)

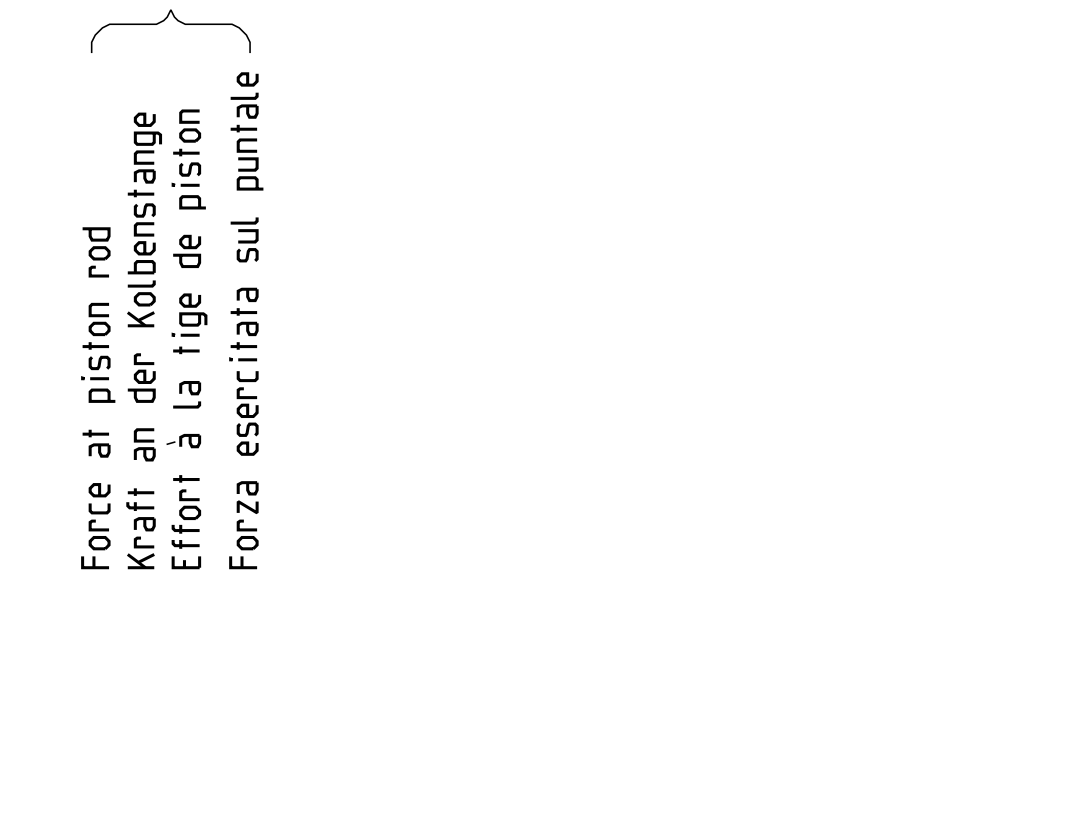

Minimum pressure  
 Minimum Druck  
 Pression minimale  
 Pressione minima

Temperature range:  
 Therm. Anwendungsbereich: -40°C bis +110°C / 1 hour  
 Plage de température: -40°C à +110°C (for example painting)  
 Campo termico di applicazione: -40°C a +110°C (per esempio pittura)

Designation of connection threads corresponding to DIN-ISO 1219  
 Anschlussbezeichnungen nach DIN-ISO 1219  
 Designations des raccords selon DIN-ISO 1219  
 Designazioni degli attacchi secondo DIN-ISO 1219

Pressure rising min.: 11 bar (3 bar/v)  
 Druckgradient min.: 11 bar (3 bar/v)  
 Montée en pression min.: 11 bar (3 bar/v)  
 Aumento della pressione min.: 11 bar (3 bar/v)

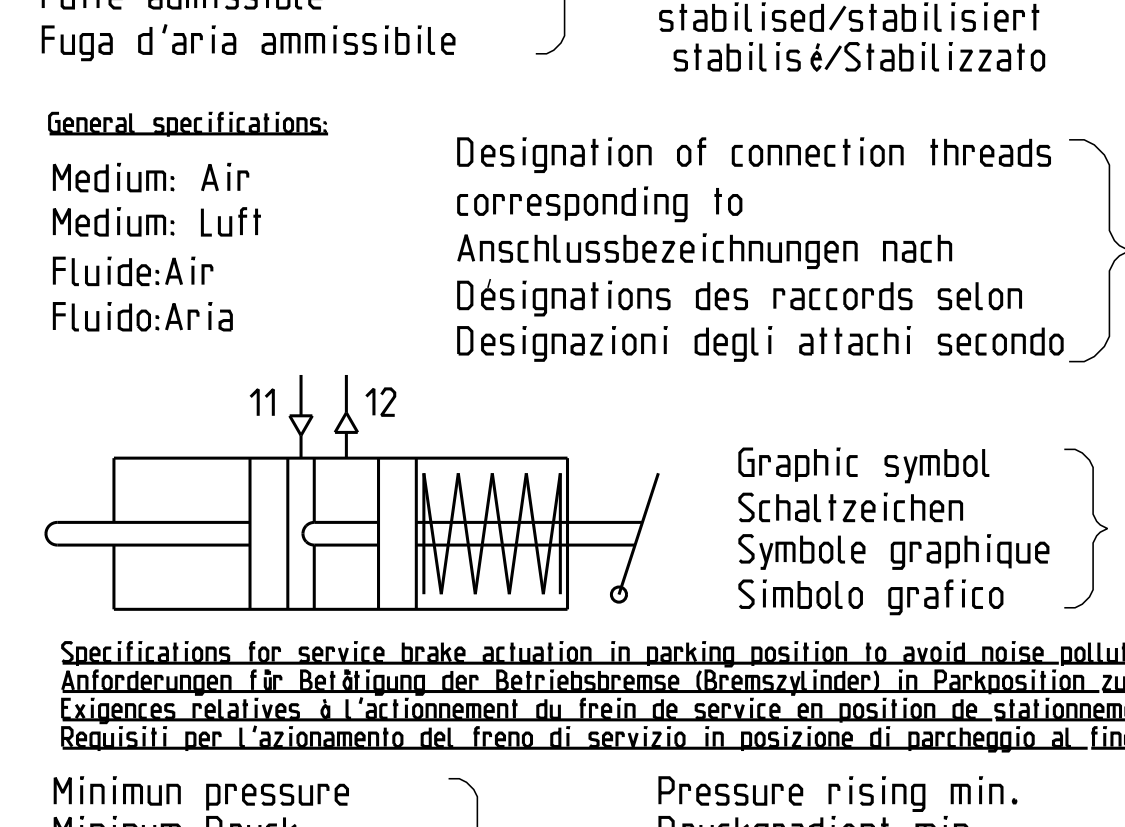

Breather hole opened  
 Atmungsböhrung geöffnet  
 Trou de respiration ouvert  
 Foro di respirazione aperto

Specifications for service brake actuation in parking position to avoid noise pollution:  
 Anforderungen für Betätigung der Betriebsbremse (Bremszylinder) in Parkposition zur Vermeidung von Geräuschen:  
 Exigences relatives à l'actionnement du frein de service en position de stationnement afin d'éviter toute nuisance sonore:  
 Requisiti per l'azionamento del freno di servizio in posizione di parcheggio al fine di evitare l'inquinamento acustico.

Minimum pressure: 11 bar (2 bar)  
 Minimum Druck: 11 bar (2 bar)  
 Pression minimale: 11 bar (2 bar)  
 Pressione minima: 11 bar (2 bar)

Pressure rising min.: 11 bar (3 bar/v)  
 Druckgradient min.: 11 bar (3 bar/v)  
 Montée en pression min.: 11 bar (3 bar/v)  
 Aumento della pressione min.: 11 bar (3 bar/v)

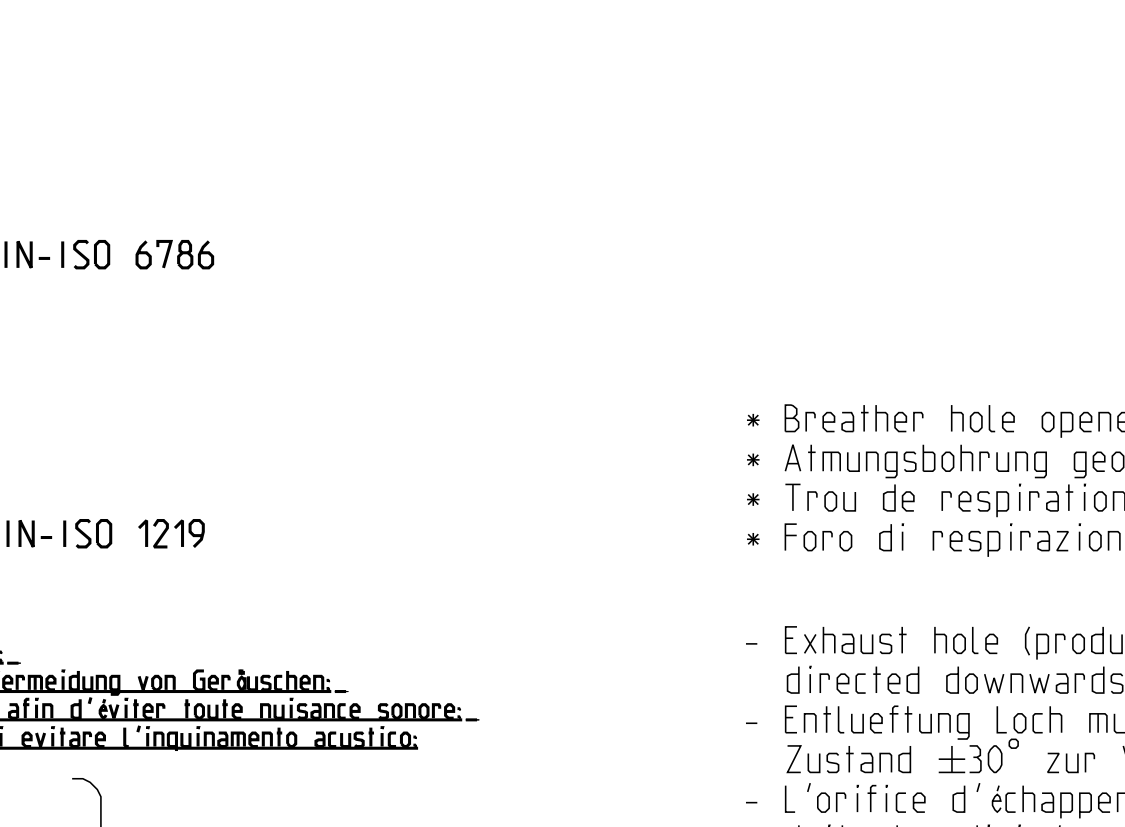

Breather hole opened  
 Atmungsböhrung geöffnet  
 Trou de respiration ouvert  
 Foro di respirazione aperto



At choice, with or without form  
 Wahlweise, mit oder ohne Form  
 Au choix, avec ou sans forme  
 Secondo scelta, con o senza forma

The position of the nose relative to the circumference is unspecified  
 Position des Vorsprungs am Umfang beliebig  
 Position du bossage indifférente par rapport à la circonférence  
 Qualunque posizione del naso possibile sulla circonferenza

Operational uses specifications:  
 Max. operating pressure: 11 bar (10.5 bar)  
 Max. Betriebsdruck: 11 bar (10.5 bar)  
 Pression de service max.: 11 bar (10.5 bar)  
 Pressione d'esercizio max.: 11 bar (10.5 bar)

Required release pressure at stroke 5mm:  
 Erforderlicher Losedruck bei Hub 5mm: 5.2 ± 0.3 bar  
 Pression de desserrage nécessaire à une course de 5mm: 5.2 ± 0.3 bar  
 Pressione di rilascio necessaria per corsa di 5mm: 5.2 ± 0.3 bar

Diagram of service brake (Type 14)  
 Diagramm der Betriebsbremse  
 Diagramme du cylindre à ressort  
 Diagramma del freno di servizio

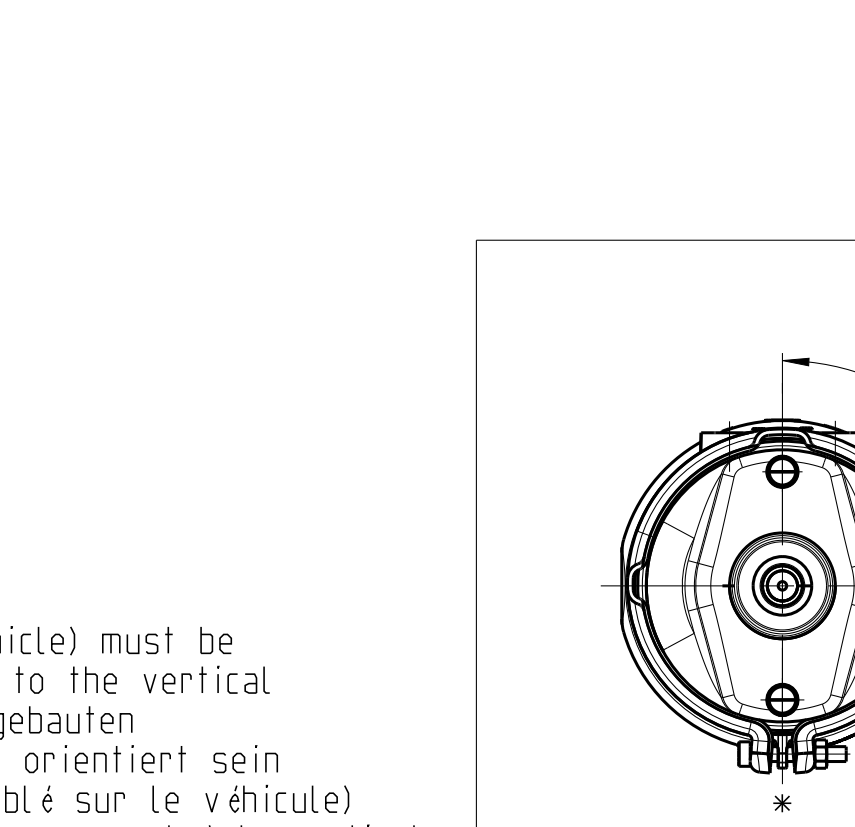

Force at piston rod  
 Kraft an der Kolbenstange  
 Effort à la tige de piston  
 Forza esercitata sul puntale

BS9283 - K001976		6.8																																								
KB-Ref. number	KB-Bestell-Nr.	Weight																																								
KB-N° de ref.	KB Codice	Mass																																								
		Peso (kg)																																								
<table border="1"> <thead> <tr> <th>Rev.</th> <th>Revision Reference</th> <th>Date</th> <th>Name</th> <th>Special Characteristics</th> <th>Surface Treatment</th> <th>Length Unit</th> <th>mm</th> <th>Scale</th> <th>1:1</th> </tr> </thead> <tbody> <tr> <td>003</td> <td>C0007076</td> <td>10.04.2024</td> <td>50</td> <td></td> <td></td> <td></td> <td></td> <td></td> <td></td> </tr> </tbody> </table>			Rev.	Revision Reference	Date	Name	Special Characteristics	Surface Treatment	Length Unit	mm	Scale	1:1	003	C0007076	10.04.2024	50																										
Rev.	Revision Reference	Date	Name	Special Characteristics	Surface Treatment	Length Unit	mm	Scale	1:1																																	
003	C0007076	10.04.2024	50																																							
<table border="1"> <thead> <tr> <th>Rev.</th> <th>ISO 103-30</th> <th>ISO 103-30</th> <th>ISO 103-30</th> <th>ISO 103-30</th> <th>ISO 103-30</th> <th>ISO 103-30</th> <th>ISO 103-30</th> <th>ISO 103-30</th> <th>ISO 103-30</th> </tr> </thead> <tbody> <tr> <td>+</td> <td>+</td> <td>+</td> <td>+</td> <td>+</td> <td>+</td> <td>+</td> <td>+</td> <td>+</td> <td>+</td> </tr> <tr> <td>-</td> <td>-</td> <td>-</td> <td>-</td> <td>-</td> <td>-</td> <td>-</td> <td>-</td> <td>-</td> <td>-</td> </tr> <tr> <td>0</td> <td>0</td> <td>0</td> <td>0</td> <td>0</td> <td>0</td> <td>0</td> <td>0</td> <td>0</td> <td>0</td> </tr> </tbody> </table>			Rev.	ISO 103-30	ISO 103-30	ISO 103-30	ISO 103-30	ISO 103-30	ISO 103-30	ISO 103-30	ISO 103-30	ISO 103-30	+	+	+	+	+	+	+	+	+	+	-	-	-	-	-	-	-	-	-	-	0	0	0	0	0	0	0	0	0	0
Rev.	ISO 103-30	ISO 103-30	ISO 103-30	ISO 103-30	ISO 103-30	ISO 103-30	ISO 103-30	ISO 103-30	ISO 103-30																																	
+	+	+	+	+	+	+	+	+	+																																	
-	-	-	-	-	-	-	-	-	-																																	
0	0	0	0	0	0	0	0	0	0																																	
<table border="1"> <thead> <tr> <th>Rev.</th> <th>ISO 103-30</th> <th>ISO 103-30</th> <th>ISO 103-30</th> <th>ISO 103-30</th> <th>ISO 103-30</th> <th>ISO 103-30</th> <th>ISO 103-30</th> <th>ISO 103-30</th> <th>ISO 103-30</th> </tr> </thead> <tbody> <tr> <td>+</td> <td>+</td> <td>+</td> <td>+</td> <td>+</td> <td>+</td> <td>+</td> <td>+</td> <td>+</td> <td>+</td> </tr> <tr> <td>-</td> <td>-</td> <td>-</td> <td>-</td> <td>-</td> <td>-</td> <td>-</td> <td>-</td> <td>-</td> <td>-</td> </tr> <tr> <td>0</td> <td>0</td> <td>0</td> <td>0</td> <td>0</td> <td>0</td> <td>0</td> <td>0</td> <td>0</td> <td>0</td> </tr> </tbody> </table>			Rev.	ISO 103-30	ISO 103-30	ISO 103-30	ISO 103-30	ISO 103-30	ISO 103-30	ISO 103-30	ISO 103-30	ISO 103-30	+	+	+	+	+	+	+	+	+	+	-	-	-	-	-	-	-	-	-	-	0	0	0	0	0	0	0	0	0	0
Rev.	ISO 103-30	ISO 103-30	ISO 103-30	ISO 103-30	ISO 103-30	ISO 103-30	ISO 103-30	ISO 103-30	ISO 103-30																																	
+	+	+	+	+	+	+	+	+	+																																	
-	-	-	-	-	-	-	-	-	-																																	
0	0	0	0	0	0	0	0	0	0																																	
<table border="1"> <thead> <tr> <th>Rev.</th> <th>ISO 103-30</th> <th>ISO 103-30</th> <th>ISO 103-30</th> <th>ISO 103-30</th> <th>ISO 103-30</th> <th>ISO 103-30</th> <th>ISO 103-30</th> <th>ISO 103-30</th> <th>ISO 103-30</th> </tr> </thead> <tbody> <tr> <td>+</td> <td>+</td> <td>+</td> <td>+</td> <td>+</td> <td>+</td> <td>+</td> <td>+</td> <td>+</td> <td>+</td> </tr> <tr> <td>-</td> <td>-</td> <td>-</td> <td>-</td> <td>-</td> <td>-</td> <td>-</td> <td>-</td> <td>-</td> <td>-</td> </tr> <tr> <td>0</td> <td>0</td> <td>0</td> <td>0</td> <td>0</td> <td>0</td> <td>0</td> <td>0</td> <td>0</td> <td>0</td> </tr> </tbody> </table>			Rev.	ISO 103-30	ISO 103-30	ISO 103-30	ISO 103-30	ISO 103-30	ISO 103-30	ISO 103-30	ISO 103-30	ISO 103-30	+	+	+	+	+	+	+	+	+	+	-	-	-	-	-	-	-	-	-	-	0	0	0	0	0	0	0	0	0	0
Rev.	ISO 103-30	ISO 103-30	ISO 103-30	ISO 103-30	ISO 103-30	ISO 103-30	ISO 103-30	ISO 103-30	ISO 103-30																																	
+	+	+	+	+	+	+	+	+	+																																	
-	-	-	-	-	-	-	-	-	-																																	
0	0	0	0	0	0	0	0	0	0																																	
<table border="1"> <thead> <tr> <th>Rev.</th> <th>ISO 103-30</th> <th>ISO 103-30</th> <th>ISO 103-30</th> <th>ISO 103-30</th> <th>ISO 103-30</th> <th>ISO 103-30</th> <th>ISO 103-30</th> <th>ISO 103-30</th> <th>ISO 103-30</th> </tr> </thead> <tbody> <tr> <td>+</td> <td>+</td> <td>+</td> <td>+</td> <td>+</td> <td>+</td> <td>+</td> <td>+</td> <td>+</td> <td>+</td> </tr> <tr> <td>-</td> <td>-</td> <td>-</td> <td>-</td> <td>-</td> <td>-</td> <td>-</td> <td>-</td> <td>-</td> <td>-</td> </tr> <tr> <td>0</td> <td>0</td> <td>0</td> <td>0</td> <td>0</td> <td>0</td> <td>0</td> <td>0</td> <td>0</td> <td>0</td> </tr> </tbody> </table>			Rev.	ISO 103-30	ISO 103-30	ISO 103-30	ISO 103-30	ISO 103-30	ISO 103-30	ISO 103-30	ISO 103-30	ISO 103-30	+	+	+	+	+	+	+	+	+	+	-	-	-	-	-	-	-	-	-	-	0	0	0	0	0	0	0	0	0	0
Rev.	ISO 103-30	ISO 103-30	ISO 103-30	ISO 103-30	ISO 103-30	ISO 103-30	ISO 103-30	ISO 103-30	ISO 103-30																																	
+	+	+	+	+	+	+	+	+	+																																	
-	-	-	-	-	-	-	-	-	-																																	
0	0	0	0	0	0	0	0	0	0																																	
<table border="1"> <thead> <tr> <th>Rev.</th> <th>ISO 103-30</th> <th>ISO 103-30</th> <th>ISO 103-30</th> <th>ISO 103-30</th> <th>ISO 103-30</th> <th>ISO 103-30</th> <th>ISO 103-30</th> <th>ISO 103-30</th> <th>ISO 103-30</th> </tr> </thead> <tbody> <tr> <td>+</td> <td>+</td> <td>+</td> <td>+</td> <td>+</td> <td>+</td> <td>+</td> <td>+</td> <td>+</td> <td>+</td> </tr> <tr> <td>-</td> <td>-</td> <td>-</td> <td>-</td> <td>-</td> <td>-</td> <td>-</td> <td>-</td> <td>-</td> <td>-</td> </tr> <tr> <td>0</td> <td>0</td> <td>0</td> <td>0</td> <td>0</td> <td>0</td> <td>0</td> <td>0</td> <td>0</td> <td>0</td> </tr> </tbody> </table>			Rev.	ISO 103-30	ISO 103-30	ISO 103-30	ISO 103-30	ISO 103-30	ISO 103-30	ISO 103-30	ISO 103-30	ISO 103-30	+	+	+	+	+	+	+	+	+	+	-	-	-	-	-	-	-	-	-	-	0	0	0	0	0	0	0	0	0	0
Rev.	ISO 103-30	ISO 103-30	ISO 103-30	ISO 103-30	ISO 103-30	ISO 103-30	ISO 103-30	ISO 103-30	ISO 103-30																																	
+	+	+	+	+	+	+	+	+	+																																	
-	-	-	-	-	-	-	-	-	-																																	
0	0	0	0	0	0	0	0	0	0																																	
<table border="1"> <thead> <tr> <th>Rev.</th> <th>ISO 103-30</th> <th>ISO 103-30</th> <th>ISO 103-30</th> <th>ISO 103-30</th> <th>ISO 103-30</th> <th>ISO 103-30</th> <th>ISO 103-30</th> <th>ISO 103-30</th> <th>ISO 103-30</th> </tr> </thead> <tbody> <tr> <td>+</td> <td>+</td> <td>+</td> <td>+</td> <td>+</td> <td>+</td> <td>+</td> <td>+</td> <td>+</td> <td>+</td> </tr> <tr> <td>-</td> <td>-</td> <td>-</td> <td>-</td> <td>-</td> <td>-</td> <td>-</td> <td>-</td> <td>-</td> <td>-</td> </tr> <tr> <td>0</td> <td>0</td> <td>0</td> <td>0</td> <td>0</td> <td>0</td> <td>0</td> <td>0</td> <td>0</td> <td>0</td> </tr> </tbody> </table>			Rev.	ISO 103-30	ISO 103-30	ISO 103-30	ISO 103-30	ISO 103-30	ISO 103-30	ISO 103-30	ISO 103-30	ISO 103-30	+	+	+	+	+	+	+	+	+	+	-	-	-	-	-	-	-	-	-	-	0	0	0	0	0	0	0	0	0	0
Rev.	ISO 103-30	ISO 103-30	ISO 103-30	ISO 103-30	ISO 103-30	ISO 103-30	ISO 103-30	ISO 103-30	ISO 103-30																																	
+	+	+	+	+	+	+	+	+	+																																	
-	-	-	-	-	-	-	-	-	-																																	
0	0	0	0	0	0	0	0	0	0																																	
<table border="1"> <thead> <tr> <th>Rev.</th> <th>ISO 103-30</th> <th>ISO 103-30</th> <th>ISO 103-30</th> <th>ISO 103-30</th> <th>ISO 103-30</th> <th>ISO 103-30</th> <th>ISO 103-30</th> <th>ISO 103-30</th> <th>ISO 103-30</th> </tr> </thead> <tbody> <tr> <td>+</td> <td>+</td> <td>+</td> <td>+</td> <td>+</td> <td>+</td> <td>+</td> <td>+</td> <td>+</td> <td>+</td> </tr> <tr> <td>-</td> <td>-</td> <td>-</td> <td>-</td> <td>-</td> <td>-</td> <td>-</td> <td>-</td> <td>-</td> <td>-</td> </tr> <tr> <td>0</td> <td>0</td> <td>0</td> <td>0</td> <td>0</td> <td>0</td> <td>0</td> <td>0</td> <td>0</td> <td>0</td> </tr> </tbody> </table>			Rev.	ISO 103-30	ISO 103-30	ISO 103-30	ISO 103-30	ISO 103-30	ISO 103-30	ISO 103-30	ISO 103-30	ISO 103-30	+	+	+	+	+	+	+	+	+	+	-	-	-	-	-	-	-	-	-	-	0	0	0	0	0	0	0	0	0	0
Rev.	ISO 103-30	ISO 103-30	ISO 103-30	ISO 103-30	ISO 103-30	ISO 103-30	ISO 103-30	ISO 103-30	ISO 103-30																																	
+	+	+	+	+	+	+	+	+	+																																	
-	-	-	-	-	-	-	-	-	-																																	
0	0	0	0	0	0	0	0	0	0																																	
<table border="1"> <thead> <tr> <th>Rev.</th> <th>ISO 103-30</th> <th>ISO 103-30</th> <th>ISO 103-30</th> <th>ISO 103-30</th> <th>ISO 103-30</th> <th>ISO 103-30</th> <th>ISO 103-30</th> <th>ISO 103-30</th> <th>ISO 103-30</th> </tr> </thead> <tbody> <tr> <td>+</td> <td>+</td> <td>+</td> <td>+</td> <td>+</td> <td>+</td> <td>+</td> <td>+</td> <td>+</td> <td>+</td> </tr> <tr> <td>-</td> <td>-</td> <td>-</td> <td>-</td> <td>-</td> <td>-</td> <td>-</td> <td>-</td> <td>-</td> <td>-</td> </tr> <tr> <td>0</td> <td>0</td> <td>0</td> <td>0</td> <td>0</td> <td>0</td> <td>0</td> <td>0</td> <td>0</td> <td>0</td> </tr> </tbody> </table>			Rev.	ISO 103-30	ISO 103-30	ISO 103-30	ISO 103-30	ISO 103-30	ISO 103-30	ISO 103-30	ISO 103-30	ISO 103-30	+	+	+	+	+	+	+	+	+	+	-	-	-	-	-	-	-	-	-	-	0	0	0	0	0	0	0	0	0	0
Rev.	ISO 103-30	ISO 103-30	ISO 103-30	ISO 103-30	ISO 103-30	ISO 103-30	ISO 103-30	ISO 103-30	ISO 103-30																																	
+	+	+	+	+	+	+	+	+	+																																	
-	-	-	-	-	-	-	-	-	-																																	
0	0	0	0	0	0	0	0	0	0																																	
<table border="1"> <thead> <tr> <th>Rev.</th> <th>ISO 103-30</th> <th>ISO 103-30</th> <th>ISO 103-30</th> <th>ISO 103-30</th> <th>ISO 103-30</th> <th>ISO 103-30</th> <th>ISO 103-30</th> <th>ISO 103-30</th> <th>ISO 103-30</th> </tr> </thead> <tbody> <tr> <td>+</td> <td>+</td> <td>+</td> <td>+</td> <td>+</td> <td>+</td> <td>+</td> <td>+</td> <td>+</td> <td>+</td> </tr> <tr> <td>-</td> <td>-</td> <td>-</td> <td>-</td> <td>-</td> <td>-</td> <td>-</td> <td>-</td> <td>-</td> <td>-</td> </tr> <tr> <td>0</td> <td>0</td> <td>0</td> <td>0</td> <td>0</td> <td>0</td> <td>0</td> <td>0</td> <td>0</td> <td>0</td> </tr> </tbody> </table>			Rev.	ISO 103-30	ISO 103-30	ISO 103-30	ISO 103-30	ISO 103-30	ISO 103-30	ISO 103-30	ISO 103-30	ISO 103-30	+	+	+	+	+	+	+	+	+	+	-	-	-	-	-	-	-	-	-	-	0	0	0	0	0	0	0	0	0	0
Rev.	ISO 103-30	ISO 103-30	ISO 103-30	ISO 103-30	ISO 103-30	ISO 103-30	ISO 103-30	ISO 103-30	ISO 103-30																																	
+	+	+	+	+	+	+	+	+	+																																	
-	-	-	-	-	-	-	-	-	-																																	
0	0	0	0	0	0	0	0	0	0																																	
<table border="1"> <thead> <tr> <th>Rev.</th> <th>ISO 103-30</th> <th>ISO 103-30</th> <th>ISO 103-30</th> <th>ISO 103-30</th> <th>ISO 103-30</th> <th>ISO 103-30</th> <th>ISO 103-30</th> <th>ISO 103-30</th> <th>ISO 103-30</th> </tr> </thead> <tbody> <tr> <td>+</td> <td>+</td> <td>+</td> <td>+</td> <td>+</td> <td>+</td> <td>+</td> <td>+</td> <td>+</td> <td>+</td> </tr> <tr> <td>-</td> <td>-</td> <td>-</td> <td>-</td> <td>-</td> <td>-</td> <td>-</td> <td>-</td> <td>-</td> <td>-</td> </tr> <tr> <td>0</td> <td>0</td> <td>0</td> <td>0</td> <td>0</td> <td>0</td> <td>0</td> <td>0</td> <td>0</td> <td>0</td> </tr> </tbody> </table>			Rev.	ISO 103-30	ISO 103-30	ISO 103-30	ISO 103-30	ISO 103-30	ISO 103-30	ISO 103-30	ISO 103-30	ISO 103-30	+	+	+	+	+	+	+	+	+	+	-	-	-	-	-	-	-	-	-	-	0	0	0	0	0	0	0	0	0	0
Rev.	ISO 103-30	ISO 103-30	ISO 103-30	ISO 103-30	ISO 103-30	ISO 103-30	ISO 103-30	ISO 103-30	ISO 103-30																																	
+	+	+	+	+	+	+	+	+	+																																	
-	-	-	-	-	-	-	-	-	-																																	
0	0	0	0	0	0	0	0	0	0																																	
<table border="1"> <thead> <tr> <th>Rev.</th> <th>ISO 103-30</th> <th>ISO 103-30</th> <th>ISO 103-30</th> <th>ISO 103-30</th> <th>ISO 103-30</th> <th>ISO 103-30</th> <th>ISO 103-30</th> <th>ISO 103-30</th> <th>ISO 103-30</th> </tr> </thead> <tbody> <tr> <td>+</td> <td>+</td> <td>+</td> <td>+</td> <td>+</td> <td>+</td> <td>+</td> <td>+</td> <td>+</td> <td>+</td> </tr> <tr> <td>-</td> <td>-</td> <td>-</td> <td>-</td> <td>-</td> <td>-</td> <td>-</td> <td>-</td> <td>-</td> <td>-</td> </tr> <tr> <td>0</td> <td>0</td> <td>0</td> <td>0</td> <td>0</td> <td>0</td> <td>0</td> <td>0</td> <td>0</td> <td>0</td> </tr> </tbody> </table>			Rev.	ISO 103-30	ISO 103-30	ISO 103-30	ISO 103-30	ISO 103-30	ISO 103-30	ISO 103-30	ISO 103-30	ISO 103-30	+	+	+	+	+	+	+	+	+	+	-	-	-	-	-	-	-	-	-	-	0	0	0	0	0	0	0	0	0	0
Rev.	ISO 103-30	ISO 103-30	ISO 103-30	ISO 103-30	ISO 103-30	ISO 103-30	ISO 103-30	ISO 103-30	ISO 103-30																																	
+	+	+	+	+	+	+	+	+	+																																	
-	-	-	-	-	-	-	-	-	-																																	
0	0	0	0	0	0	0	0	0	0																																	
<table border="1"> <thead> <tr> <th>Rev.</th> <th>ISO 103-30</th> <th>ISO 103-30</th> <th>ISO 103-30</th> <th>ISO 103-30</th> <th>ISO 103-30</th> <th>ISO 103-30</th> <th>ISO 103-30</th> <th>ISO 103-30</th> <th>ISO 103-30</th> </tr> </thead> <tbody> <tr> <td>+</td> <td>+</td> <td>+</td> <td>+</td> <td>+</td> <td>+</td> <td>+</td> <td>+</td> <td>+</td> <td>+</td> </tr> <tr> <td>-</td> <td>-</td> <td>-</td> <td>-</td> <td>-</td> <td>-</td> <td>-</td> <td>-</td> <td>-</td> <td>-</td> </tr> <tr> <td>0</td> <td>0</td> <td>0</td> <td>0</td> <td>0</td> <td>0</td> <td>0</td> <td>0</td> <td>0</td> <td>0</td> </tr> </tbody> </table>			Rev.	ISO 103-30	ISO 103-30	ISO 103-30	ISO 103-30	ISO 103-30	ISO 103-30	ISO 103-30	ISO 103-30	ISO 103-30	+	+	+	+	+	+	+	+	+	+	-	-	-	-	-	-	-	-	-	-	0	0	0	0	0	0	0	0	0	0
Rev.	ISO 103-30	ISO 103-30	ISO 103-30	ISO 103-30	ISO 103-30	ISO 103-30	ISO 103-30	ISO 103-30	ISO 103-30																																	
+	+	+	+	+	+	+	+	+	+																																	
-	-	-	-	-	-	-	-	-	-																																	
0	0	0	0	0	0	0	0	0	0																																	
<table border="1"> <thead> <tr> <th>Rev.</th> <th>ISO 103-30</th> <th>ISO 103-30</th> <th>ISO 103-30</th> <th>ISO 103-30</th> <th>ISO 103-30</th> <th>ISO 103-30</th> <th>ISO 103-30</th> <th>ISO 103-30</th> <th>ISO 103-30</th> </tr> </thead> <tbody> <tr> <td>+</td> <td>+</td> <td>+</td> <td>+</td> <td>+</td> <td>+</td> <td>+</td> <td>+</td> <td>+</td> <td>+</td> </tr> <tr> <td>-</td> <td>-</td> <td>-</td> <td>-</td> <td>-</td> <td>-</td> <td>-</td> <td>-</td> <td>-</td> <td>-</td> </tr> <tr> <td>0</td> <td>0</td> <td>0</td> <td>0</td> <td>0</td> <td>0</td> <td>0</td> <td>0</td> <td>0</td> <td>0</td> </tr> </tbody> </table>			Rev.	ISO 103-30	ISO 103-30	ISO 103-30	ISO 103-30	ISO 103-30	ISO 103-30	ISO 103-30	ISO 103-30	ISO 103-30	+	+	+	+	+	+	+	+	+	+	-	-	-	-	-	-	-	-	-	-	0	0	0	0	0	0	0	0	0	0
Rev.	ISO 103-30	ISO 103-30	ISO 103-30	ISO 103-30	ISO 103-30	ISO 103-30	ISO 103-30	ISO 103-30	ISO 103-30																																	
+	+	+	+	+	+	+	+	+	+																																	
-	-	-	-	-	-	-	-	-	-																																	
0	0	0	0	0	0	0	0	0	0																																	
<table border="1"> <thead> <tr> <th>Rev.</th> <th>ISO 103-30</th> <th>ISO 103-30</th> <th>ISO 103-30</th> <th>ISO 103-30</th> <th>ISO 103-30</th> <th>ISO 103-30</th> <th>ISO 103-30</th> <th>ISO 103-30</th> <th>ISO 103-30</th> </tr> </thead> <tbody> <tr> <td>+</td> <td>+</td> <td>+</td> <td>+</td> <td>+</td> <td>+</td> <td>+</td> <td>+</td> <td>+</td> <td>+</td> </tr> <tr> <td>-</td> <td>-</td> <td>-</td> <td>-</td> <td>-</td> <td>-</td> <td>-</td> <td>-</td> <td>-</td> <td>-</td> </tr> <tr> <td>0</td> <td>0</td> <td>0</td> <td>0</td> <td>0</td> <td>0</td> <td>0</td> <td>0</td> <td>0</td> <td>0</td> </tr> </tbody> </table>			Rev.	ISO 103-30	ISO 103-30	ISO 103-30	ISO 103-30	ISO 103-30	ISO 103-30	ISO 103-30	ISO 103-30	ISO 103-30	+	+	+	+	+	+	+	+	+	+	-	-	-	-	-	-	-	-	-	-	0	0	0	0	0	0	0	0	0	0
Rev.	ISO 103-30	ISO 103-30	ISO 103-30	ISO 103-30	ISO 103-30	ISO 103-30	ISO 103-30	ISO 103-30	ISO 103-30																																	
+	+	+	+	+	+	+	+	+	+																																	
-	-	-	-	-	-	-	-	-	-																																	
0	0	0	0	0	0	0	0	0	0																																	
<table border="1"> <thead> <tr> <th>Rev.</th> <th>ISO 103-30</th> <th>ISO 103-30</th> <th>ISO 103-30</th> <th>ISO 103-30</th> <th>ISO 103-30</th> <th>ISO 103-30</th> <th>ISO 103-30</th> <th>ISO 103-30</th> <th>ISO 103-30</th> </tr> </thead> <tbody> <tr> <td>+</td> <td>+</td> <td>+</td> <td>+</td> <td>+</td> <td>+</td> <td>+</td> <td>+</td> <td>+</td> <td>+</td> </tr> <tr> <td>-</td> <td>-</td> <td>-</td> <td>-</td> <td>-</td> <td>-</td> <td>-</td> <td>-</td> <td>-</td> <td>-</td> </tr> <tr> <td>0</td> <td>0</td> <td>0</td> <td>0</td> <td>0</td> <td>0</td> <td>0</td> <td>0</td> <td>0</td> <td>0</td> </tr> </tbody> </table>			Rev.	ISO 103-30	ISO 103-30	ISO 103-30	ISO 103-30	ISO 103-30	ISO 103-30	ISO 103-30	ISO 103-30	ISO 103-30	+	+	+	+	+	+	+	+	+	+	-	-	-	-	-	-	-	-	-	-	0	0	0	0	0	0	0	0	0	0
Rev.	ISO 103-30	ISO 103-30	ISO 103-30	ISO 103-30	ISO 103-30	ISO 103-30	ISO 103-30	ISO 103-30	ISO 103-30																																	
+	+	+	+	+	+	+	+	+	+																																	
-	-	-	-	-	-	-	-	-	-																																	
0	0	0	0	0	0	0	0	0	0																																	
<table border="1"> <thead> <tr> <th>Rev.</th> <th>ISO 103-30</th> <th>ISO 103-30</th> <th>ISO 103-30</th> <th>ISO 103-30</th> <th>ISO 103-30</th> <th>ISO 103-30</th> <th>ISO 103-30</th> <th>ISO 103-30</th> <th>ISO 103-30</th> </tr> </thead> <tbody> <tr> <td>+</td> <td>+</td> <td>+</td> <td>+</td> <td>+</td> <td>+</td> <td>+</td> <td>+</td> <td>+</td> <td>+</td> </tr> <tr> <td>-</td> <td>-</td> <td>-</td> <td>-</td> <td>-</td> <td>-</td> <td>-</td> <td>-</td> <td>-</td> <td>-</td> </tr> <tr> <td>0</td> <td>0</td> <td>0</td> <td>0</td> <td>0</td> <td>0</td> <td>0</td> <td>0</td> <td>0</td> <td>0</td> </tr> </tbody> </table>			Rev.	ISO 103-30	ISO 103-30	ISO 103-30	ISO 103-30	ISO 103-30	ISO 103-30	ISO 103-30	ISO 103-30	ISO 103-30	+	+	+	+	+	+	+	+	+	+	-	-	-	-	-	-	-	-	-	-	0	0	0	0	0	0	0	0	0	0
Rev.	ISO 103-30	ISO 103-30	ISO 103-30	ISO 103-30	ISO 103-30	ISO 103-30	ISO 103-30	ISO 103-30	ISO 103-30																																	
+	+	+	+	+	+	+	+	+	+																																	
-	-	-	-	-	-	-	-	-	-																																	
0	0	0	0	0	0	0	0	0	0																																	
<table border="1"> <thead> <tr> <th>Rev.</th> <th>ISO 103-30</th> <th>ISO 103-30</th> <th>ISO 103-30</th> <th>ISO 103-30</th> <th>ISO 103-30</th> <th>ISO 103-30</th> <th>ISO 103-30</th> <th>ISO 103-30</th> <th>ISO 103-30</th> </tr> </thead> <tbody> <tr> <td>+</td> <td>+</td> <td>+</td> <td>+</td> <td>+</td> <td>+</td> <td>+</td> <td>+</td> <td>+</td> <td>+</td> </tr> <tr> <td>-</td> <td>-</td> <td>-</td> <td>-</td> <td>-</td> <td>-</td> <td>-</td> <td>-</td> <td>-</td> <td>-</td> </tr> <tr> <td>0</td> <td>0</td> <td>0</td> <td>0</td> <td>0</td> <td>0</td> <td>0</td> <td>0</td> <td>0</td> <td>0</td> </tr> </tbody> </table>			Rev.	ISO 103-30	ISO 103-30	ISO 103-30	ISO 103-30	ISO 103-30	ISO 103-30	ISO 103-30	ISO 103-30	ISO 103-30	+	+	+	+	+	+	+	+	+	+	-	-	-	-	-	-	-	-	-	-	0	0	0	0	0	0	0	0	0	0
Rev.	ISO 103-30	ISO 103-30	ISO 103-30	ISO 103-30	ISO 103-30	ISO 103-30	ISO 103-30	ISO 103-30	ISO 103-30																																	
+	+	+	+	+	+	+	+	+	+																																	
-	-	-	-	-	-	-	-	-	-																																	
0	0	0	0	0	0	0	0	0	0																																	
<table border="1"> <thead> <tr> <th>Rev.</th> <th>ISO 103-30</th> <th>ISO 103-30</th> <th>ISO 103-30</th> <th>ISO 103-30</th> <th>ISO 103-30</th> <th>ISO 103-30</th> <th>ISO 103-30</th> <th>ISO 103-30</th> <th>ISO 103-30</th> </tr> </thead> <tbody> <tr> <td>+</td> <td>+</td> <td>+</td> <td>+</td> <td>+</td> <td>+</td> <td>+</td> <td>+</td> <td>+</td> <td>+</td> </tr> <tr> <td>-</td> <td>-</td> <td>-</td> <td>-</td> <td>-</td> <td>-</td> <td>-</td> <td>-</td> <td>-</td> <td>-</td> </tr> <tr> <td>0</td> <td>0</td> <td>0</td> <td>0</td> <td>0</td> <td>0</td> <td>0</td> <td>0</td> <td>0</td> <td>0</td> </tr> </tbody> </table>			Rev.	ISO 103-30	ISO 103-30	ISO 103-30	ISO 103-30	ISO 103-30	ISO 103-30	ISO 103-30	ISO 103-30	ISO 103-30	+	+	+	+	+	+	+	+	+	+	-	-	-	-	-	-	-	-	-	-	0	0	0	0	0	0	0	0	0	0
Rev.	ISO 103-30	ISO 103-30	ISO 103-30	ISO 103-30	ISO 103-30	ISO 103-30	ISO 103-30	ISO 103-30	ISO 103-30																																	
+	+	+	+	+	+	+	+	+	+																																	
-	-	-	-	-	-	-	-	-	-																																	
0	0	0	0	0	0	0	0	0	0																																	
<table border="1"> <thead> <tr> <th>Rev.</th> <th>ISO 103-30</th> <th>ISO 103-30</th> <th>ISO 103-30</th> <th>ISO 103-30</th> <th>ISO 103-30</th> <th>ISO 103-30</th> <th>ISO 103-30</th> <th>ISO 103-30</th> <th>ISO 103-30</th> </tr> </thead> <tbody> <tr> <td>+</td> <td>+</td> <td>+</td> <td>+</td> <td>+</td> <td>+</td> <td>+</td> <td>+</td> <td>+</td> <td>+</td> </tr> <tr> <td>-</td> <td>-</td> <td>-</td> <td>-</td> <td>-</td> <td>-</td> <td>-</td> <td>-</td> <td>-</td> <td>-</td> </tr> <tr> <td>0</td> <td>0</td> <td>0</td> <td>0</td> <td>0</td> <td>0</td> <td>0</td> <td>0</td> <td>0</td> <td>0</td> </tr> </tbody> </table>			Rev.	ISO 103-30	ISO 103-30	ISO 103-30	ISO 103-30	ISO 103-30	ISO 103-30	ISO 103-30	ISO 103-30	ISO 103-30	+	+	+	+	+	+	+	+	+	+	-	-	-	-	-	-	-	-	-	-	0	0	0	0	0	0	0	0	0	0
Rev.	ISO 103-30	ISO 103-30	ISO 103-30	ISO 103-30	ISO 103-30	ISO 103-30	ISO 103-30	ISO 103-30	ISO 103-30																																	
+	+	+	+	+	+	+	+	+	+																																	
-	-	-	-	-	-	-	-	-	-																																	
0	0	0	0	0	0	0	0	0	0																																	
<table border="1"> <thead> <tr> <th>Rev.</th> <th>ISO 103-30</th> <th>ISO 103-30</th> <th>ISO 103-30</th> <th>ISO 103-30</th> <th>ISO 103-30</th> <th>ISO 103-30</th> <th>ISO 103-30</th> <th>ISO 103-30</th> <th>ISO 103-30</th> </tr> </thead> <tbody> <tr> <td>+</td> <td>+</td> <td>+</td> <td>+</td> <td>+</td> <td>+</td> <td>+</td> <td>+</td> <td>+</td> <td>+</td> </tr> <tr> <td>-</td> <td>-</td> <td>-</td> <td>-</td> <td>-</td> <td>-</td> <td>-</td> <td>-</td> <td>-</td> <td>-</td> </tr> <tr> <td>0</td> <td>0</td> <td>0</td> <td>0</td> <td>0</td> <td>0</td> <td>0</td> <td>0</td> <td>0</td> <td>0</td> </tr> </tbody> </table>			Rev.	ISO 103-30	ISO 103-30	ISO 103-30	ISO 103-30	ISO 103-30	ISO 103-30	ISO 103-30	ISO 103-30	ISO 103-30	+	+	+	+	+	+	+	+	+	+	-	-	-	-	-	-	-	-	-	-	0	0	0	0	0	0	0	0	0	0
Rev.	ISO 103-30	ISO 103-30	ISO 103-30	ISO 103-30	ISO 103-30	ISO 103-30	ISO 103-30	ISO 103-30	ISO 103-30																																	
+	+	+	+	+	+	+	+	+	+																																	
-	-	-	-	-	-	-	-	-	-																																	
0	0	0	0	0	0	0	0	0	0																																	
<table border="1"> <thead> <tr> </tr></thead></table>																																										