



# Installation Instructions

## BENDIX SPRING BRAKE - PIGGYBACK REPLACEMENT

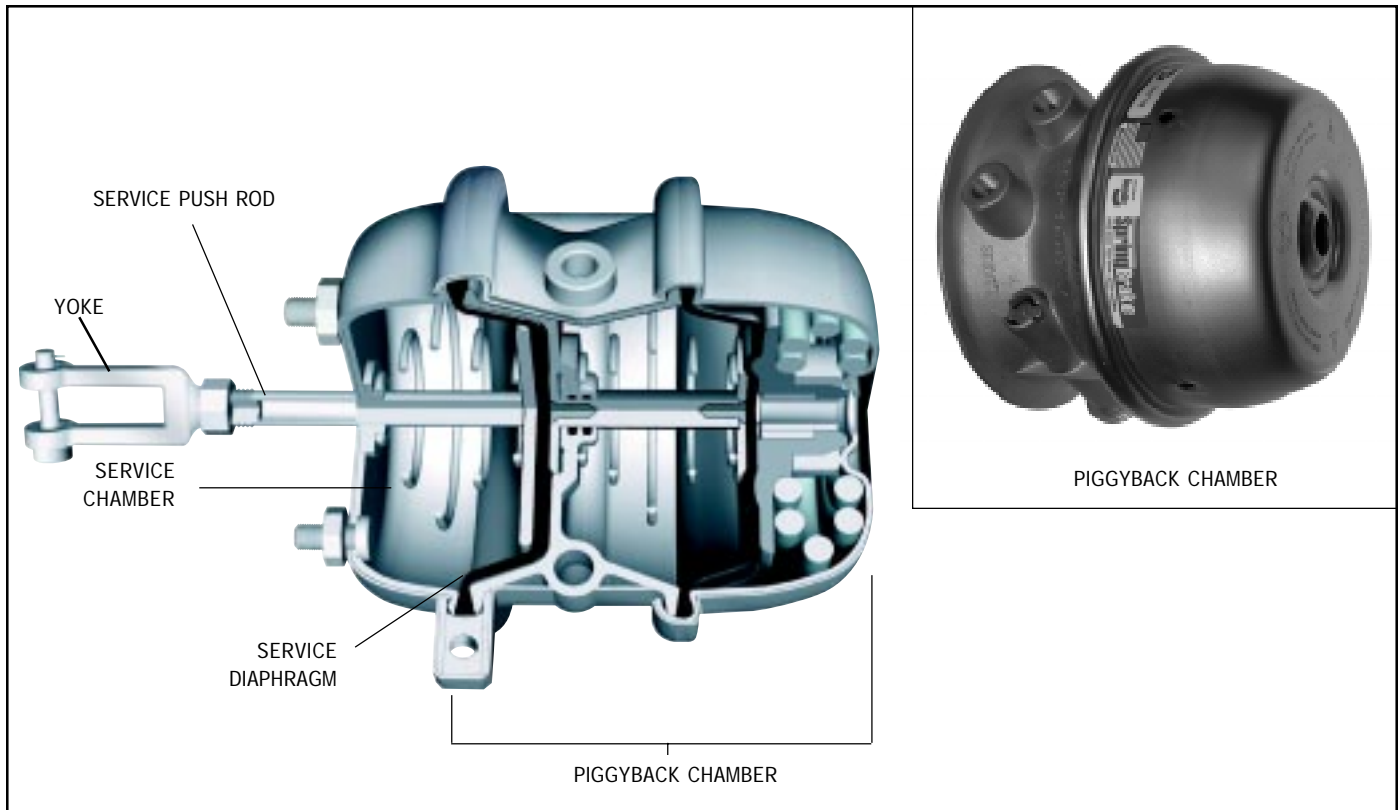

FIGURE 1 - BENDIX SPRING BRAKE

**IMPORTANT! PLEASE READ AND FOLLOW THESE INSTRUCTIONS TO AVOID PERSONAL INJURY OR DEATH:**

When working on or around a vehicle, the following general precautions should be observed at all times.

1. Park the vehicle on a level surface, apply the parking brakes, and always block the wheels.
2. Stop the engine when working around the vehicle.
3. If the vehicle is equipped with air brakes, make certain to drain the air pressure from all reservoirs before beginning ANY work on the vehicle.
4. Following the vehicle manufacturer's recommended procedures, deactivate the electrical system in manner that removes all electrical power from the vehicle.
5. When working in the engine compartment the engine should be shut off. Where circumstances require that the engine be in operation, **EXTREME CAUTION** should be used to prevent personal injury resulting from contact with moving, rotating, leaking, heated, or electrically charged components.
6. Never connect or disconnect a hose or line containing pressure; it may whip. Never remove a component or plug unless you are certain all system pressure has been depleted.
7. Never exceed recommended pressures and always wear safety glasses.
8. Do not attempt to install, remove, disassemble or assemble a component until you have read and thoroughly understand the recommended procedures. Use only the proper tools and observe all precautions pertaining to use of those tools.
9. Use only genuine Bendix replacement parts, components, and kits. Replacement hardware, tubing, hose, fittings, etc. should be of equivalent size, type, and strength as original equipment and be designed specifically for such applications and systems.
10. Components with stripped threads or damaged parts should be replaced rather than repaired. Repairs requiring machining or welding should not be attempted unless specifically approved and stated by the vehicle or component manufacturer.

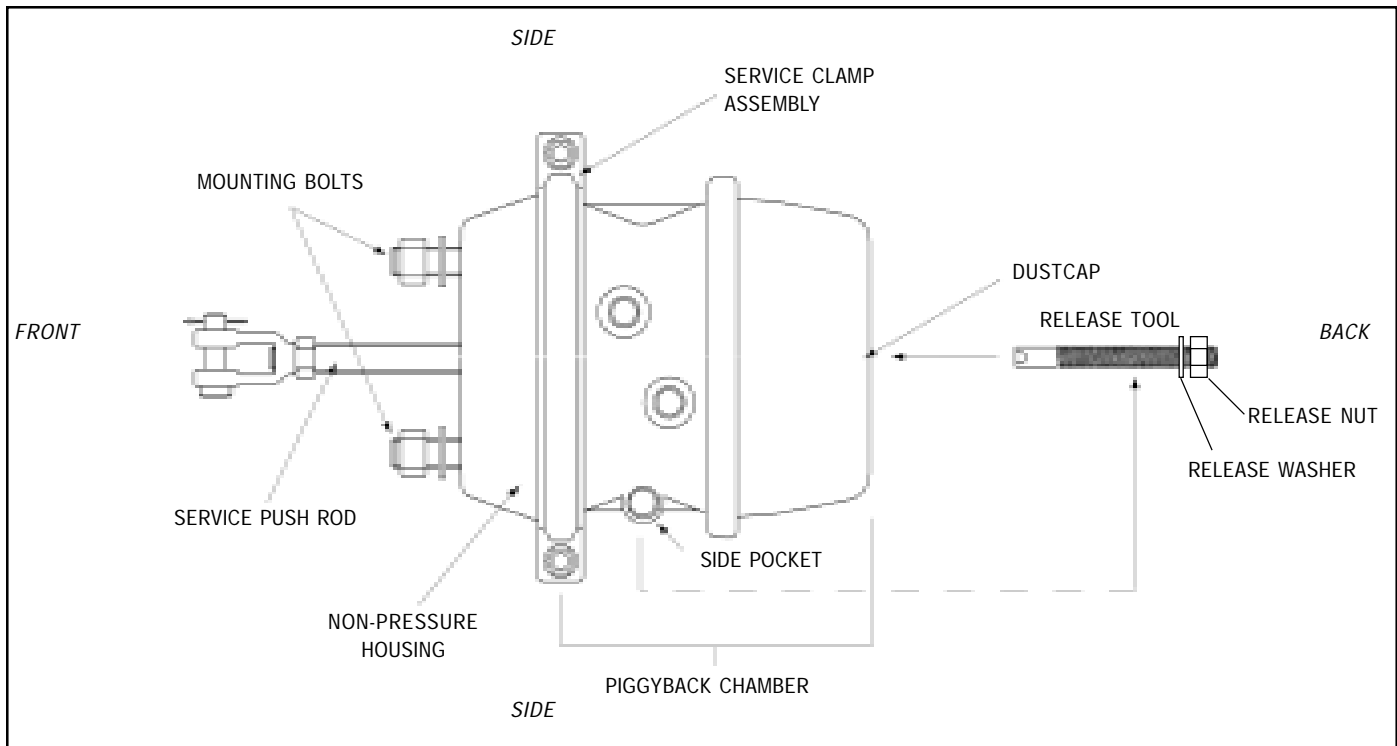

FIGURE 2 - BENDIX PIGGYBACK SPRING BRAKE

11. Prior to returning the vehicle to service, make certain all components and systems are restored to their proper operating condition.

#### KIT DESCRIPTION

This kit contains the Bendix Piggyback Spring Brake Chamber portion of the Spring Brake Assembly for service replacement.

#### **⚠ WARNING: ⚠**

- **Piggyback assemblies contain a loaded compression spring. Property damage, serious injury or death may occur if instructions are not followed completely.**
- **DO NOT service a spring brake chamber if it has structural damage of any kind. Replace the complete assembly. Dismount a damaged spring brake by first cutting the service pushrod with an acetylene torch to relieve any force it might have.**
- **Do not strike any part of a spring brake chamber for any reason. This may cause structural damage.**
- **Be careful not to drop a spring brake chamber at anytime. If dropped inspect for signs of structural damage. Replace complete assembly if damaged.**
- **The emergency diaphragm of a piggyback assembly cannot be replaced. Replace the whole piggyback spring brake assembly.**
- **Always work from the side of the spring brake chamber. Never work from the front or back.**

#### MECHANICAL RELEASE (CAGING) OF THE BENDIX PIGGYBACK SPRING BRAKE

#### **⚠ WARNING: ⚠**

**Do not mechanically release (cage) the spring if there is any structural damage to the actuator. Caging the spring in such a chamber may cause serious injury or death!**

#### **New Piggyback Assembly**

1. Remove the dust cap from the keyhole in the center of the piggyback spring brake chamber.
2. Remove the release tool assembly from the side pocket of the adaptor base.
3. Insert the release tool (T-bolt) through the release tool keyhole and into the pressure plate. See figure 3.
4. Turn the release tool 1/4 turn clockwise.
5. Pull on the release tool to seat it properly in the pressure plate .
6. Attach the release washer and nut.
7. To cage the main spring, tighten the release nut with a hand wrench and ensure the service pushrod is retracting.
8. Do not over torque the release tool assembly. Maximum torque is 35 ft/lbs.

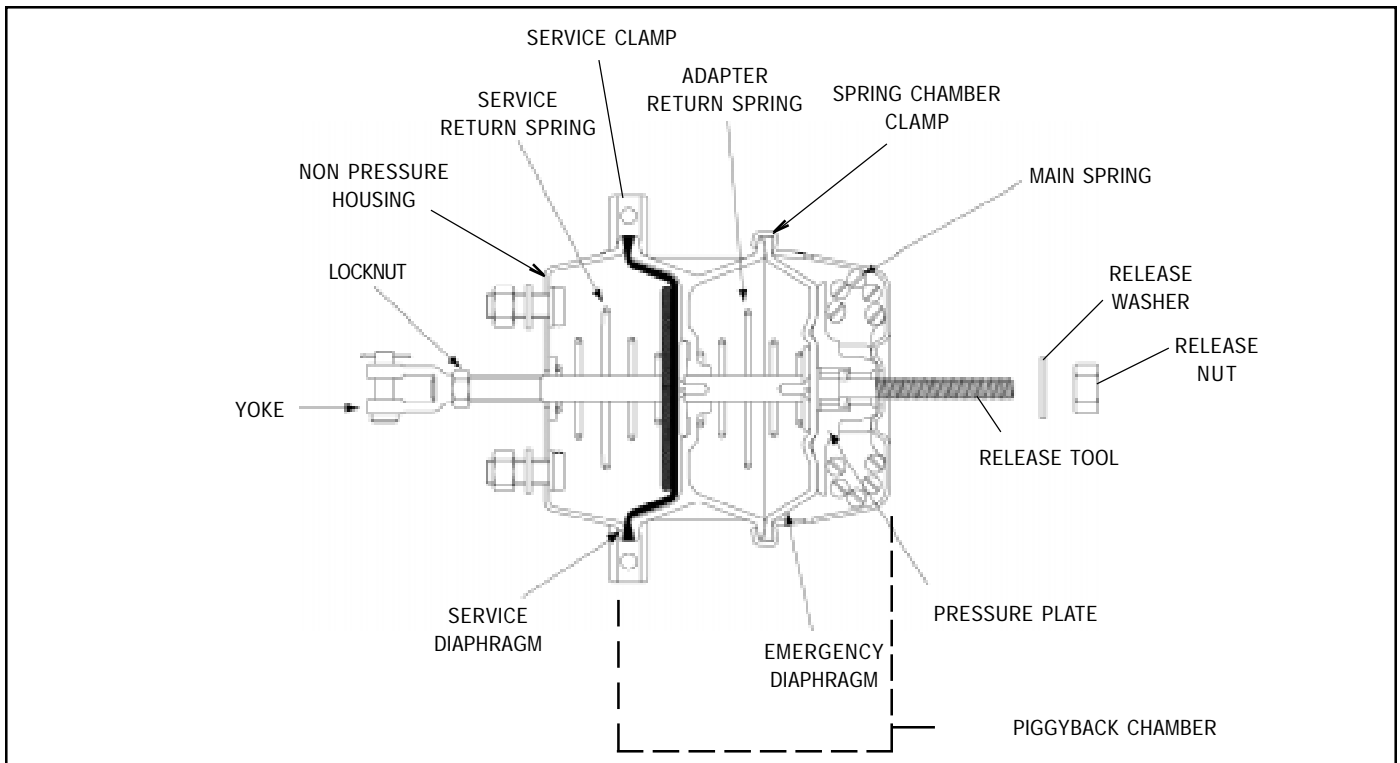

FIGURE 3 - BENDIX PIGGYBACK SPRING BRAKE

**⚠ WARNING: ⚠**

**Do not use an impact wrench. An impact wrench may over torque the release tool and cause damage to the pressure plate.**

9. The threaded portion of the release tool will extend approximately 2.9 inches out of the nut when fully released.

**INSTALLING THE BENDIX PIGGYBACK SPRING BRAKE CHAMBER**

*NOTE: The piggyback spring brake chamber can be replaced with the service brake chamber mounted to the vehicle or removed for ease of access.*

**⚠ WARNING: ⚠**

**Do not mechanically release (cage) the spring if there is any structural damage to the brake. Caging the spring in such a chamber may cause serious injury or death. Replace the complete spring brake assembly.**

1. Mechanically release the old piggyback spring brake by following the original manufacturer's instructions.
2. Ensure air pressure is removed from all air reservoirs before removing the air hoses or working on the spring brake.
3. Remove air hoses from the spring brake chamber. Be sure to mark both hoses to ensure proper reinstallation.

4. Clamp a pair of vise grips around the service push rod touching the non-pressure housing. This cages the service return spring.
5. If removal from the vehicle is necessary for servicing perform the following: Remove the yoke pin, disconnect the yoke from the slack adjuster, remove the mounting nuts, washers and lock washers. Remove the spring brake assembly using care to prevent the spring brake from falling.

**⚠ WARNING: ⚠**

**Do not remove the spring chamber clamps.**

6. Remove the clamp nuts and service clamp assembly and carefully remove the old piggyback chamber.
7. Visually inspect the service diaphragm for excessive wear, damage or cracks. Replace if needed.
8. Line up the new piggyback chamber, the service diaphragm, and the non-pressure housing, ensuring that they are centered.
9. Reassemble the service clamp assembly. Ensure all parts are seated properly and remain centered.
10. Torque the clamp nuts to 25 ft/lbs. Remove the vise grips from the service push rod.
11. If the assembly was removed: Install the spring brake assembly using the removed hardware. Torque the mounting nuts to 110 ft/lbs. Connect the yoke to the slack adjuster and install the yoke pin and the cotter pin.

12. Reconnect the emergency air line to the emergency port and reconnect the service air line to the service port.
13. Apply pressure to the service port of the spring brake. Do not exceed 150 psig. Test for leaks around the clamps. No leaks are acceptable.
14. Uncage the main spring and return the release tool into the release tool side pocket.
15. Replace the dust cap in the keyhole.



**Check for proper service and emergency operation after servicing any part of the brake chamber(s). Check the brake adjustment if the combination spring brake was removed/installed (Follow vehicle manufacturer's instructions to adjust the brakes).**

