

UP2DATE

EAC2.1 for DAF – Full service concept available now

Knorr-Bremse offers additional Air Dryer for DAF Air Treatment System.

As leading supplier for Air Treatment systems Knorr-Bremse supplies most of the commercial vehicle and bus manufacturers in Europe with systems to clean and dry the compressed air and by this assures a proper performance of the Air Braking system.

Since 2013 Knorr-Bremse supplies DAF with the EAC2.1. The modular design ensures an easy and cost-efficient service of the system. Meanwhile more than 450.000 DAF trucks are equipped with an EAC2.1.

With adding the Air Dryer K236770N50 to the Portfolio Knorr-Bremse is completing its Service Concept for the Independent Aftermarket.

At a glance

- › OE Quality
- › Best in class air drying performance with the OSC cartridge from Knorr-Bremse
- › Modular Service concept for easy and economical service



Aftermarket products for EAC2.1

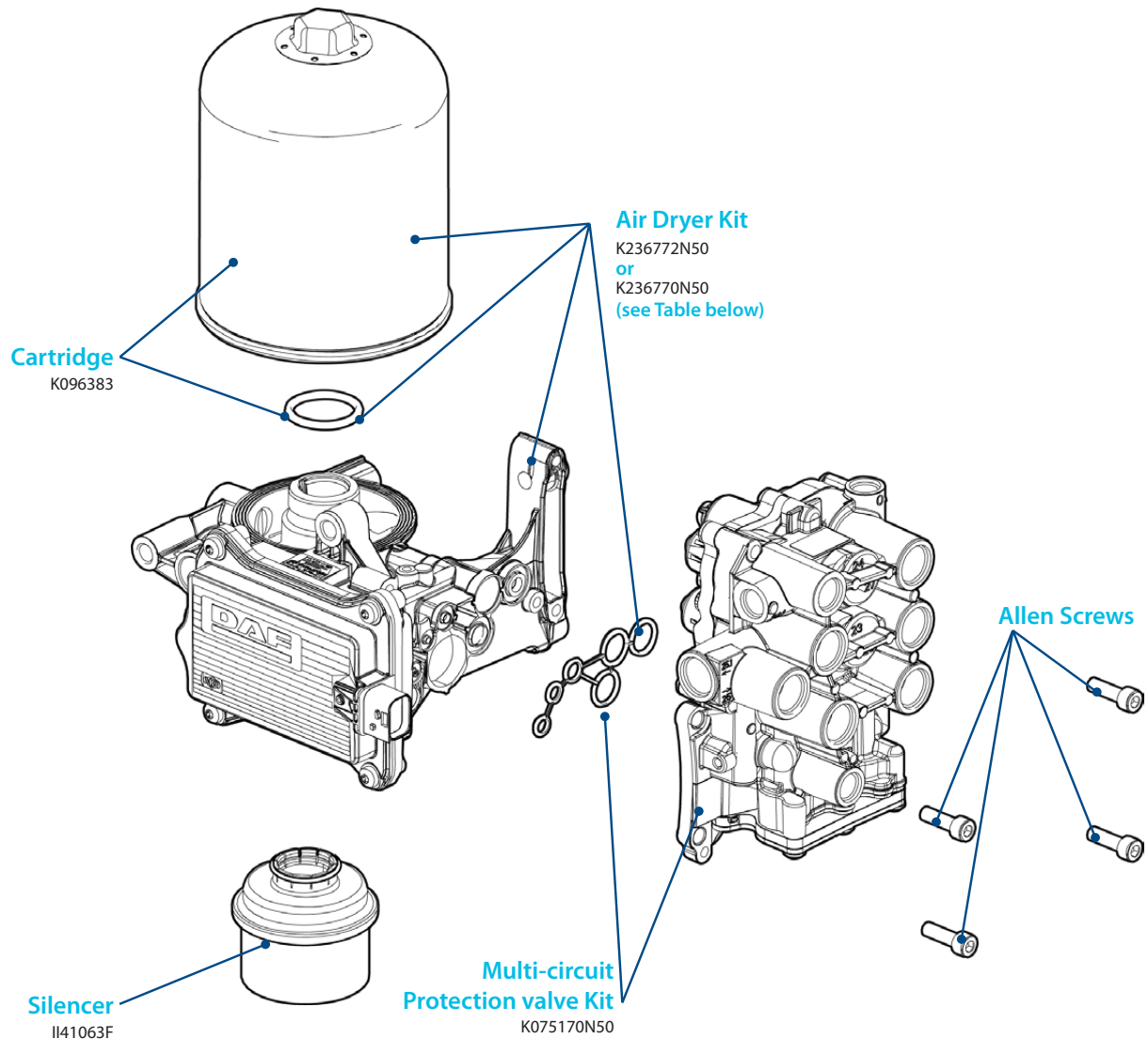

EAC2.1 OE Partnumbers		Air Dryers for EAC2.1		MCPV for EAC2.1	
KB OE PN	Manufacturer PN	KB IAM PN	Manufacturer PN	KB IAM PN	Manufacturer PN
K079158N02	1973210	K236772N50	1973216	K075170N50	1913300
K079159N02	1973211				
K079160N02	1973212				
K079161N02	1973213				
K127961N02	2027747	K236770N50	2110114		
K127962N02	2027748				
K127963N02	2027749				
K127964N02	2027750				

Note: The "Vehicle Manufacturer PN." should only be used as a reference for the identification of the relevant IAM part numbers. The information is supplied without liability.

- Compatible with NEO and KTS diagnostic platforms

€ - A core deposit will be applied

Spare kits for EAC2.1

IAM PN	Product	OE PN	Manufacturer PN
K096383	OSC Cartridge M39x1.5RH hex	K092250N52	19215363
II41063F	Silencer	II41063FK52	1943159

Related documents

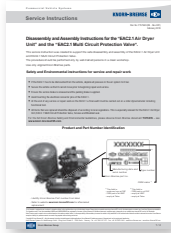
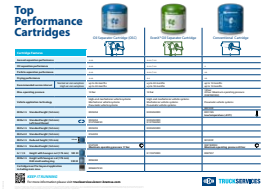
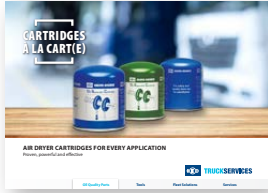
Document	Description	
Service Manual Y157643	Service Manual for EAC2.1	
Cartridge Poster Y198501	Overview of Cartridges and applications	
Cartridge Brochure Y255975	Advantages of Knorr-Bremse Cartridges	

KEEP IT RUNNING

Up-to-date information on our products can be found on our website truckservices.knorr-bremse.com



Knorr-Bremse Systems for Commercial Vehicles
Moosacher Strasse 80 | 80809 Munich | Germany
Tel: +49 89 3547-0
Fax: +49 89 3547-2767
truckservices.knorr-bremse.com

Note
All information is subject to change. A printed version of this document may therefore not correspond to the latest revision. To obtain the latest version, please visit our website truckservices.knorr-bremse.com or contact a Knorr-Bremse representative in your area.

If service work is carried out on a vehicle based on information provided herein, it is the responsibility of the workshop to ensure the vehicle is fully tested and in full functional order before the vehicle is returned into service. Knorr-Bremse accepts no liability for problems caused as a result of appropriate tests not being carried out.

Copyright © Knorr-Bremse AG
All rights reserved, including industrial property rights applications. Knorr-Bremse AG retains any power of disposal, such as for copying and transferring.

Disclaimer
The information contained herein is intended for the exclusive use of trained persons within the commercial vehicle industry, and must not be passed on to any third party. All recommendations regarding products and their servicing or usage are with reference to Knorr-Bremse products and should not be considered applicable to products from other manufacturers. This information does not purport to be all-inclusive and no responsibility is assumed as a result of its use. We cannot accept any liability nor offer any guarantee regarding data accuracy, completeness or timeliness. The information does not represent any guarantee or ensured characteristics of the Products or Systems described. No liability can be accepted based on the information, its use, recommendations or advice provided. In no event may we be held liable for any damage or loss except in the case of wilful intent or gross negligence on our part, or if any mandatory legal provisions apply. This disclaimer is an English translation of a German text, which should be referred to for all legal purposes. Any legal disputes arising from the use of this information shall be subject to German law.