



# Installation Instructions

## FIELD MAINTENANCE KIT FOR SR-1 SPRING BRAKE VALVE

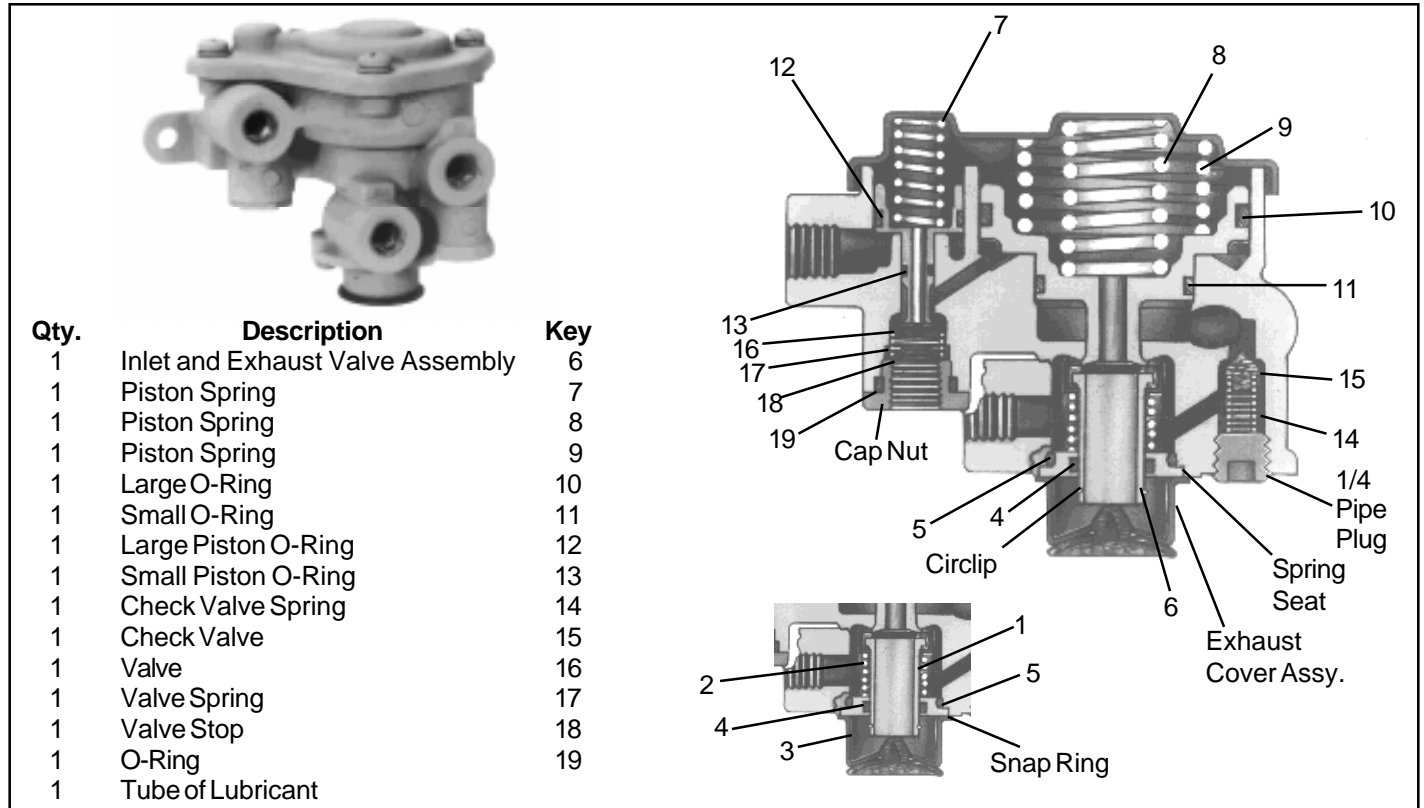

Figure 1 This kit consists of the parts listed above.

**IMPORTANT! PLEASE READ AND FOLLOW THESE INSTRUCTIONS TO AVOID PERSONAL INJURY OR DEATH:**

When working on or around a vehicle, the following general precautions should be observed at all times.

1. Park the vehicle on a level surface, apply the parking brakes, and always block the wheels.
2. Stop the engine when working around the vehicle.
3. If the vehicle is equipped with air brakes, make certain to drain the air pressure from all reservoirs before beginning ANY work on the vehicle.
4. Following the vehicle manufacturer's recommended procedures, deactivate the electrical system in manner that removes all electrical power from the vehicle.
5. When working in the engine compartment the engine should be shut off. Where circumstances require that the engine be in operation, **EXTREME CAUTION** should be used to prevent personal injury resulting from contact with moving, rotating, leaking, heated, or electrically charged components.

6. Never connect or disconnect a hose or line containing pressure; it may whip. Never remove a component or plug unless you are certain all system pressure has been depleted.
7. Never exceed recommended pressures and always wear safety glasses.
8. Do not attempt to install, remove, disassemble or assemble a component until you have read and thoroughly understand the recommended procedures. Use only the proper tools and observe all precautions pertaining to use of those tools.
9. Use only genuine Bendix replacement parts, components, and kits. Replacement hardware, tubing, hose, fittings, etc. should be of equivalent size, type, and strength as original equipment and be designed specifically for such applications and systems.
10. Components with stripped threads or damaged parts should be replaced rather than repaired. Repairs requiring machining or welding should not be attempted unless specifically approved and stated by the vehicle or component manufacturer.
11. Prior to returning the vehicle to service, make certain all components and systems are restored to their proper operating condition.

## REMOVAL

1. Prior to removing the SR-1, apply the parking brakes and drain all the vehicle reservoirs.
2. Identify all air lines before disconnecting.
3. Remove the two mounting bolts from the SR-1 and remove the valve.

## DISASSEMBLY OF THE SR-1 VALVE

Note: The SR-1 valve comes with two different styles of exhaust covers. The exhaust cover is attached to the valve body by one of two methods, two 10-24 screws or a snap ring. These parts are not interchangeable and if being replaced must be replaced with like part.

1. Using a #2 Phillips screwdriver or snap ring pliers remove the two 10-24 screws or the snap ring that retains the exhaust cover assembly to the valve body. Retain these parts as they will be required for the reassembly process. Remove the inlet/exhaust valve assembly(6), or component parts(1 thru 5) (Inset view). **CAUTION:** Do not disassemble the snap in spring seat attached to the exhaust cover.
2. Using the 7/8" open-end wrench, remove the hex cap nut and discard items (16), (17), (18) and (19).
3. Remove the 1/4" recessed hex pipe plug and discard items (14) and (15).
4. Place valve horizontally in a vise and lightly compress the cover to the body. Using the #3 Phillips screwdriver or a 1/2" socket (some have Phillips head screws while others have cap screws). Remove the cover, keep (7), (8), (9) for size match up with the replacement parts and then discard items (7), (8), (9), (10), (11), (12), and (13).

Prior to assembly of new parts in valve, clean all internal parts and passages with a suitable solvent equivalent to mineral spirits.

Grease all o-rings, bores, pistons and internal parts with lubricant supplied in kit.

## REASSEMBLY OF VALVE

1. Install o-rings, items (12) and (13) in proper grooves of small piston and install piston in bore of body.
2. Install o-rings, items (10) and (11) in proper grooves of larger piston and install piston in bore of body.

Note: When repairing valves, compare the springs removed with those provided in the kit and only use the appropriate size and quantity that were present when valve was disassembled.

3. Insert springs (7), (8) and (9) in their proper position using the cover to hold them in place. Using the vise, lightly compress the cover to the body, making sure all springs are properly aligned in their bores. Install the four #1/4"-20 screws and torque to 50-80 inch pounds.

4. Twist the spring(14) over the neck of the check valve(15) and place assembly into the body. Reinstall the 1/4" pipe plug and torque from 130 to 170 inch pounds.
5. Drop wafer valve(16) in bore, making sure it is laying flat. Insert spring(17) on the four ears of the wafer valve. Place the valve stop(18) on top of spring. Position o-ring(19) on cap nut, install and tighten nut to 100-250 inch pounds torque.

Note: For valves that incorporate screws to retrain the exhaust cover to the body follow Step 6. For snap ring style proceed to Step 7 and 8.

6. Drop inlet and exhaust valve cartridge(6) in place. Position exhaust cover assembly and tighten with the two #10-24 screws to 20-30 inch pounds torque. Proceed to Step 9.
7. Disassemble the inlet/exhaust valve cartridge(6) provided in this kit by pressing down on the spring seat next to the cir-clip, with a small screw driver remove the cir-clip and spring seat. Remove the two o-rings(4 & 5) from the spring seat. Discard the cir-clip and the spring seat.
8. (Refer to inset view) Place the inlet/exhaust valve body, valve retainer, and spring into the valve housing. Place the two o-rings(4 & 5) (removed in Step 7) onto the exhaust cover assembly(3). Place the exhaust cover subassembly onto the barrel of the inlet/exhaust valve body (taking care that the o-rings remain in their proper position) and compress the spring until the snap ring can be installed in its groove. Make sure the snap ring is fully seated.
9. Perform "Operating and Leakage Checks."

## INSTALLATION

1. Using the two mounting bolts, install the SR-1 on the vehicle.
2. Using the identification made in Step 2 of the "Removal" procedure, install the air lines.

## OPERATING CHECKS

Block vehicle and hold by means other than vehicle brakes. Charge air brake system to governor cut-out pressure.

1. Place parking control valve in the "park" position. Observe that the spring brake actuators apply promptly. In the delivery port of the valve, install a test gauge known to be accurate. Place the parking control valve in the "release" position. Observe that the spring brake actuators release fully.
2. With the parking control valve in the "release" position, note the gauge pressure reading. (Check the vehicle manual for the correct spring brake actuator hold-off pressure.) If the pressure reading is incorrect, the valve must be repaired or replaced.
3. Place the parking control valve in the "park" position; the

gauge reading should drop to zero promptly. A slow release of pressure may indicate faulty operation of the single check valve(15) (within the Modulating Valve).

4. Place the parking control valve in the "release" position. Locate the number one service reservoir and drain it completely.

Apply the foot brake valve several times and note that the pressure reading on the gauge decreases each time the foot brake valve is applied. After several applications, pressure on the gauge will drop to the point where release of the spring brake actuators will no longer occur.

#### **LEAKAGE CHECK**

With the air system fully charged and the parking control valve in the "release" position, coat the exhaust port and around the valve cover with a soap solution. Slight leakage is permitted.

If the SR-1 Spring Brake Valve does not function as described above, or leakage is excessive, it is recommended that it be returned to the nearest Bendix authorized distributor for a new or remanufactured valve.

