

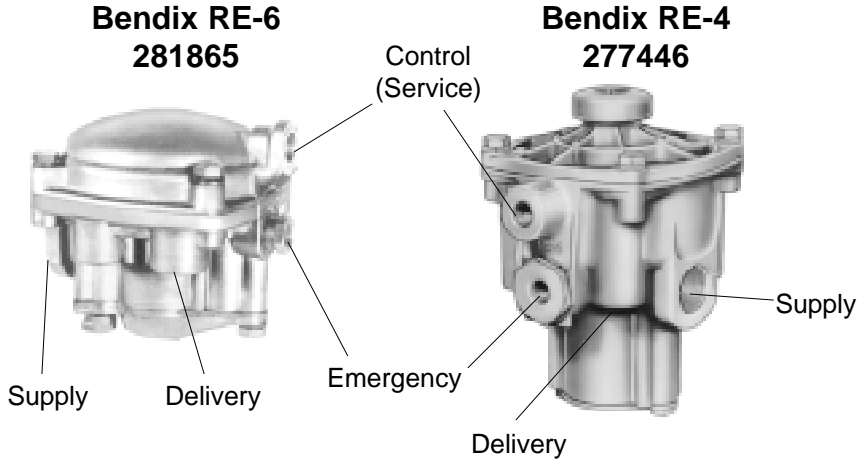

# Installation Instructions

## RE-4 & RE-6 RELAY EMERGENCY VALVES



To  
These Bendix Valves

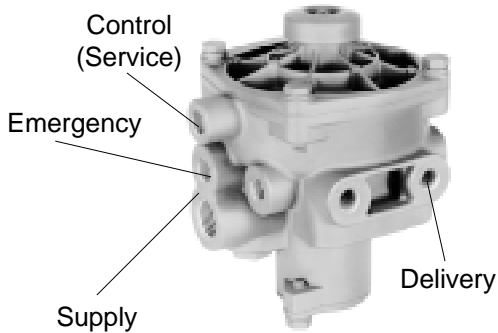

**Bendix RE-4 229434 (Obsolete)**

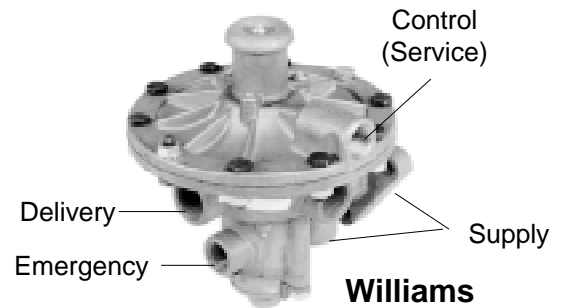

**Williams**

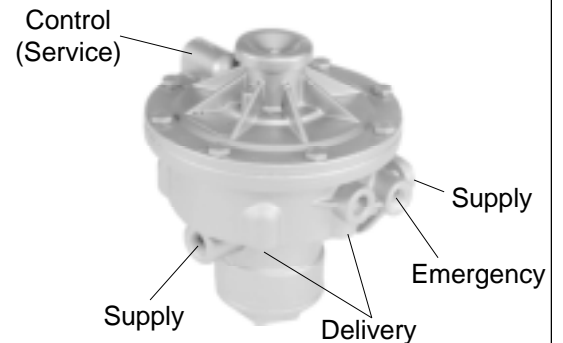

**Midland**

From  
These Valves

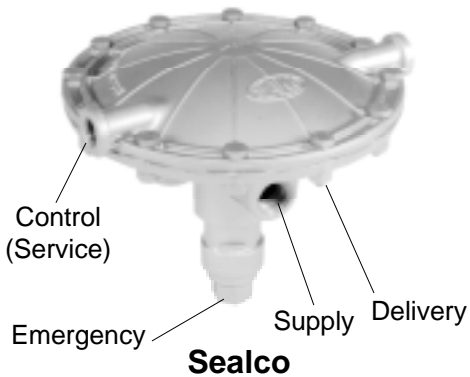

**Sealco**

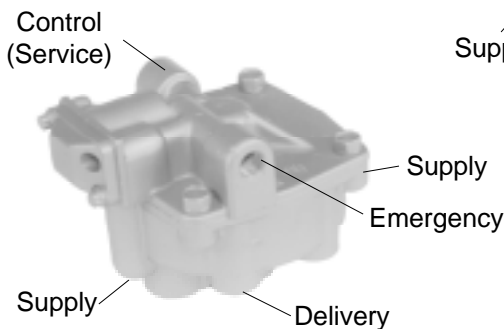

**Wagner**

**IMPORTANT! PLEASE READ AND FOLLOW THESE INSTRUCTIONS TO AVOID PERSONAL INJURY OR DEATH:**

When working on or around a vehicle, the following general precautions should be observed at all times.

1. Park the vehicle on a level surface, apply the parking brakes, and always block the wheels.
2. Stop the engine when working around the vehicle.
3. If the vehicle is equipped with air brakes, make certain to drain the air pressure from all reservoirs before beginning ANY work on the vehicle.
4. Following the vehicle manufacturer's recommended procedures, deactivate the electrical system in manner that removes all electrical power from the vehicle.
5. When working in the engine compartment the engine should be shut off. Where circumstances require that the engine be in operation, **EXTREME CAUTION** should be used to prevent personal injury resulting from contact with moving, rotating, leaking, heated, or electrically charged components.
6. Never connect or disconnect a hose or line containing pressure; it may whip. Never remove a component or plug unless you are certain all system pressure has been depleted.
7. Never exceed recommended pressures and always wear safety glasses.
8. Do not attempt to install, remove, disassemble or assemble a component until you have read and thoroughly understand the recommended procedures. Use only the proper tools and observe all precautions pertaining to use of those tools.
9. Use only genuine Bendix replacement parts, components, and kits. Replacement hardware, tubing, hose, fittings, etc. should be of equivalent size, type, and strength as original equipment and be designed specifically for such applications and systems.
10. Components with stripped threads or damaged parts should be replaced rather than repaired. Repairs requiring machining or welding should not be attempted unless specifically approved and stated by the vehicle or component manufacturer.
11. Prior to returning the vehicle to service, make certain all components and systems are restored to their proper operating condition.

**VALVE INTERCHANGEABILITY**

The RE-4 or RE-6 valves can be used to replace a variety of competitive valves. Refer to the illustrations of the valves, the air connection comparison chart and the schematics presented.

Both RE-4 styles and the RE-6 are interchangeable in fit and function. Where needed, reducer bushings have been included to assure port thread sizes are standard from one style to the other. The RE-4 can be frame-rail mounted or reservoir flange-mounted (for a special reservoir in use - see page 4).

Changeover Kit 5000788

Bendix RE-4 pc. no. 229434 is obsolete. For a direct changeover from 229434 to 277446, kit pc. no. 5000788 can be used. This kit includes reducer bushings, a special reservoir adapter (if needed), and two tee fittings, for tri-axle trailer applications that require additional delivery lines. (See schematic on page 4.)

**VALVE REMOVAL**

1. Identify and mark or label all air lines and their respective connections on the valve to facilitate ease of installation.
2. Disconnect the air lines.
3. Remove all fittings from the valve assembly.
4. Remove the valve assembly from the vehicle.
5. Before proceeding to Valve Installation, inspect all air lines connected to the valve for signs of deterioration and replace as needed.

**VALVE INSTALLATION**

1. Install all air line fittings and plugs making certain thread sealing material does not enter the valve.
2. Install the assembled valve on the vehicle.
3. Re-connect all air lines to the valve using the identification made during VALVE REMOVAL step 1.
4. After installing the valve, test all air fittings for excessive leakage and tighten as needed.

Air Connection	Bendix 229434	Bendix 277446	Bendix 281865	Midland	Sealco	Wagner	Williams
Horizontal Delivery Ports (No. & Size)	4 - 1/4" NPT	None	None	2 - 1/4" NPT	None	4 - 1/4" NPT	3 - 1/2" NPT
Vertical Delivery Ports (No. & Size)	2 - 1/4" NPT	4 - 1/4" NPT or (2 - 1/4" + 2 - 3/8" NPT)	4 - 1/4" NPT or (2 - 1/4" + 2 - 3/8" NPT)	4 - 1/4" NPT	4 - 1/4" NPT	None	4 - 1/4" NPT
Supply Ports (No. & Size)	2 - 1/2" NPT 1 - 3/4" NPT	2 - 3/4" P.T.	1 - 3/8" NPT 1 - 3/4" NPT	1 - 3/8" NPT 1 - 3/4" NPT	1 - 1/2" NPT	2 - 3/8" NPT	2 - 1/2" NPT
Service or Control Ports (No. & Size)	2 - 1/4" NPT	1 - 1/4" NPT	1 - 1/4" NPT	1 - 1/4" NPT	2 - 1/4" NPT	1 - 1/4" NPT	1 - 1/4" NPT
Emergency Ports (No. & Size)	2 - 1/4" NPT	1 - 1/4" NPT	1 - 1/4" NPT	1 - 1/4" NPT	1 - 3/8" NPT	1 - 3/8" NPT	1 - 1/4" NPT

**Typical Converter Dolly System  
(Prior to November 1992)**

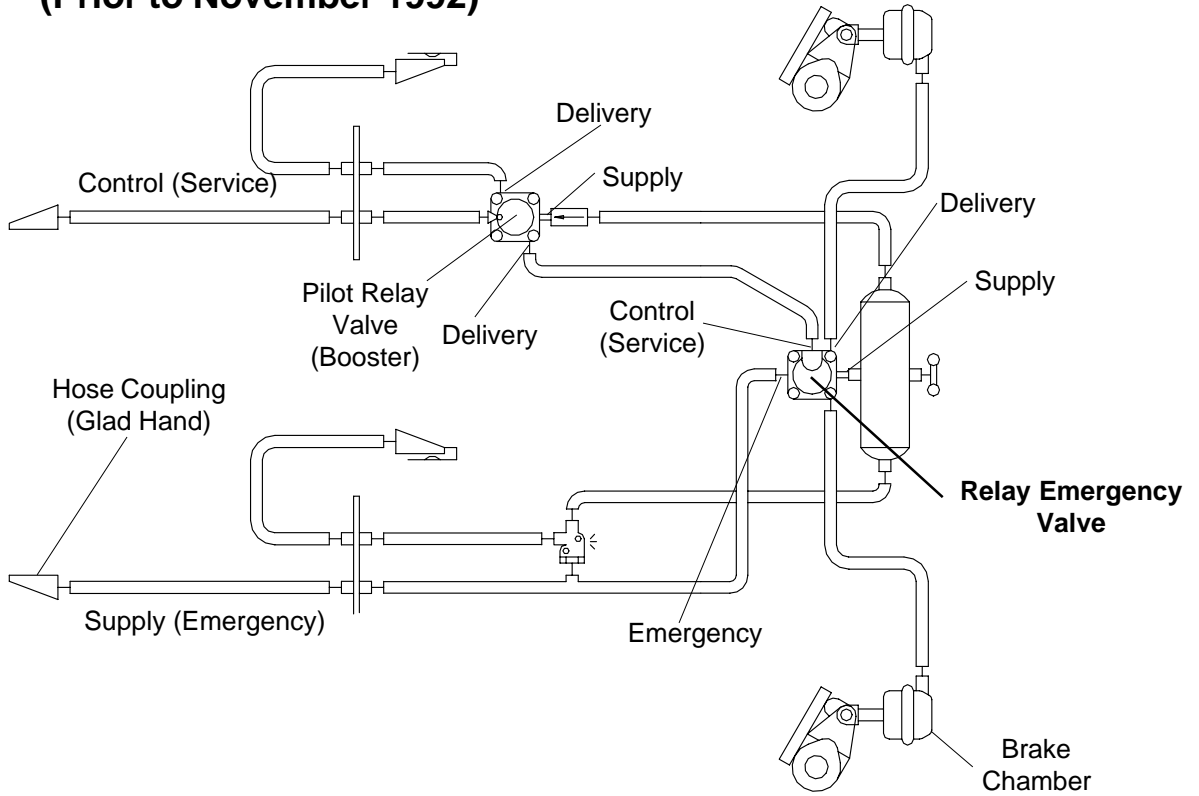

**Typical Single Axle Semi-Trailer System  
(Prior to January 1975)**

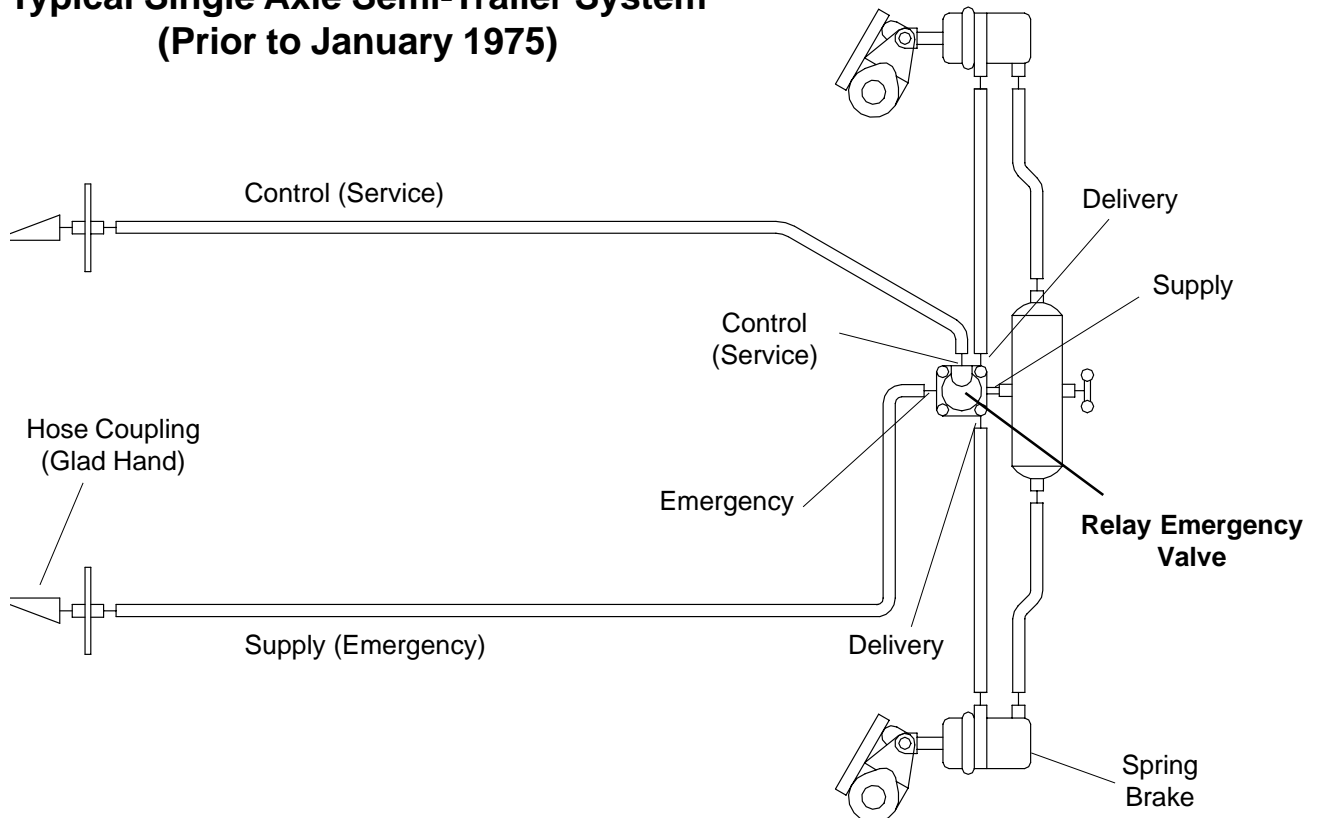

# Typical Tri-Axle Semi-Trailer System (Prior to January 1975)

