



# Installation Instructions

KIT Pc. No.  
109368

## ATR-1 & AR-1 MAINTENANCE KIT

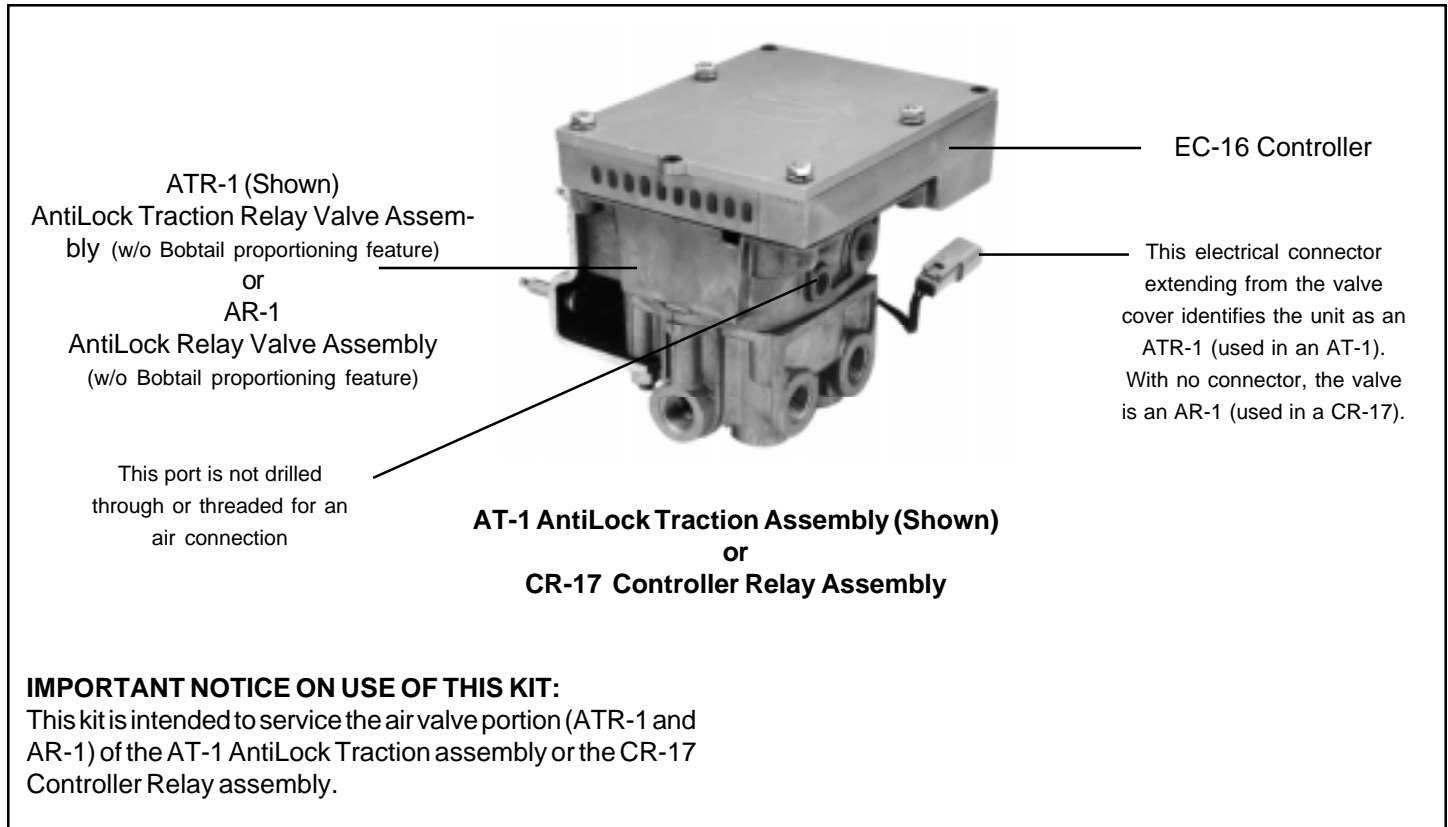

Figure 1 AT-1 & CR-17 Identification

**IMPORTANT! PLEASE READ AND FOLLOW THESE INSTRUCTIONS TO AVOID PERSONAL INJURY OR DEATH:**

When working on or around a vehicle, the following general precautions should be observed at all times.

1. Park the vehicle on a level surface, apply the parking brakes, and always block the wheels.
2. Stop the engine when working around the vehicle.
3. If the vehicle is equipped with air brakes, make certain to drain the air pressure from all reservoirs before beginning ANY work on the vehicle.
4. Following the vehicle manufacturer's recommended procedures, deactivate the electrical system in manner that removes all electrical power from the vehicle.
5. When working in the engine compartment the engine should be shut off. Where circumstances require that the engine be in operation, **EXTREME CAUTION** should be used to prevent personal injury resulting from contact with moving, rotating, leaking, heated, or electrically charged components.
6. Never connect or disconnect a hose or line containing pressure; it may whip. Never remove a component or plug unless you are certain all system pressure has been depleted.
7. Never exceed recommended pressures and always wear safety glasses.
8. Do not attempt to install, remove, disassemble or assemble a component until you have read and thoroughly understand the recommended procedures. Use only the proper tools and observe all precautions pertaining to use of those tools.
9. Use only genuine Bendix replacement parts, components, and kits. Replacement hardware, tubing, hose, fittings, etc. should be of equivalent size, type, and strength as original equipment and be designed specifically for such applications and systems.
10. Components with stripped threads or damaged parts should be replaced rather than repaired. Repairs requiring machining or welding should not be attempted unless specifically approved and stated by the vehicle or component manufacturer.
11. Prior to returning the vehicle to service, make certain all components and systems are restored to their proper operating condition.

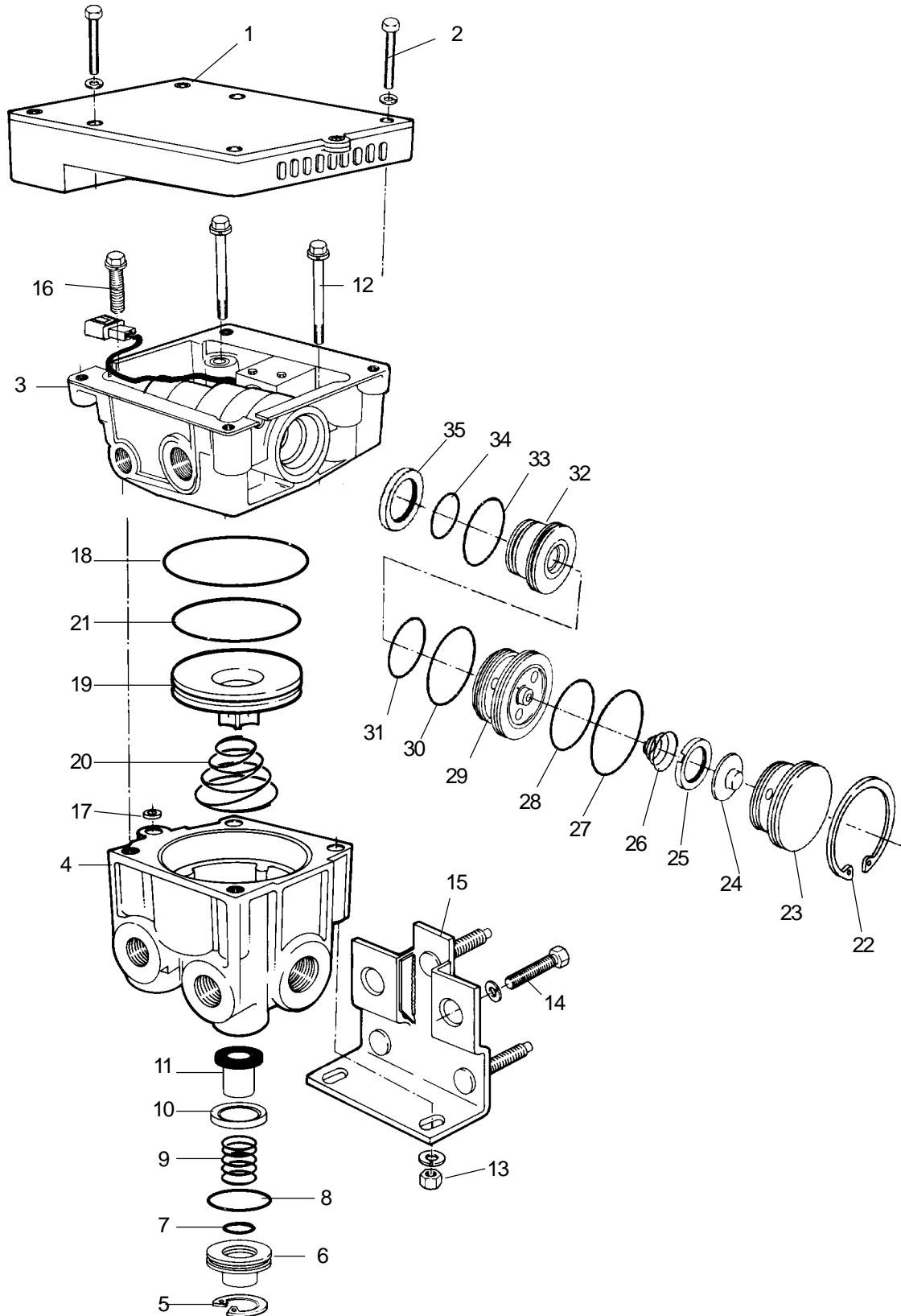
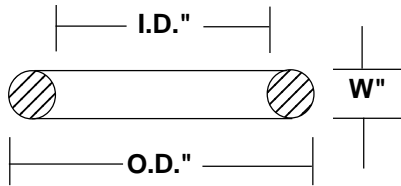

Figure 2 AntiLock Assembly Exploded View

This kit contains the following parts that are keyed to figure 2. Note the O-Ring dimensions given to help in identification.



### O-RING IDENTIFICATION

Key	Description	Qty.	O-Ring Identification		
			I.D.	O.D.	W
5	Retaining Ring	1	--	--	--
6	Exhaust Cover	1	--	--	--
7	O-Ring	1	0.862	1.068	0.103
8	O-Ring	1	1.424	1.63	0.103
9	Valve Spring	1	--	--	--
10	Valve Retainer	1	--	--	--
11	Inlet/Exhaust Valve	1	--	--	--
17	Sealing Ring	1	--	--	--
18	O-Ring	1	3.487	3.693	0.103
21	O-Ring	1	3.234	3.512	0.139
22	Retaining Ring	1	--	--	--
24	Check Valve	1	--	--	--
26	Spring	1	--	--	--
27	O-Ring	1	1.362	1.568	0.103
28	O-Ring	1	1.114	1.254	0.07
30	O-Ring	1	1.356	1.496	0.07
31	O-Ring	1	1.176	1.316	0.07
33	O-Ring	1	1.112	1.318	0.103
34	O-Ring	1	0.737	0.943	0.103
--	Grease	1	--	--	--

Figure 3 Kit Contents and O-Ring Identification

### VEHICLE PREPARATION

1. Park the vehicle on a level surface and block the wheels and/or hold the vehicle by means other than the air brakes.
2. Drain the air pressure from all vehicle reservoirs.

### REMOVAL

1. Identify and mark or label all electrical wiring harnesses and air lines and their respective connections on the assembly to facilitate ease of installation.
2. Disconnect the air lines and wire harnesses.
3. Remove the controller and valve assembly from the vehicle.

### PREPARATION FOR DISASSEMBLY

1. Remove all air fittings and plugs from the valve.
2. Mark the relationship of the valve cover(3) to the body(4) and, if the valve is equipped with a mounting bracket(14), mark the relationship of the bracket to the cover and body(4).
3. Mark the relationship of the electronic controller(1) to the cover(3).

### DISASSEMBLY

**CAUTION:** The valve may be lightly clamped in a bench vise during disassembly, however, over clamping will result in damage to the valve and result in leakage and/or malfunction. If a vise is to be used, position the valve so that the jaws bear on the supply ports on opposing sides of the valve body.

1. While holding the exhaust cover(6), remove and discard the retaining ring(5) that secures it to the body(4).
2. Remove and discard the exhaust cover(6) along with both o-rings(7 & 8).
3. Remove and discard the valve spring(9), valve retainer(10), and the valve assembly(11) from the body(4).
4. Referring to figure 2, remove and retain the four cap screws(2) that secure the electronic controller(1) to the cover(3), then separate the controller(2), from the cover(3) and retain the controller(2).
5. Remove and retain the two long cap screws(12) and nuts(13) that secure the cover(3) to the body(4).
6. Remove and retain the two cap screws and lock washers(14) that secure the bracket(15) to the cover(3), then remove and retain the bracket.
7. Remove and retain the two short cap screws(16) that secure the cover(3) to the body(4).
8. Separate the cover(3) from the body(4), then remove and discard the sealing ring(17) and o-ring(18).
9. Remove and retain the relay piston(19) and relay piston spring(20) from the body(4). NOTE: The relay piston spring, item 20 is not used in all valves.
10. Remove and discard the o-ring(21) from the relay piston(19).
11. Remove and discard the retaining ring(22). Then remove check valve seat(23), with o-rings(27 & 28). Remove and discard o-rings(27 & 28) from the check valve seat.
12. Remove the check valve(24), guide(25), and spring(26) and discard the check valve and spring. Retain the valve guide(25).
13. Remove the inlet seat(29) with o-rings(30 & 31), then remove and discard o-rings(30 & 31) from the inlet seat(29).
14. Using a "fish hook" shaped wire carefully extract the blend back piston(32) from the valve cover(3). Retain the piston(32) but remove and discard both o-rings(33 & 34).
15. Remove and retain the spacer ring(35).

## CLEANING & INSPECTION

1. Using mineral spirits or an equivalent solvent, clean and thoroughly dry all metal parts. Do not damage bores with metal tools.
2. Wash all **retained**, non-metallic components in a soap and water solution making certain to rinse and dry thoroughly.
3. Inspect the interior and exterior of all metal parts that will be reused for severe corrosion, pitting and cracks. Superficial corrosion and/or pitting on the exterior portion of the body(4) and cover(3) is acceptable. Replace the entire valve if the interior of the body or cover exhibit signs of severe corrosion or pitting.
4. Inspect each nonmetallic component for cracks, wear or distortion. Replace the entire valve if these conditions are found.
5. Inspect the bores of both the body(4) and cover(3) for deep scuffing or gouges. Replace the entire valve if either are found.
6. Make certain the air channel running between the top surface of the body(4) and its supply port is clear and free of obstruction.
7. Make certain all air channels and exhaust passages in the valve cover(3) are clear and free of obstruction.
8. Inspect the pipe threads in the body(4) and valve cover(3). Make certain they are clean and free of thread sealant.
9. Inspect the relay piston spring(20) for signs of corrosion, pitting and cracks. Replace as necessary.
10. Inspect all air line fittings for corrosion and replace as necessary. Make certain to remove all old thread sealant before reuse.

## ASSEMBLY

1. Prior to assembly, lubricate all o-rings (See Figure 3), seals, and pistons, as well as body and cover bores, using the lubricant provided with this kit. Use all of the lubricant and spread it evenly on the rubbing surfaces.
2. Install the spacer ring(35) on the blend back piston(32).
3. Install both the large and small diameter o-rings(33 & 34) on the blend back piston(32).
4. Carefully insert the assembled blend back piston(32) into the bore in the cover(3). Do not cut or pinch the o-rings.
5. Install the small and large diameter o-rings(31 & 30) on the inlet seat(29) then insert the inlet seat into the bore in the cover(3).
6. Install the small and large diameter o-rings(28 & 27) on the check valve seat(23).
7. Install the spring(26) on the inlet seat(29) so that the small diameter fits over and around the air passage through the center of the inlet seat.
8. Install the check valve(24) and valve guide(25) in the check valve seat(23). Note; The check valve must be installed so that the "top hat" portion fits into the valve seat(23). Install the valve guide(25) so that its flange contains (surrounds) the coils of the large end of the spring(26), when the valve seat(23) is installed in the

- cover(3). Use a small amount of the grease provided in this kit to hold these parts in the valve seat(23).
9. Install the assembled valve seat(23) with the check valve and valve guide(24 & 25) into the cover(3) bore and while holding it in place install the retaining ring(22). Make certain the retaining ring is fully seated in its groove.
10. Install the valve retainer(10) on the inlet and exhaust valve(11) so that the flange of the retainer(10) surrounds the rubber portion of the valve. Install the inlet and exhaust valve in the body(4).
11. Install the inlet and exhaust valve return spring(9) in the body(4).
12. Install the large and small diameter o-rings(8 & 7) in the exhaust cover(6), then install the exhaust cover in the body(4) taking care not to damage the o-rings. Hold the exhaust cover in place.
13. While depressing the exhaust cover(6), install the retaining ring(5) in the body(4). Make certain the retainer(5) is fully seated in its groove in the body.
14. If the valve (ATR-1 or AR-1) was equipped with a relay piston return spring(20), install the spring in the body, large diameter first.
15. Using lubricant to hold them in place, install the large and small sealing rings(18 & 17) on the cover(3).
16. Install the o-ring(21) on the relay piston(19), then install the piston in the body(4).
17. Note the relationship marks made prior to disassembly, then install the cover(3) on the body(4). Secure the cover(3) on the body(4) using the two, short cap screws(16). Again, noting the relationship marks, secure the bracket(15) on the cover(3) and body(4) and using the two long cap screws(12) and two nuts and washers(13). Torque the four cap screws to 120 to 150 lb. in.
18. Install the two cap screws(14) that secure the bracket(15) to the cover(3) and torque to **180 - 220** pound inches.
19. Noting the relationship marks made during disassembly, secure the controller(1) to the cover(3) using the four cap screws(2). Torque the four cap screws to **80-150** pound inches.
20. Install all air line fittings and plugs making certain thread sealing material does not enter the valve.

## INSTALLATION

1. Install the assembled unit on the vehicle.
2. Reconnect all air lines and wire harnesses to the unit using the identification made during REMOVAL step 1.
3. After installing the unit, perform the "OPERATION & LEAKAGE TESTS" for the air valve before placing the vehicle in service.

## **OPERATION & LEAKAGE TESTS**

### **General**

A change in vehicle braking characteristics or a low pressure warning may indicate a malfunction in one or the other brake circuit, and although the vehicle air brake system may continue to function, the vehicle should not be operated until the necessary repairs have been made and both braking circuits, including the pneumatic and mechanical devices are operating normally. Always check the vehicle brake system for proper operation after performing brake work and before returning the vehicle to service.

### **Operation Check**

1. Apply and release the brakes several times and check for prompt application and release at each wheel.
  - A. If a prompt reaction is noted at some, but not all wheels, test the AntiLock modulator (M-21 or M-22) between the ATR-1 and the brake chamber for proper operation. If a "sluggish" response is noted at all wheels, inspect for a kinked or obstructed air line leading to or from the ATR-1.
  - B. If a complete release of the brakes is noted at some, but not all wheels, test the AntiLock modulator (M-21 or M-22) between the ATR-1 and the brake chamber for proper operation. If an incomplete release is noted at all wheels, inspect for a kinked or obstructed air line leading to or from the ATR-1.

2. The AR-1 or ATR-1 differential pressure can be checked by applying 10 psi to the service port and noting the pressure registered at the delivery port. Subtract delivery port pressure from the 10 psi service pressure to obtain the differential. Compare the measured differential with the pressure specified for the AR-1 or ATR-1 part number (see the I.D. washer for the differential).

*NOTE: For AR-1 or ATR-1 valves not incorporating a relay piston return spring(20) the measured differential should be approximately 4 psi. When a spring is in use, the differential will be higher.*

### **Leakage Check**

1. Build the air system pressure to governor cutout. With the dash mounted trailer supply valve activated for tractor/trailer operation, apply a soap solution to all three exhaust ports (two in cover and one in body). The leakage noted should not exceed a one inch bubble in less than three seconds at any exhaust port.
2. Make and hold a full brake application and apply a soap solution to all three exhaust ports and around the cover where it joins the body. The leakage noted should not exceed a one inch bubble in less than three seconds at any exhaust port.
3. If the ATR-1 or AR-1 fails to function as described, or leakage is excessive, it should be replaced with a new or genuine Bendix remanufactured unit, available at any authorized parts outlet.