



# Installation Instructions

## Bendix® EC-15™ to EC-30™ Controller Service Replacement Kit

### KIT CONTENTS

Item No.	Description	Qty.
1.	Adapter Harness	1
2.	Adapter Plate	1
3.	Replacement ECU	1
(not shown)	Service Data Sheet	1
(not shown)	ECU Mounting Bolts	4



Above: Bendix® EC-15™ Controller,  
Right: EC-30™ Controller

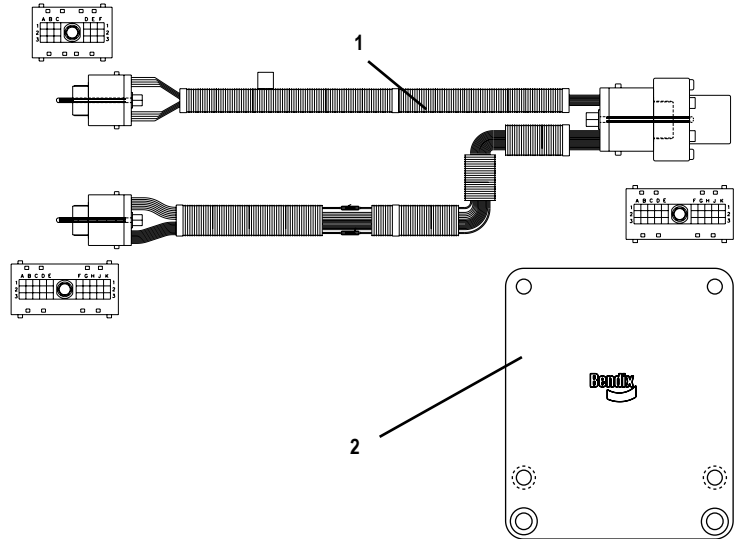

FIGURE 1 - KIT CONTENTS

This kit is intended to provide the necessary components to replace the Bendix® EC-15™ ECU (electronic control unit) with the Bendix® EC-30™ ECU controller.

Note: Typically, the Adapter Plate is only used where the EC-30™ controller is mounted on a relay valve.

**Read and follow all standard safety guidelines, including those found in the General Maintenance Precautions section of this document.**

### REMOVING CONTROLLER ASSEMBLY

#### General Information

1. Locate the EC-15™ ECU on the vehicle.
2. Remove any contamination from the exterior of the controller, relay valve, assembly and electrical connectors.
3. With vehicle ignition OFF, disconnect the electrical connectors from the controller. Keep contamination away from the electrical connections.
4. Note the mounting location of controller. If the EC-15™ controller is mounted on a relay valve, you will need to install an adapter plate for the replacement ECU.
5. Inspect the bolts that secure the controller to the frame rail or valve body for the presence of corrosion and its severity. Where necessary, use penetrating oil and very lightly tap the head of the cap screw to help the oil free up any corroded threads. (NOTE: Use a high-quality silicone fluid or silicone release spray). It may be necessary to wait several minutes and repeat the process before attempting to remove the screws. Bendix does not recommend the use of an impact wrench when removing the cap screws.

6. Remove and discard the four mounting bolts.
  7. Remove the EC-15™ controller from the valve or frame rail.
- NOTE: Be sure when determining where to mount the EC-30™ controller that you take into account that the new adapter harness will need to be routed to connect to both the existing vehicle harness and the EC-30™ Controller ABS ECU.

### INSTALLING EC-30™ CONTROLLER ECU

Note: Use new mounting bolts for the installation.

When deciding where to mount the EC-30™ Controller, please keep in mind the following:

- a. The EC-30™ Controller must not be subjected to direct tire spray.
- b. The ECU must be mounted in a location where the minimum (-40°C) and maximum (+85°C) operating temperatures will not be exceeded.

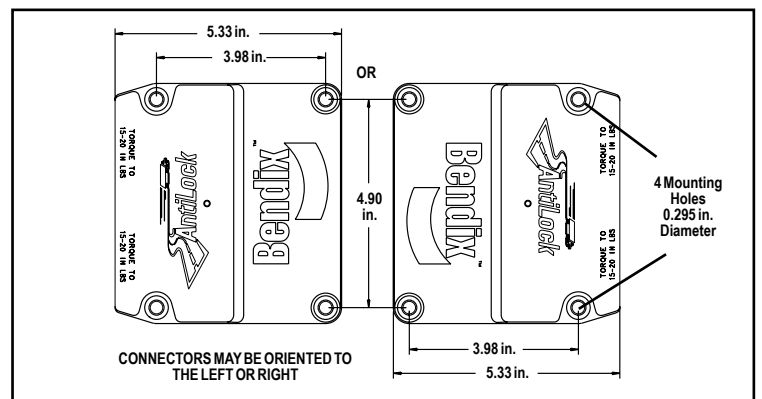

FIGURE 2 - FRAME MOUNT RECOMMENDED SIDWAYS ORIENTATION

- c. Determine if the EC-30™ controller will be mounted on a relay valve or on the frame. In either case, be sure that the harness will reach both the old harness and the ECU without strain.
- d. If the EC-30™ controller is mounted on the frame, Bendix strongly recommends that the orientation is parallel to the frame (see Figure 2). Mark the mounting hole locations, and drill the 4 mounting holes (0.295 in. diameter).
- e. If the EC-30™ controller is to be mounted on a relay valve, the adapter plate included in this kit will be required. Mount the EC-30™ controller using Grade 5 stainless steel bolts; the maximum torque permitted is 98 in-lbs.

ECU Installation	yes	no*
Is the ECU mounted where it will not be subjected to direct wheel spray or temperatures of lower than -40° C or more than +85° C?		
Is the ECU mounted in a location where moisture can drain away from it?		
Is the ECU (frame) mounted in a sideways manner (see Figure 2)?		
Are the ECU mounting bolts properly torqued (maximum permitted is 98 in-lbs.)?		

\*If any of the questions were answered with a “No”, the Antilock system should be review by a qualified individual. For technical assistance, call the Bendix Technical Assistance Team at (800)-247-2725.

## INSTALLING THE ADAPTER HARNESS

1. Connect the 30-pin vehicle harness connector into the 30-pin connector of the adapter harness.
2. Be sure that the adapter harness has adequate strain relief when installed so that it can be routed freely and is not pulled tight.
3. Install the 30- and 18-pin connectors to the EC-30™ controller ABS ECU, torquing the retaining cap screws to 15-20 in-lbs.
4. Apply ignition power and monitor the EC-30™ Controller power-up sequence and the LEDs on the ECU. Verify that only a green VLT LED is illuminated, no red LEDs. For all other Diagnostic Trouble Codes, including where reconfiguration is needed, see the Service Data sheet in this kit for full instructions.
5. Use sealing plugs to cover any unused wire harness terminals.
6. Check that all ECU connectors are completely seated and torqued correctly.
7. Perform the system check-out as outlined on page 3 of these instructions.

## GENERAL MAINTENANCE PRECAUTIONS

### WARNING! PLEASE READ AND FOLLOW THESE INSTRUCTIONS TO AVOID PERSONAL INJURY OR DEATH:

When working on or around a vehicle, the following general precautions should be observed at all times.

1. **Park the vehicle on a level surface, apply the parking brakes, and always block the wheels. Always wear safety glasses.**
2. **Stop the engine and remove ignition key when working under or around the vehicle. When working in the engine compartment, the engine should be shut off and the ignition key should be removed. Where circumstances require that the engine be in operation, EXTREME CAUTION should be used to prevent personal injury resulting from contact with moving, rotating, leaking, heated or electrically charged components.**
3. **Do not attempt to install, remove, disassemble or assemble a component until you have read and thoroughly understand the recommended procedures. Use only the proper tools and observe all precautions pertaining to use of those tools.**
4. **If the work is being performed on the vehicle’s air brake system, or any auxiliary pressurized air systems, make certain to drain the air pressure from all reservoirs before beginning ANY work on the vehicle. If the vehicle is equipped with an AD-IS® air dryer system or a dryer reservoir module, be sure to drain the purge reservoir.**
5. **Following the vehicle manufacturer’s recommended procedures, deactivate the electrical system in a manner that safely removes all electrical power from the vehicle.**
6. **Never exceed manufacturer’s recommended pressures.**
7. **Never connect or disconnect a hose or line containing pressure; it may whip. Never remove a component or plug unless you are certain all system pressure has been depleted.**
8. **Use only genuine Bendix® replacement parts, components and kits. Replacement hardware, tubing, hose, fittings, etc. must be of equivalent size, type and strength as original equipment and be designed specifically for such applications and systems.**
9. **Components with stripped threads or damaged parts should be replaced rather than repaired. Do not attempt repairs requiring machining or welding unless specifically stated and approved by the vehicle and component manufacturer.**
10. **Prior to returning the vehicle to service, make certain all components and systems are restored to their proper operating condition.**
11. **For vehicles with Antilock Traction Control (ATC), the ATC function must be disabled (ATC indicator lamp should be ON) prior to performing any vehicle maintenance where one or more wheels on a drive axle are lifted off the ground and moving.**

System Check-out	yes	no*
With the brake system fully charged with air, fully apply the service brakes and hold. Remove and apply ignition power. Does each PMV (modulator) exhaust air in the following pattern (SA Right, SA Left, DA Right, and DA Left)?		
Does each PMV exhaust air once per pattern (not twice)?		
Does the pattern of PMV exhausts repeat?		
Did the ABS indicator lamp illuminate for a period of approximately three seconds and then extinguish? (Assuming no diagnostic trouble codes are present.)		
Verify that only the green LED is illuminated. Any red LEDs that are illuminated indicate a diagnostic trouble code.		
With the power off, remove the 30 pin connector from the ECU. Key vehicle on. Does the ABS indicator lamp illuminate?		
Does the ABS indicator lamp illuminate as required when ABS is disabled due to a fault in the system?		
(Where an off-board diagnostic device is available for testing.) Is the ECU communicating over the J1587 link? (The J1587 link may not be connected to the ABS ECU.)		
Is the correct ECU installed? (Verify ECU part number)		
Are all Wheel Speed Sensors (WSS) wired properly to the ECU? (for example, SA Left WSS to SA Left WSS ECU input) Open each wheel speed sensor connection, making sure the correct component and location are displayed on the LEDs: Steer Axle Right Sensor Steer Axle Left Sensor Drive Axle Right Sensor Drive Axle Left Sensor		
Do all WSS have acceptable signal output (0.25 VAC @ 0.5 RPS)?		
Are all PMVs wired properly to the ECU? (for example, SA Left PMV REL to SA Left PMV REL ECU input) Open each modulator connection making sure the correct component and location are displayed on the LEDs: Steer Axle Right Modulator Steer Axle Left Modulator Drive Axle Right Modulator Drive Axle Left Modulator		
If the vehicle is equipped with a retarder relay, is the ECU configured to control the relay?		
Does the ECU perform ABS properly on each wheel? Where a test track or similar area is available, test drive the vehicle and make sure ABS is operating correctly.		

\*If any of the questions were answered with a "No", the Antilock system should be review by a qualified individual. For technical assistance, call the Bendix Technical Assistance Team at 1-800-AIR-BRAKE, (1-800-247-2725).

## CONTACTING BENDIX

[www.Bendix.com](http://www.Bendix.com)

The Bendix on-line troubleshooting guides help you determine the cause of most performance issues with the braking system. For additional troubleshooting information please see the Service Data sheet included in this kit.

The Bendix on-line contacts guide will make it easy for you to find the Bendix contacts you need. From this page, you can navigate to technical support contacts, Service Engineers, Bendix Account Managers, international contacts and more. Bendix.com is your complete Bendix resource.

### Bendix Technical Assistance Team

For direct personal technical support, call the Bendix technical assistance team at 1-800-AIR-BRAKE (1-800-247-2725-2-1), Monday through Friday, 8:00 A.M. to 6:00 P.M. EST, and follow the instructions in the recorded message.

Or, you may e-mail the Bendix technical assistance team at: [techteam@bendix.com](mailto:techteam@bendix.com).

To better serve you, please record the following information before calling the Bendix Tech Team:

Bendix product model number, part number and configuration.

Vehicle make and model.

Vehicle configuration. (Number of axles, tire size, etc.)

System performance symptoms. When do they occur?

What faults have been identified using blink codes or diagnostic tools?

What troubleshooting / measurements have been performed?

What Bendix service data literature do you have or need?

