

Bendix® XVision® Night Vision System

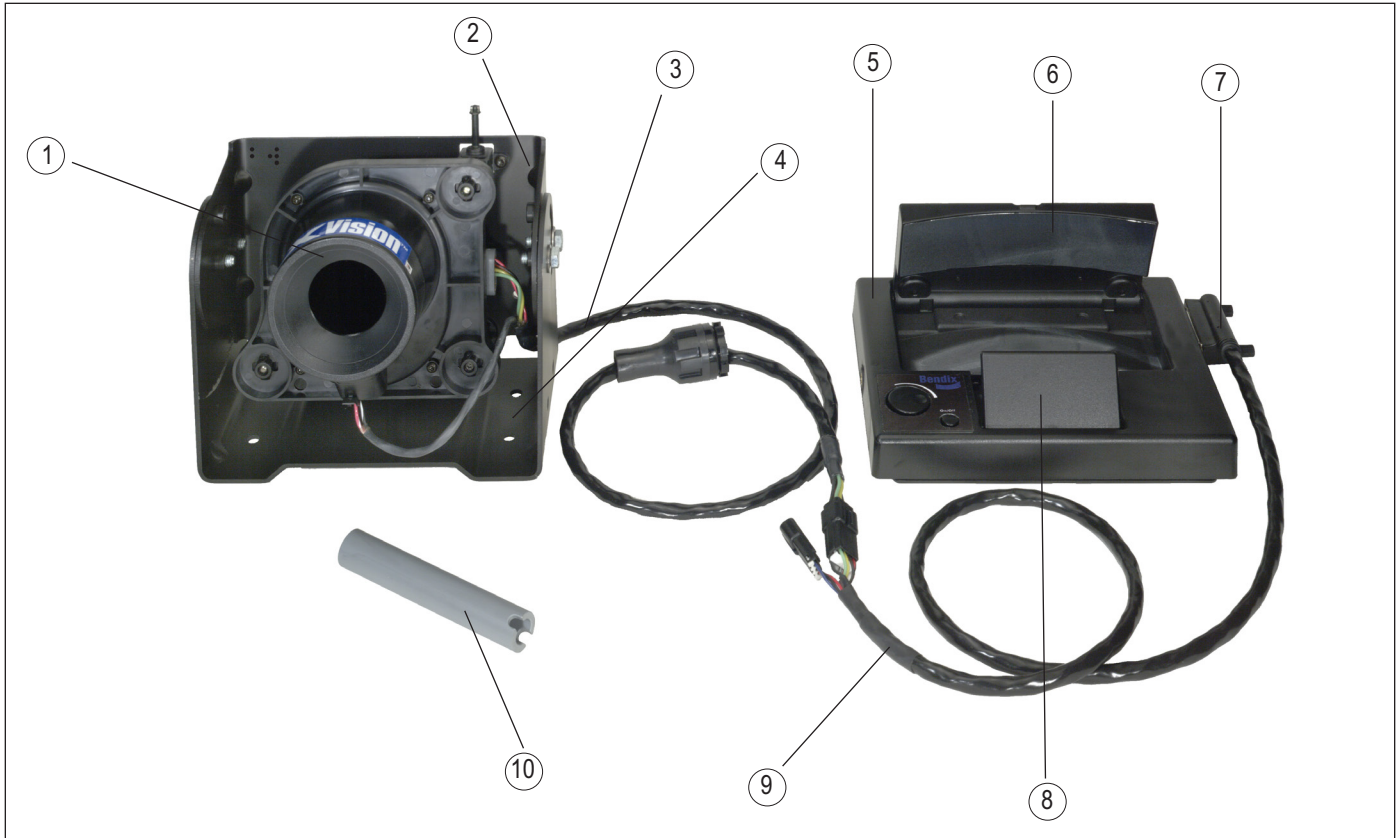

Bendix® XVision® Night Vision System (5010086) consists of:

Kit/ Part	Piece Number
Camera Bracket Kit	5010078
Mounting Kit (CB Mount)	5010081
Mounting Kit (Friction Hinge)	5010082
Harness Kit	5010083
Aiming Adjuster Tool	*
Camera/ Display Combination	*

* Kit/ Part is not serviceable and cannot be individually ordered through Bendix.

Item No.	Description	Qty.
1	IR Camera	1
2	IR Camera Bracket	1
3	IR Camera Harness	1
4	Mounting Bracket	1
5	Display	1
6	Combiner	1
7	25-Pin Connector	1
8	Fold Mirror	1
9	Display Harness**	2
10	Aiming Adjuster Tool	1

** The display harness shown is for the friction hinge mount (visor).

FIGURE 1 - BENDIX® XVISION® SYSTEM

Please note that this product is obsolete and parts/kits listed in this document are no longer serviceable through Bendix.

TABLE OF CONTENTS

SAFE MAINTENANCE PRACTICES	3
INTRODUCTION	3
COMPONENTS	3
IR CAMERA BRACKET KIT	4
CB STYLE MOUNTING KIT	5
FRICTION HINGE MOUNTING KIT	5
HARNESS KIT	6
AIMING ADJUSTER TOOL	8
IR CAMERA/DISPLAY COMBINATION	8
REPLACEMENT KITS	9
AIMING ADJUSTER REPLACEMENT	9
WINDOW REPLACEMENT	9
HEATER REPLACEMENT	9
COMBINER MIRROR REPLACEMENT	9
FOLD MIRROR REPLACEMENT	9
ELECTRICAL SYSTEM	10
POWER AND GROUND (INPUTS)	10
OPERATING INPUT VOLTAGE	10
SERVICING THE BENDIX® XVISION® SYSTEM	11
MOUNTING BRACKET	11
IR CAMERA BRACKET	11
IR CAMERA	12
IR CAMERA WINDOW	14
IR CAMERA WINDOW HEATER	15
DISPLAY	16
COMBINER	16
FOLD MIRROR	16
DISPLAY BRACKET	17
DISPLAY REPLACEMENT	18
HARNESSES	18
AIMING THE IR CAMERA	21
HORIZONTAL AIMING	21
VERTICAL AIMING	22
TROUBLESHOOTING	24

SAFE MAINTENANCE PRACTICES

WARNING! PLEASE READ AND FOLLOW THESE INSTRUCTIONS TO AVOID PERSONAL INJURY OR DEATH:

When working on or around a vehicle, the following general precautions should be observed at all times.

1. Park the vehicle on a level surface, apply the parking brakes, and always block the wheels. Always wear safety glasses.
2. Stop the engine and remove ignition key when working under or around the vehicle. When working in the engine compartment, the engine should be shut off and the ignition key should be removed. Where circumstances require that the engine be in operation, **EXTREME CAUTION** should be used to prevent personal injury resulting from contact with moving, rotating, leaking, heated or electrically charged components.
3. Do not attempt to install, remove, disassemble or assemble a component until you have read and thoroughly understand the recommended procedures. Use only the proper tools and observe all precautions pertaining to use of those tools.
4. If the work is being performed on the vehicle's air brake system, or any auxiliary pressurized air systems, make certain to drain the air pressure from all reservoirs before beginning **ANY** work on the vehicle. If the vehicle is equipped with a Bendix® AD-IS® air dryer system or a dryer reservoir module, be sure to drain the purge reservoir.
5. Following the vehicle manufacturer's recommended procedures, deactivate the electrical system in a manner that safely removes all electrical power from the vehicle.
6. Never exceed manufacturer's recommended pressures.
7. Never connect or disconnect a hose or line containing pressure; it may whip. Never remove a component or plug unless you are certain all system pressure has been depleted.
8. Use only genuine Bendix® brand replacement parts, components and kits. Replacement hardware, tubing, hose, fittings, etc. must be of equivalent size, type and strength as original equipment and be designed specifically for such applications and systems.
9. Components with stripped threads or damaged parts should be replaced rather than repaired. Do not attempt repairs requiring machining or welding unless specifically stated and approved by the vehicle and component manufacturer.

10. Prior to returning the vehicle to service, make certain all components and systems are restored to their proper operating condition.

11. For vehicles with Automatic Traction Control (ATC), the ATC function must be disabled (ATC indicator lamp should be ON) prior to performing any vehicle maintenance where one or more wheels on a drive axle are lifted off the ground and moving.

INTRODUCTION

The Bendix® XVision® Night Vision system is an infrared (IR) vision system for heavy vehicles. The system increases a driver's night visibility three to five times beyond the normal range of vehicle headlights, allowing earlier detection of hazards.

The system features an IR camera that detects electromagnetic energy in the 7-14 micron wavelength region and outputs a real-time monochrome video signal on a display. Objects emit radiation in this wavelength region, known as LWIR, which is proportional to temperature. The resulting video output is a thermal map of the forward road scene, where hotter objects appear brighter than cooler objects.

COMPONENTS

The XVision System (Piece No. 5010086) consists of the following six components, described on pages 3-7:

- IR Camera Bracket Kit (Piece No. 5010078)
- CB Style Mounting Kit (Piece No. 5010081)
- Friction Hinge Mounting Kit (Piece No. 5010082)
- Harness Kit (Piece No. 5010083)
- Aiming Adjuster Tool
- IR Camera/Display Combination

Parts/kits listed are now obsolete and are no longer serviceable through Bendix.

Parts/kits listed are now obsolete and are no longer serviceable through Bendix.

IR CAMERA BRACKET KIT (PIECE NO. 5010078) INCLUDES:

Mounting Bracket Kit (piece no. 5010187) – The mounting bracket is designed to mount to the vehicle roof (horizontal mounting) or faring area (vertical mounting) and needs to be mounted parallel to the lateral axis of the vehicle (side to side). A template is provided to help guide the drilling of holes. Two stud plates with 1/4-20 studs mount the bracket to the vehicle. The final torque on the studs should be 90-100 in-lbs.

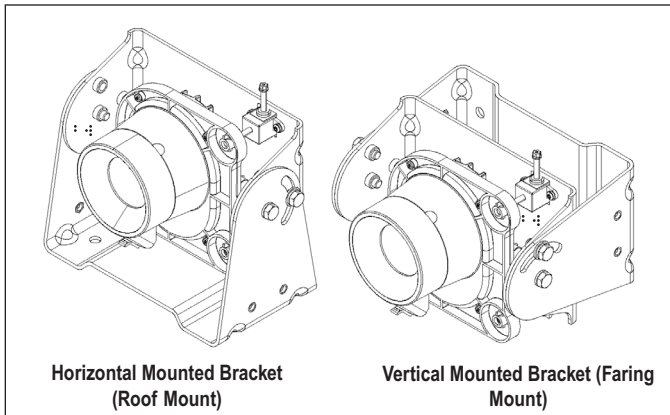

FIGURE 2 - MOUNTING BRACKET ORIENTATIONS

The mounting bracket kit also includes shims that should be used to level the mounting bracket. A sealant is to be used between the vehicle, mounting bracket, and stud plate. Verify that the sealant has been applied appropriately, according to the **Installation Instructions**. Additional mounting hardware is also included in the kit.

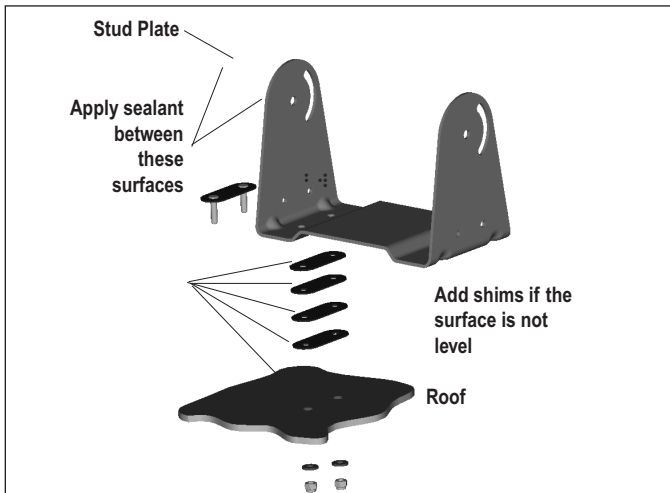

FIGURE 3 - MOUNTING BRACKET KIT CONTENTS

IR Camera Bracket with Aiming Adjusters (piece no. 5010673) – One IR camera bracket is provided in the IR camera bracket kit. The bracket includes a standoff base, standoff pivot assembly and aiming adjusters all of which are pre-installed.

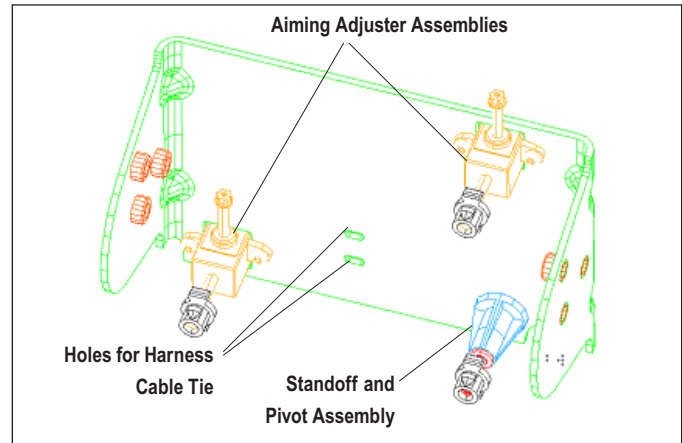

FIGURE 4 - IR CAMERA BRACKET WITH AIMING ADJUSTERS

Cable Tie – A cable tie (to fasten the IR camera harness to the IR camera bracket) is also included in the IR camera bracket kit.

Hardware – The IR camera bracket kit includes all of the necessary hardware to assemble the IR camera, IR camera bracket, and mounting bracket.

CB STYLE MOUNTING KIT (PIECE NO. 5010081)

The CB style mounting kit contains the necessary mounting hardware for the CB style dashboard option and CB style overhead option. When the display is mounted, the combiner surface (and virtual image) must be viewable in the driver's peripheral vision. A template is provided to help guide the drilling of holes.

The CB style mounting kit includes the following items.

Mounting brackets (piece no. 5009616) – The CB style mounting kit includes two mounting brackets that can be used for either the CB dashboard mount or CB overhead mount.

Parts/kits listed are now obsolete and are no longer serviceable through Bendix.

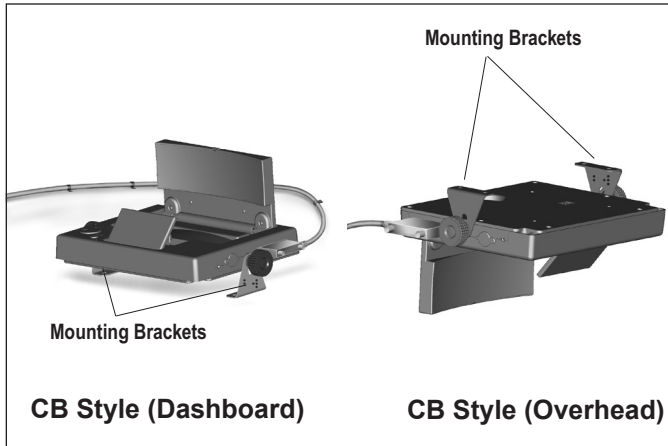

FIGURE 5 - CB MOUNTING BRACKETS

Knob kit (service piece no. 5010247) – The knob kit includes four 1/4 in. flat washers and two 1/4-20 threaded knobs, which are installed onto both sides of the display when it is mounted in the CB style.

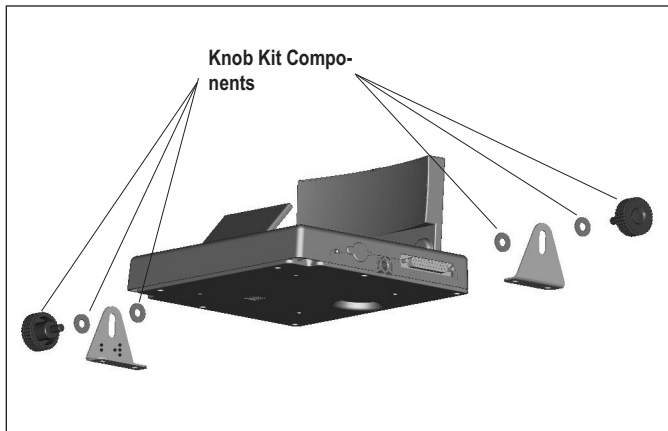

FIGURE 6 - KNOB KIT COMPONENTS

Plastite® screws – The CB style mounting kit includes four #10 Plastite® screws, each 1/2 in. long. Depending on the chosen CB mount, the screws are used to attach the mounting brackets to either the headliner or dashboard of the vehicle.

FRICITION HINGE MOUNTING KIT (PIECE NO. 5010082)

Friction hinge mounting allows the driver to use the sun visor during the day and the Bendix® XVision® Night Vision system at night. The display pivots on a pair of friction hinges, similar to a vehicle sun visor. The hinges allow the display to be flipped out of the way of the visor and latched into either position by use of a magnet and striker plates.

The friction hinge mounting kit includes the following items.

Hinge Supports – Two hinge supports secure the display to the vehicle headliner when the friction hinge mount is used. The hinge supports are fastened to the headliner with four #10 Plastite® pan head screws and to the display with two M2.5 threadroll pan head screws.

Magnet Kit (piece no. 5010524) – The magnet kit includes a magnet, striker plates, spring, and hardware. The magnet and spring are attached to the display, and one (1) striker plate is fastened to the vehicle headliner. The other striker plates (2) sandwich the sun visor.

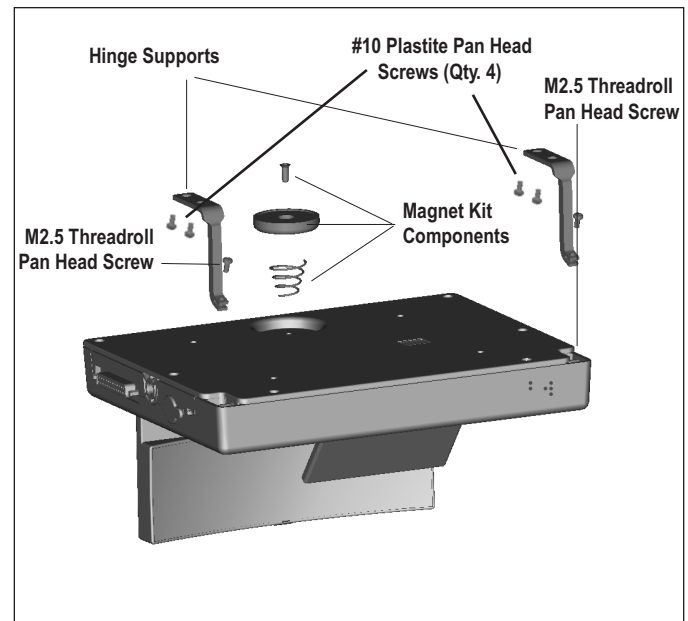

FIGURE 7 - FRICTION HINGE MOUNTING KIT COMPONENTS

Screw and Shim Kit (piece no. 5010249) – The screw and shim kit includes twelve #10 Plastite® pan head screws and twelve spacer blocks. The screws are used to fasten the friction hinge supports to the vehicle headliner and are supplied in three different lengths. The spacer blocks can be used to level the friction hinge supports, if necessary. Based on the number of spacers needed to level out the mount, use either the 1/2 in., 3/4 in., or 1 in. long screws.

Parts/kits listed are now obsolete and are no longer serviceable through Bendix.

HARNESS KIT (PIECE NO. 5010083)

The harness kit includes:

IR Camera Harness (piece no. 5010246, service piece no. 801156) – The IR camera harness is approximately three feet long and has three connectors. The 8-pin connector connects to the display harness, the 2-pin connector connects to the IR camera window heater, and the 6-pin connector connects to the IR camera power and video. See Figure 8 and Table 1 below.



FIGURE 8 - IR CAMERA HARNESS

TABLE 1 - IR CAMERA HARNESS PIN OUTS

Delphi Packard Connector 8 contacts Connector P/N 12047886 Terminal P/N 12047767		Delphi Packard Connector 6 contacts Connector P/N 12162856 Terminal P/N 12124075		Delphi Packard Connector 2 contacts Connector P/N 12162852 Terminal P/N 12124075	
A	IR Camera +	A	IR Camera +	A	Window Heater +
B	IR Camera -	B	IR Camera -	B	Window Heater -
C	Video Low	C	Video Low		
D	Video High	D	Video High		
E	Video Drain	E	Plug		
F	Not Used	F	Plug		
G	Window Heater -				
H	Window Heater +				

Display Harnesses (CB style: piece no. 5010259, service piece no. 801151; Friction Hinge: piece no. 5010263, service piece no. 801155) – The harness kit includes two display harnesses, one for CB style mounts and one for the friction hinge mounts. The harness for the CB style mounts exits toward the back of the display, and the harness for the friction hinge mount exits toward the front of the display. Both harnesses are three feet long. When installed, the display harness should be secured with a cable tie every three inches.

Both display harnesses have three connectors. The 25-pin connector connects to the display, the 3-pin connector connects to the vehicle harness, and the 8-pin connector connects to the IR camera harness. See Figure 9 and Table 2.

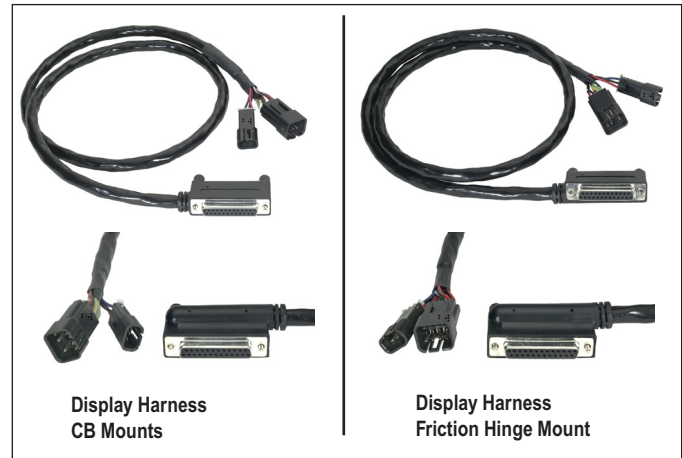

FIGURE 9 - DISPLAY HARNESSES

TABLE 2 - DISPLAY HARNESS PIN OUTS

Delphi Packard Connector 8 contacts Connector P/N 12045688 Terminal P/N 12059894		Delphi Packard Connector 3 contacts Connector P/N 12047782 Terminal P/N 12059894		D Subminiature 25 Contacts	
A	IR Camera +	A	Vehicle ign. +12V	2	Vehicle Ground
B	IR Camera Ground	B	Vehicle Ground	3	Video Low
C	Video Low	C	Headlamp Active	4	Video High
D	Video High			11	Headlamp Active
E	Video Drain			13	Vehicle ign. +12V
F	Not Used			14	IR Camera Ground
G	Window Heater -			15	Window Heater -
H	Window Heater +			16	Video Drain
				24	Window Heater +
				25	IR Camera +

Parts/kits listed are now obsolete and are no longer serviceable through Bendix.

Vehicle Harness (piece no. 5010260, service piece no. 801157) – The vehicle harness is approximately 12 feet long and provides power to the Bendix® XVision® Night Vision System. The harness is made of a twisted tri-wire, which needs to be fused to the vehicle ignition and headlamps. The harness has one 3-pin connector that connects to the display harness.

The vehicle harness is not designed to be mounted externally. After the harness is routed and secured with cable ties, the excess wire should be removed and the fuse holders installed. See Figure 10 and Table 3.



FIGURE 10 - VEHICLE HARNESS

TABLE 3 - VEHICLE HARNESS PIN OUTS

Delphi Packard Connector 3 Contacts Connector P/N 12047782 Terminal P/N 12059894		Fused	Color
A	Vehicle ignition +12 Volts	3 A slow open fuse (max.)	RED
B	Vehicle ground		BLACK
C	Headlamp active	1 A fast open fuse (max.)	BLUE

Harness Hardware – Two fuse holders, three butt splices, a 1 A fast open fuse and a 3 A slow open fuse are all included in the harness kit. Labels are also included and must be applied to the fuse holders after installation.

Jumper Harness (piece no. 5010441, service piece no. 801152) – The jumper harness acts as an “extension cord” when the display and IR camera are mounted more than six feet apart. The harness has two 8-pin connectors, one connects directly to the IR camera harness and the other to the display harness. The jumper harness is not designed to be mounted externally. See Figure 11 and Table 4.



FIGURE 11 - JUMPER HARNESS

TABLE 4 - JUMPER HARNESS PIN OUTS

Delphi Packard Connector 8 contacts Connector P/N 12045688 Terminal P/N 12059894		Delphi Packard Connector 8 contacts Connector P/N 12047886Terminal P/N 12047767	
A	IR Camera +	A	IR Camera +
B	IR Camera Ground	B	IR Camera -
C	Video Low	C	Video Low
D	Video High	D	Video High
E	Video Drain	E	Video Drain
F	Not Used	F	Not Used
G	Window Heater -	G	Window Heater -
H	Window Heater +	H	Window Heater +

Parts/kits listed are now obsolete and are no longer serviceable through Bendix.

AIMING ADJUSTER TOOL

The aiming adjuster tool is included with the Bendix® XVision® Night Vision System kit, but cannot be ordered individually. It is the only tool that should be used to install the IR camera onto the aiming adjusters.

IR CAMERA/ DISPLAY COMBINATION

The IR camera and display are serviceable and can be ordered individually. The IR camera/display combination can be purchased as an entire XVision system.

IR Camera (piece no. 5008214, service piece no. 801150) The IR camera must always be mounted externally to the vehicle and attaches to the standoff pivot assembly and aiming adjusters on the IR camera bracket. The IR camera is operational within the range of -40°C to 60°C.

The IR camera has two electrical connections: a 6-pin IR camera connector and a 2-pin window heater connector.

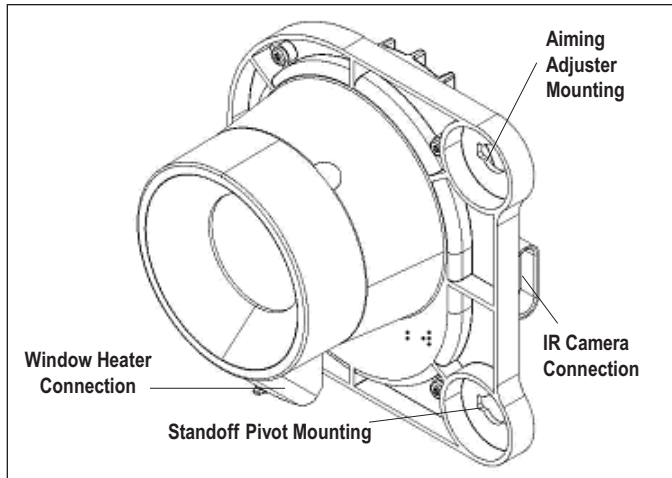

FIGURE 12 - IR CAMERA

Video Display (piece no. 5010210, service piece no. 801154) – The display is operational within the range of -40°C to 60°C. During power-up, the Bendix® icon will be displayed in the combiner for approximately 45 seconds. The intensity control will need to be adjusted according to light conditions and driver preference. After the initial warm-up, the IR camera’s field of view (FOV) will be displayed in the combiner.

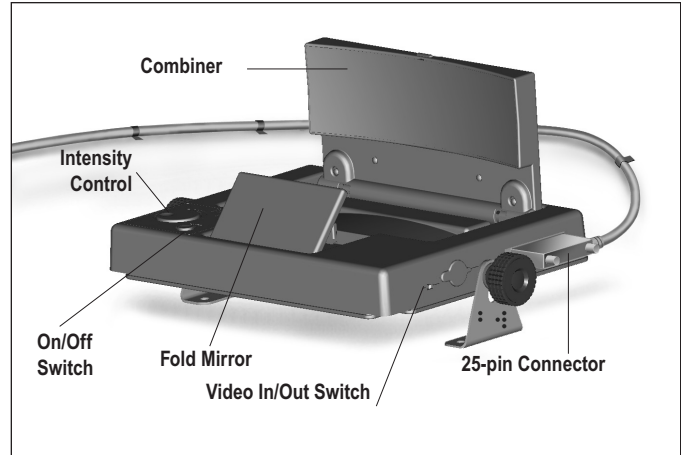

FIGURE 13 - DISPLAY (SHOWN IN CB STYLE MOUNT (DASHBOARD) POSITION WITH DISPLAY HARNESS)

The orientation of the virtual image on the display will depend on the display mounting style that you have chosen. On the bottom of the display, under a switch cover, there are four dual inline position (DIP) switches which allow you to rotate or invert the image. To access the DIP switches, slide the cover away from the 25-pin connector. Displays arrive from the factory with the DIP switches configured for the CB style dashboard mount. Refer to Table 5 for the DIP switch settings appropriate for your mount.

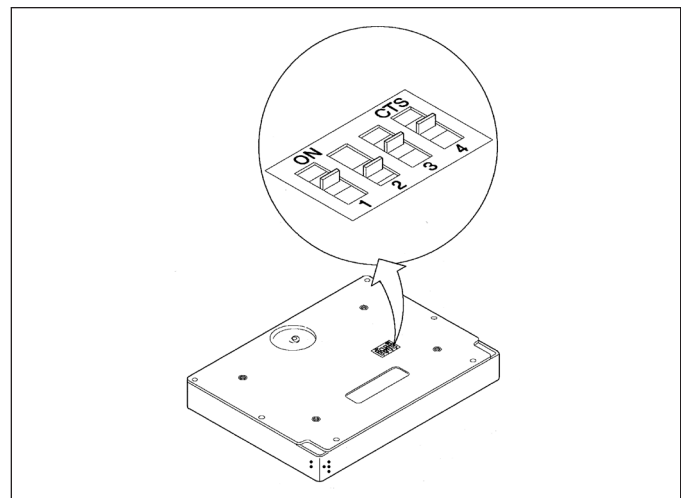

FIGURE 14 - DISPLAY DIP SWITCHES FOR DASHBOARD MOUNT

TABLE 5 - DIP SWITCH POSITIONS

Mounting Position	Video Format	DIP Switch Positions			
		1	2	3	4
Dash Mounted	(NTSC)	N/A	OFF	ON	ON
Overhead Mounted	(NTSC)	N/A	OFF	OFF	OFF

Parts/kits listed are now obsolete and are no longer serviceable through Bendix.

REPLACEMENT KITS

The following five kits contain replacement parts for the Bendix® XVision® Night Vision System. Each of the replacement kits can be ordered through Bendix.

For instructions on installing replacement parts, see the appropriate section of **Servicing the XVision System**, beginning on Page 10.

AIMING ADJUSTER REPLACEMENT KIT (PIECE NO. 5010079)

The IR camera bracket can only be ordered as a component of the IR camera bracket kit. However, the components that attach to the IR camera bracket to aim and adjust the IR camera can each be ordered in the aiming adjuster replacement kit. The kit includes the items below.

Standoff pivot assembly (QTY 1) – fastens to the IR camera standoff base with a maximum torque of 16 in-lbs.

Standoff base (QTY 1) – fastens to the IR camera bracket with #10 Plastite® Hex® flange head screw and lockwasher with a maximum torque of 18-20 in-lbs.

Aiming adjusters (QTY 2) – latch the IR camera into position on the IR camera bracket and allow the IR camera forward Field of Vision (FOV) to be adjusted horizontally and/or vertically. The adjustment screw head(s) accommodate an E8 external Torx® or a T15 internal Torx® tool. (The aiming adjusters are fastened to the IR camera bracket and torqued to 18 in-lbs. with four #8-32 Hex®/Torx® screws.)

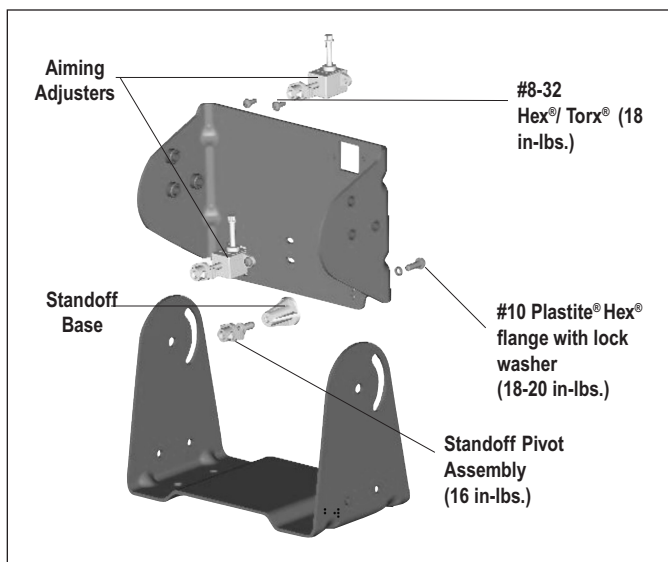

FIGURE 15 - AIMING ADJUSTER REPLACEMENT KIT

WINDOW REPLACEMENT KIT (PIECE NO. 5010192)

The window replacement kit includes one replacement IR camera window, o-ring and locking pin. See Figure 16.

HEATER REPLACEMENT KIT (PIECE NO. 5010193)

The heater replacement kit includes one replacement IR camera heater and locking pin. See Figure 16.

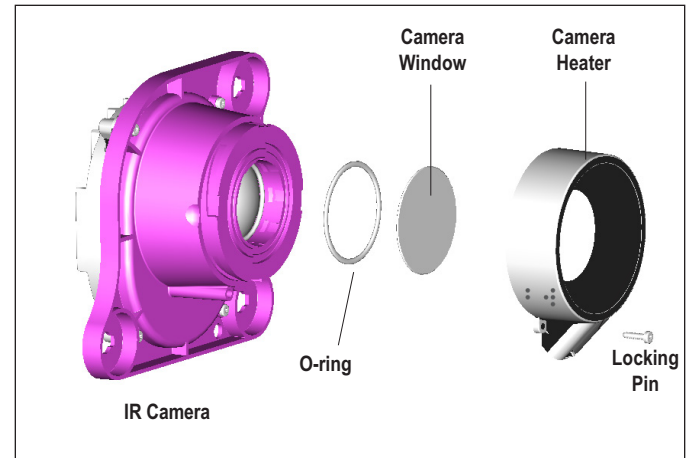

FIGURE 16 - IR CAMERA AND CAMERA HEATER

COMBINER MIRROR REPLACEMENT KIT (PIECE NO. 5010190)

The combiner mirror replacement kit includes one replacement combiner. See Figures 17 & 28.

FOLD MIRROR REPLACEMENT KIT (PIECE NO. 5010189)

The fold mirror replacement kit contains one replacement fold mirror. See Figures 17 & 29.

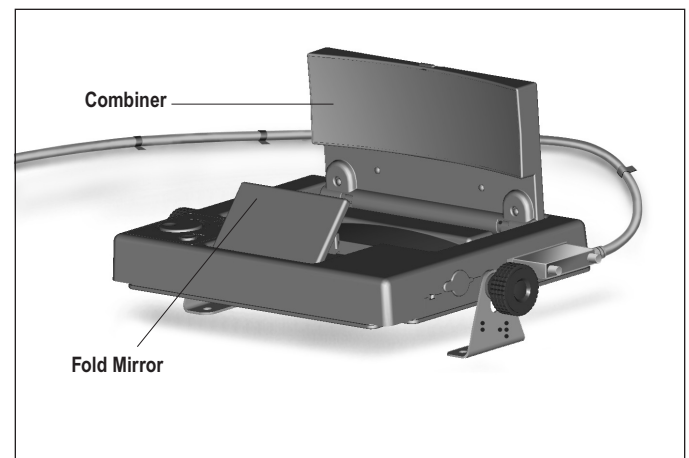

FIGURE 17 - COMBINER AND FOLD MIRROR

Parts/kits listed are now obsolete and are no longer serviceable through Bendix.

ELECTRICAL SYSTEM

POWER AND GROUND (POWER INPUTS)

Electrical power to the Bendix® XVision® Night Vision System is provided through the vehicle harness. The vehicle ignition wire {(A) Red} should be fused to a 3 A slow open fuse (maximum) and connected to the ignition bus of the vehicle. The ground wire {(B) black} should be connected to the ground bus of the vehicle. The headlamp active wire {(C) blue} should be fused to a 1 A fast open fuse (maximum) and connected to the vehicle headlamp circuit. When the headlamps are on, 12V should be present on the blue wire.

WARNING: Vehicle power and headlight circuits **MUST** be fused. Permanent damage to the display, IR camera, or vehicle electrical system could occur if power to these units is not fused. Eliminating fuses from circuit will void all warranties.

IMPORTANT: When replacing a fuse, it is important to use only the specified fuse with the correct amperage, as listed above. The use of a fuse with a rating other than indicated may result in a dangerous electrical system overload. Repeated opening of a properly rated fuse indicates a problem in the circuit that must be corrected.

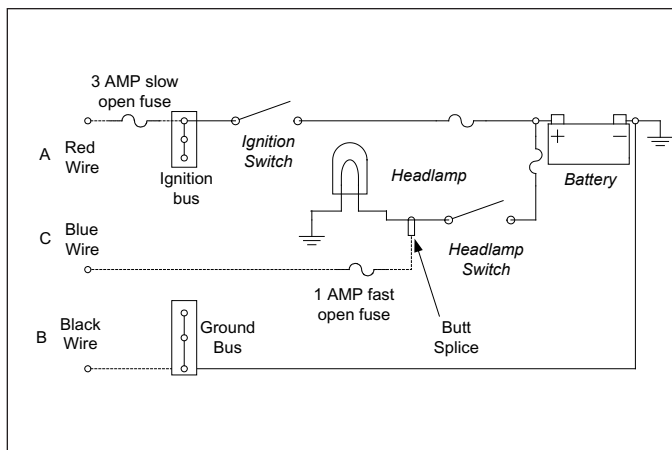

FIGURE 18 - XVISION SYSTEM ELECTRICAL SCHEMATIC

The IR camera and display are compatible with 12V DC battery systems with a chassis ground.

OPERATING INPUT VOLTAGE

The IR camera is operational in the temperature range between -40°C to 60°C . Normally, the IR camera takes about 45 seconds to warm up. However, as the external temperature gets closer to the extremes listed, the warm-up time will begin to approach two minutes. Refer to Figure 19.

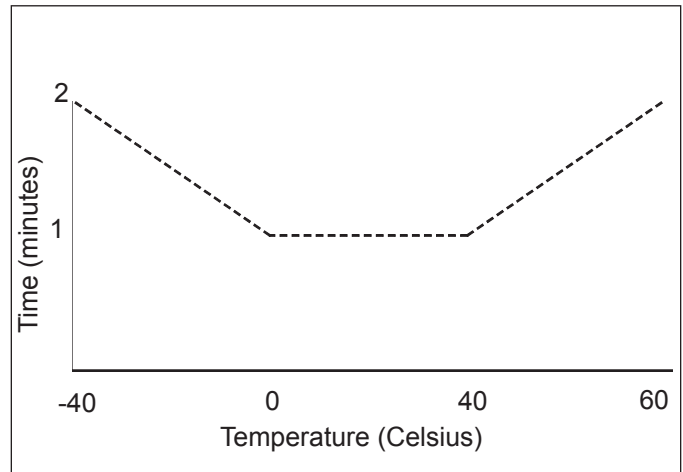

FIGURE 19 - OPERATIONAL TEMPERATURE RANGE AND WARM-UP TIME OF IR CAMERA

SERVICING THE XVISION SYSTEM

The following sections provide instructions for maintaining and/or replacing components of the XVision system.

CAMERA MOUNTING BRACKET REPLACEMENT

1. Loosen and remove the four 5/16 in. bolts securing the IR camera bracket to the mounting bracket.
2. Disconnect the camera harnesses (2-pin and 6-pin). Remove the IR camera assembly.
3. From inside the cab, remove all mounting hardware from the mounting bracket.
4. Remove the stud plates, mounting bracket, and shims (if used).
5. Clean the area around the drilled holes in the cab.
6. Align the new mounting bracket with the holes in the cab. Note: use new mounting hardware for the installation.

Parts/kits listed are now obsolete and are no longer serviceable through Bendix.

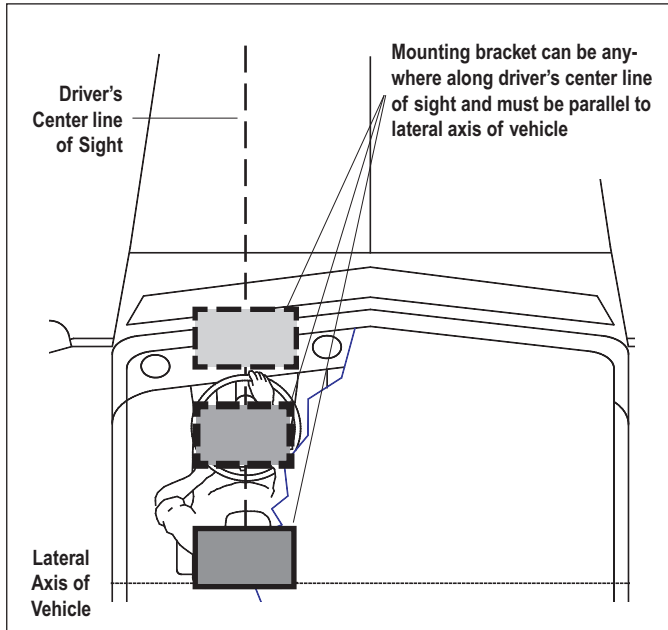

FIGURE 20 - MOUNTING BRACKET AND LATERAL AXIS OF VEHICLE

7. Verify that the mounting bracket is level. If it is not, use the shims included in the mounting bracket kit.
8. Apply sealant between all contact areas (between the roof and the shims, between each shim, between the shims and the bracket, and between the bracket and stud plates).
9. Install the stud plates on both sides of the replacement mounting bracket.
10. From inside the cab, tighten all mounting hardware to 90-100 in-lbs.
11. Insert the four 5/16 in. bolts through the mounting bracket into the new IR camera bracket and hand tighten. Allow enough mobility for adjustments to be made during the aiming procedure.
12. Reconnect the 2-pin and 6-pin harnesses.
13. Aim and adjust the IR camera. Refer to **Aiming the IR Camera** on Pages 21-22.

IR CAMERA BRACKET REPLACEMENT

The new IR camera bracket will have factory-installed aiming adjusters and standoff base/pivot assembly.

1. Remove the camera shroud, if equipped. Unlock the IR camera by turning the two IR camera aiming adjusters and the IR camera standoff 1/4 turn counterclockwise using the adjuster tool.

2. Disconnect the IR camera connector (6-pin) and the window heater connector (2-pin) of the IR camera harness.
3. Remove the IR camera and IR camera harness from the IR camera bracket. The IR camera harness should be tied to the bracket with a cable tie. Cut the tie to remove the harness.
4. Loosen and remove the four 5/16 in. bolts from the IR camera bracket.
5. Remove the old IR camera bracket.
6. Place the new IR camera bracket in the same location as the old.
7. Insert the four 5/16 in. bolts through the mounting bracket and new IR camera bracket into the threaded inserts, and hand-tighten.
8. Replace the camera shroud.

Attach the IR camera harness

9. Pull the IR camera harness through the opening between the IR camera bracket and mounting bracket.
10. Plug the 2-pin connector of the IR camera harness into the window heater. Refer to Figure 21.
11. Plug the 6-pin connector of the IR camera harness into the IR camera connection. Refer to Figure 21.
12. Loosely install the harness cable tie around the harness.

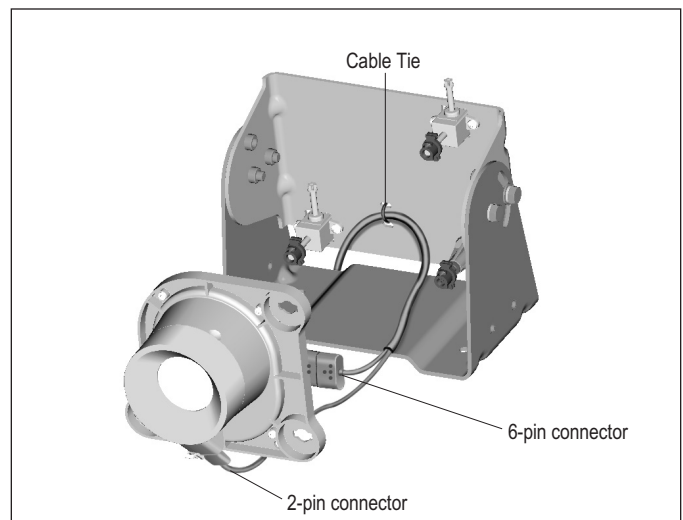

FIGURE 21 - CONNECTING THE CAMERA HARNESSSES

Parts/kits listed are now obsolete and are no longer serviceable through Bendix.

Attach the IR camera to the IR camera bracket

13. Position the IR camera onto the factory-installed aiming assemblies. Refer to Figure 22.
14. Rotate the pivot locks on the ends of the aiming assemblies 1/4 turn clockwise, using the included aiming adjuster tool. This will lock the IR camera in position.
15. Adjust the harness, ensuring that it is not pulled tight, which could cause a water leak into the camera. Securely tighten the harness cable tie to prevent wire chaffing from the bracket.
16. Aim and adjust the IR camera. Refer to **Aiming the IR Camera** on pages 21 and 22.

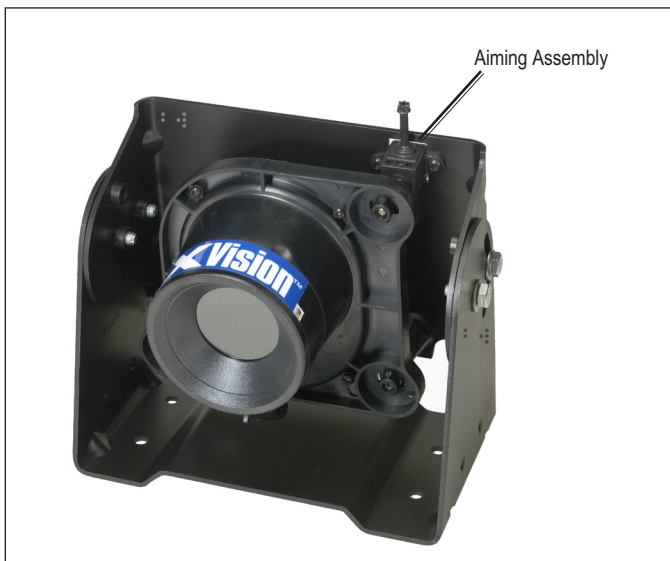

FIGURE 22 - FULLY ASSEMBLED IR CAMERA

IR CAMERA

Maintaining

The IR camera weighs approximately 2 lbs. Conduct the following maintenance inspections on a regular basis.

1. Inspect the harnessing for chafing.
2. Inspect mounting for loose bolts.
3. Inspect aiming adjusters for cracks or breaks. Replace as necessary.
4. Inspect and clean the camera window.

Replacing IR Camera

1. Unlock the IR camera by turning the two IR camera aiming adjusters and the IR camera standoff 1/4 turn counterclockwise.
2. Remove the IR camera from the IR camera bracket to get easier access to the connectors.
3. Disconnect the 6-pin IR camera connector and the 2-pin window heater connector of the IR camera harness from the IR camera.
4. Install new camera. Plug the 2-pin connector of the IR camera harness into the window heater. Refer to Figure 23.

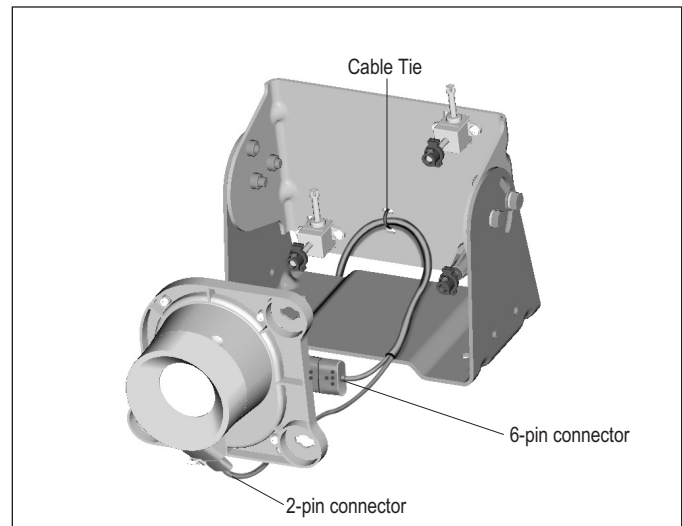

FIGURE 23 - CONNECTING THE IR CAMERA HARNESSES

5. Plug the 6-pin connector of the IR camera harness into the IR camera connection. Refer to Figure 23.
6. Position the IR camera onto the factory-installed aiming adjusters.
7. Rotate the pivot locks (on the ends of the aiming adjusters) 1/4 turn clockwise, using the included aiming adjuster tool. This will lock the IR camera in position.

Parts/kits listed are now obsolete and are no longer serviceable through Bendix.

Replacing the Aiming Adjusters

1. Unlock the IR camera by turning the two IR camera aiming adjusters and the IR camera standoff 1/4 turn counterclockwise.
2. Remove the IR camera from the IR camera bracket to get easier access to the connectors.
3. Disconnect the 6-pin IR camera connector and the 2-pin window heater connector of the IR camera harness from the IR camera. Cut the cable tie to allow access. Refer to Figure 24.

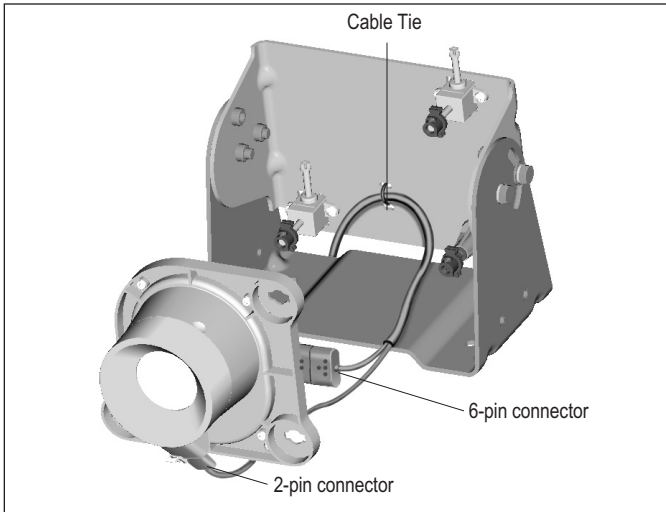

FIGURE 24 - CONNECTING THE CAMERA HARNESSES

4. Remove the #8-32 Hex[®]/Torx[®] screws from the damaged aiming adjuster(s). Refer to Figure 25.
5. Remove the Plastite[®] Hex[®] flange head screw and #10 lock washer from the damaged standoff pivot assembly.

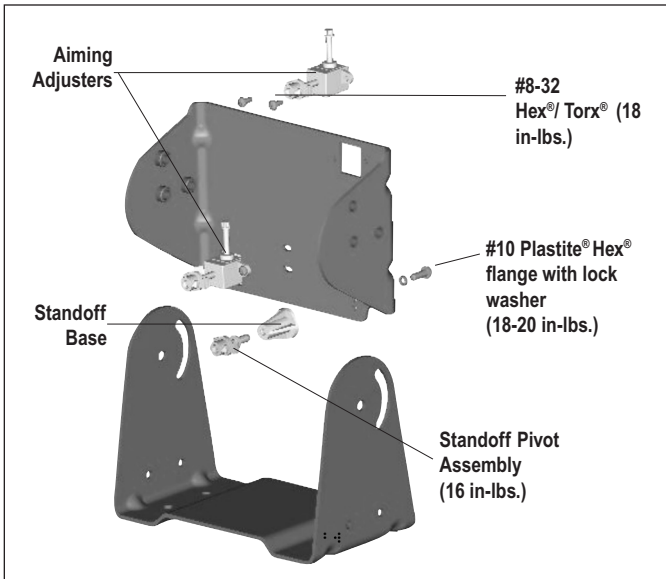

FIGURE 25 - AIMING ADJUSTER REPLACEMENT KIT COMPONENTS

6. Replace the damaged parts with the new aiming adjusters and standoff pivot assembly that were received with the service kit (piece no. 5010079).

NOTE: The IR camera bracket can only be ordered as a component of the IR camera bracket kit. However, the components that attach to the IR camera bracket to aim and adjust the IR camera can each be ordered in the aiming adjuster replacement kit. The kit includes the items below.

Standoff pivot assembly (QTY 1) – fastens to the IR camera standoff base with a maximum torque of 16 in-lbs.

Standoff base (QTY 1) – fastens to the IR camera bracket with #10 Plastite[®] Hex[®] flange head screw and lockwasher with a maximum torque of 18-20 in-lbs.

Aiming adjusters (QTY 2) – latch the IR camera into position on the IR camera bracket and allow the IR camera forward FOV to be adjusted horizontally and/or vertically. The adjustment screw head(s) accommodate an E8 external Torx[®] or a T15 internal Torx[®] tool. (The aiming adjusters are fastened to the IR camera bracket and torqued to 18 in-lbs. with four #8-32 Hex[®]/Torx[®] screws.

7. Install the new aiming adjuster(s) using the #8-32 Hex[®]/Torx[®] screws. Torque the screws to 18 in-lbs.
8. Install the new standoff pivot assembly using the #10 lock washer and Plastite[®] Hex[®] flange head screw. Torque the screw to 16 in-lbs.

Parts/kits listed are now obsolete and are no longer serviceable through Bendix.

IR CAMERA WINDOW

Maintaining

The IR camera window, a 1.3 mm thick silicon disk, is an optical element and should be cleaned when it becomes dirty or filled with debris. Dirt and debris can affect the IR camera performance.

To clean the window, use a soft, damp cloth moistened with window cleaning solution. Shop rags and paper towels will scratch optical surfaces.

NOTE: The IR camera heater cannot melt large amounts of packed snow in the window area. It is recommended that the snow be removed manually prior to system operation. When cleaning ice or snow from the IR camera, use a commercially available spray deicer; do not use scrapers or sharp instruments that may scratch or break the window.

Replacing

If the window cracks or breaks, it must be replaced.

1. Unlock the IR camera assembly by turning the two IR camera aiming adjusters and the standoff pivot assembly 1/4 turn counterclockwise.
2. Remove the IR camera from the IR camera bracket to gain easier access to the connectors.
3. Disconnect the 6-pin IR camera connector and the 2-pin window heater connection of the IR camera harness from the IR camera.
4. Lay the IR camera face-up for easy access to the bezel retaining plug. Refer to Figure 26.
5. Remove the bezel retaining plug.
6. Turn the bezel heater assembly 1/4 turn counterclockwise, until it separates from the IR camera.
7. Replace the damaged window and seal.

NOTE: The replacement window is treated with a black scratch-resistant coating on one side only. The side that appears black must face the environment.

NOTE: If the area between the IR camera window and IR camera lens is contaminated because of a damaged seal or window, carefully remove the contamination. If a window cleaning solvent is used to clean the area, be sure to remove all of the moisture from the sealed cavity before assembling the o-ring seal and window. Moisture remaining in the sealed area will affect the performance of the IR camera.

NOTE: Use care when removing shards of glass.

8. Turn the bezel heater assembly 1/4 turn clockwise to reattach it to the IR camera. Note: Ensure the window is positioned correctly or it can be damaged when installing the bezel.
9. Lock the bezel heater assembly in place with the bezel retention plug.
10. Plug the 2-pin connector of the IR camera harness into the window heater. Refer to Figure 24 on page 12.
11. Plug the 6-pin connector of the IR camera harness into the IR camera connection. Refer to Figure 24 on page 12.
12. Position the IR camera onto the factory-installed aiming assemblies.
13. Rotate the pivot locks on the end of the aiming assemblies 1/4 turn clockwise, using the aiming adjuster tool. This will lock the IR camera in position.
14. Aim and adjust the IR camera. Refer to **Aiming the IR Camera** on pages 21 and 22.

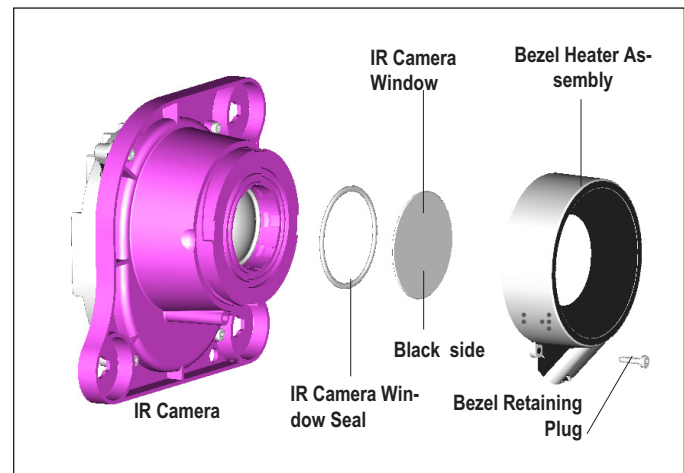

FIGURE 26 - IR CAMERA WINDOW AND BEZEL RETAINING PLUG

Parts/kits listed are now obsolete and are no longer serviceable through Bendix.

IR CAMERA WINDOW HEATER REPLACEMENT

1. Unlock the IR camera by turning the two IR camera aiming adjusters and the IR camera standoff 1/4 turn counterclockwise.
2. Remove the IR camera from the IR camera bracket to gain easier access to the connectors.
3. Disconnect the 6-pin IR camera connector and the 2-pin window heater connector of the IR camera harness from the IR camera.
4. Lay the IR camera face-up for easier access to the bezel retaining plug. Refer to Figure 27.
5. Remove the bezel retaining plug.
6. Turn the bezel heater assembly 1/4 turn counterclockwise, until it separates from the IR camera. Use care to prevent the window from falling and breaking.
7. Turn the new bezel heater assembly 1/4 turn clockwise onto the IR camera. Note: Ensure the window has not moved or it will be damaged.
8. Lock the new heater in position with the bezel retaining plug.
9. Plug the 2-pin connector of the IR camera harness into the window heater. Refer to Figure 24.
10. Plug the 6-pin connector of the IR camera harness into the IR camera connection. Refer to Figure 24.
11. Position the IR camera onto the factory-installed aiming assemblies.
12. Rotate the pivot locks on the end of the aiming assemblies 1/4 turn clockwise, using the aiming adjuster tool. This will lock the IR camera in position.
13. Aim and adjust the IR camera. Refer to **Aiming the IR Camera** on pages 21 and 22.

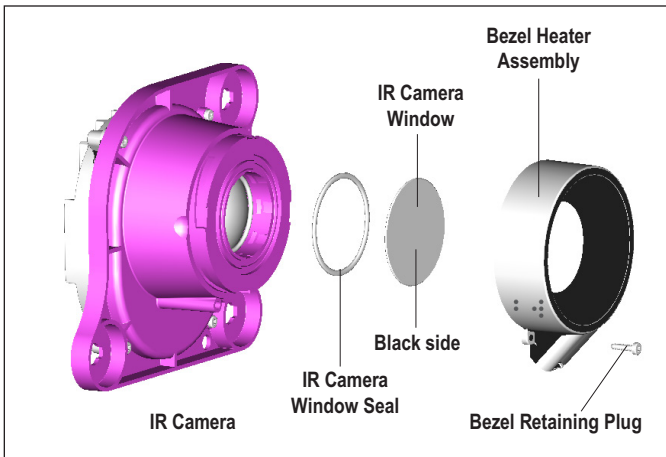

FIGURE 27 - BEZEL HEATER ASSEMBLY AND RETAINING PLUG

Parts/kits listed are now obsolete and are no longer serviceable through Bendix.

DISPLAY

Maintaining the Combiner Mirror

The combiner is a sensitive optical element and should be cleaned when it becomes dirty or filled with debris. Dirt and debris can affect the display performance.

1. Remove heavy dirt or grit with air.
2. Clean the combiner with a soft, damp cloth moistened with window cleaning solution. Shop rags and paper towels will scratch this optical surface.

NOTE: Do not use ammonia to clean any of the display components. It will remove scratch-resistant and anti-glare coatings.

Replacing the Combiner Mirror

1. Locate the depression in the center of the combiner door. Refer to Figure 28.

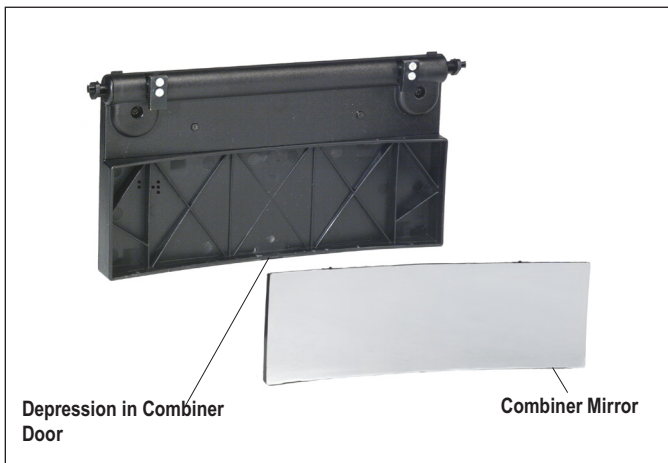

FIGURE 28 - REPLACEMENT COMBINER

2. Pry the old combiner out by inserting a small screwdriver or pocket knife into the depressions and pushing upward.
3. Snap the new combiner gently in place.

Maintaining the Fold Mirror

Remove heavy dirt or grit from the fold mirror with air. Clean the fold mirror with a soft, damp cloth moistened with window cleaning solution. Shop rags and paper towels will scratch this optical surface.

NOTE: Do not use ammonia to clean any of the display components. It will remove scratch-resistant and anti-glare coatings.

Replacing the Fold Mirror

1. Locate one of the four depressions along the perimeter of the fold mirror. Refer to Figure 29.

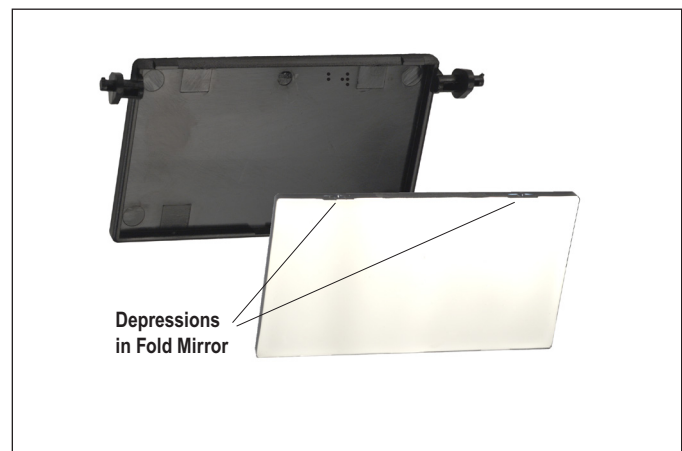

FIGURE 29 - REPLACEMENT FOLD MIRROR

2. Pry the old fold mirror out by inserting a small screwdriver or pocket knife into one of the depressions and pushing upward.
3. Snap the new fold mirror gently into place.

Parts/kits listed are now obsolete and are no longer serviceable through Bendix.

Display Bracket Replacement - CB Style Mount (Dashboard)

1. Unscrew and disconnect the 25-pin connector of the display harness.
2. Unscrew the threaded knobs from the display and brackets. Set the display, knobs, and washers aside. Exercise care to prevent dropping the washers into the venting on the dash.
3. Remove the four #10 Plastite® pan head screws from the brackets and dashboard. Set the four screws aside.
4. Secure the replacement brackets with the four screws from Step 3.
5. Torque the screws to approximately 20 in-lbs.
6. Slide one of the washers onto one of the threaded knobs.
7. Hold one washer between the display and a bracket while threading the washer/knob from the outside of the bracket. See Figure 30.

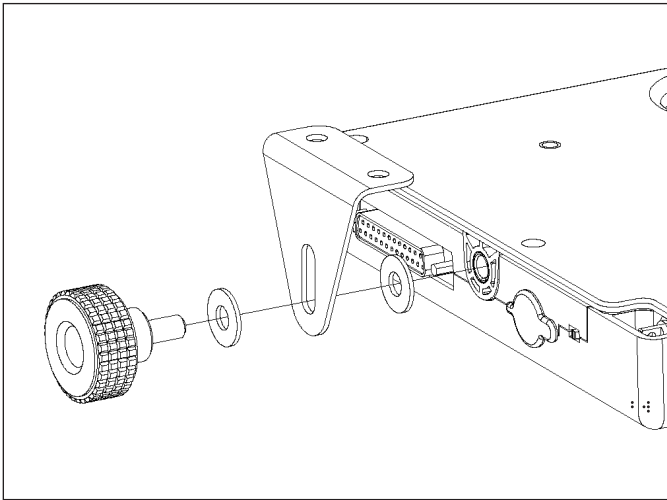

FIGURE 30 - WASHERS AND THREADED KNOBS [SHOWN IN CB STYLE MOUNT (OVERHEAD) POSITION]

8. Repeat steps 6 and 7 for the other side of the display.
9. Reconnect the 25-pin connector of the display harness.

Display Bracket Replacement - CB Style Mount (Overhead)

Refer to **CB Style Mount (Dashboard)** procedure.

Display Bracket Replacement - Friction Hinge Mount (Visor)

1. Unscrew and disconnect the 25-pin connector of the display harness.
2. Flip the display down to allow access to the friction hinge supports.
3. Remove the four #10 Plastite® pan head screws that secure the display to the headliner.
4. Remove the two M2.5 threadroll pan head screws that secure the friction hinge supports to the display.
5. Secure the new friction hinge supports to the display with the M2.5 threadroll pan head screws.

IMPORTANT: Do not exceed 15 in-lbs. when fastening. If 15 in-lbs. are exceeded, the screw head will shear off or the standoffs will strip. The threadroll screws will form threads in the standoffs as they are tightened. If it feels as though the screw is binding, back out the screw slightly and continue to tighten to prevent breakage.

6. Secure the new friction hinge supports to the headliner with the four #10 Plastite® pan head screws. Torque the screws to approximately 15 in-lbs.
7. Reconnect the 25-pin connector of the display harness.

Base Plate 8-32 Mounting

Four 8-32 inserts are provided in the display base. A template is provided to help guide the drilling of holes. Use a 13/64 in. bit for drilling the four clearance holes. Typically, this installation is used when the display is being recessed.

Display Replacement

IMPORTANT: The display is not waterproof and should not be exposed to rain, snow, or moisture. Under extreme conditions, water may enter the circuitry through the panel buttons. In general, treat the display as you would a pocket calculator or other small non-waterproof electronic instrument.

IMPORTANT: The Bendix® XVision® Night Vision System display technology is designed to meet severe temperature extremes. However, when installing the display for head-down operation or for use in extremely warm climates, take necessary precautions to shield the unit from direct sunlight. Prolonged exposure to direct sunlight in enclosed truck cabs can damage the system.

CB Style Mount (Dashboard and/or Overhead)

1. Unscrew and disconnect the 25-pin connector of the display harness.
2. Unscrew the threaded knobs from the display and brackets. Refer to Figure 30. Set the knobs and washers aside.
3. Remove the old display.
4. Set the DIP switches on the new display according to Table 5 on Page 7.
5. Slide one of the washers onto one of the threaded knobs.
6. Hold one washer between the new display and a bracket while threading the washer/knob from the outside of the bracket. Refer to Figure 30 on Page 15.
7. Repeat steps 5 and 6 for the other side of the display.
8. Plug the 25-pin connector of the display harness into the new display.

Friction Hinge Mount (Visor)

1. Disconnect the 25-pin connector of the display harness.
2. Flip the display down to allow access to the friction hinge supports.
3. Remove the four #10 Plastite® pan head screws that secure the display to the headliner.
4. Remove the old display.
5. Remove the two M2.5 threadroll pan head screws that secure the friction hinge supports to the display.
6. Secure the friction hinge supports to the new display with the two M2.5 threadroll pan head screws.

IMPORTANT: Do not exceed 15 in-lbs. when fastening. If 15 in-lbs. are exceeded, the screw head will shear off or the standoffs will strip. The threadroll screws will form the threads on the standoffs as

they are tightened. If it feels as though the screw is binding, back out the screw slightly and continue to tighten to prevent breakage.

7. Secure the friction hinge supports to the headliner with the four #10 Plastite® pan head screws.
8. Torque the screws to approximately 15 in-lbs.
9. Connect the 25-pin connector of the display harness to the new display.

HARNESS REPLACEMENT

Each of the XVision System harnesses is replaceable and can be ordered through Bendix. Refer to Figure 43 on page 22 for more detailed information regarding the electrical wiring of the system.

IR camera Harness

1. Remove the trim pieces covering the harness and the cab headliner in areas covering the IR camera harness.
2. Disconnect the 8-pin connector of the IR camera harness from the display harness.
3. Turn the two IR camera aiming adjusters and the IR camera standoff pivot assembly 1/4 turn.
4. Remove the IR camera from the IR camera bracket to gain easier access to the connectors.
5. Disconnect the IR camera connector (6-pin) and the window heater connector (2-pin) of the IR camera harness.
6. Cut the cable tie that secures the IR camera harness to the IR camera mounting bracket.
7. From inside the cab, remove the externally threaded nut from the harness.
8. Remove the IR camera harness from the cab.
9. Remove the externally threaded nut from the heat shrinkable shroud assembly on the replacement harness.
10. From inside the cab, push the threaded nut through the hole in the roof.

NOTE: The threaded section of the nut should protrude past the vehicle surface. Refer to Figure 31.

11. Place the o-ring over the externally threaded end.
12. Thread the harness through the externally threaded nut.
13. Fasten the heat shrinkable shroud onto the nut.
14. Hand-tighten the shroud from the outside of the roof.
15. Torque the heat-shrinkable shroud with a spanner

Parts/kits listed are now obsolete and are no longer serviceable through Bendix.

wrench to approximately 15 to 20 in-lbs. or until the o-ring is slightly flattened.

16. Route the IR camera harness to the "A" pillar of the cab.
17. Connect the 8-pin connector of the IR camera harness to the display harness.

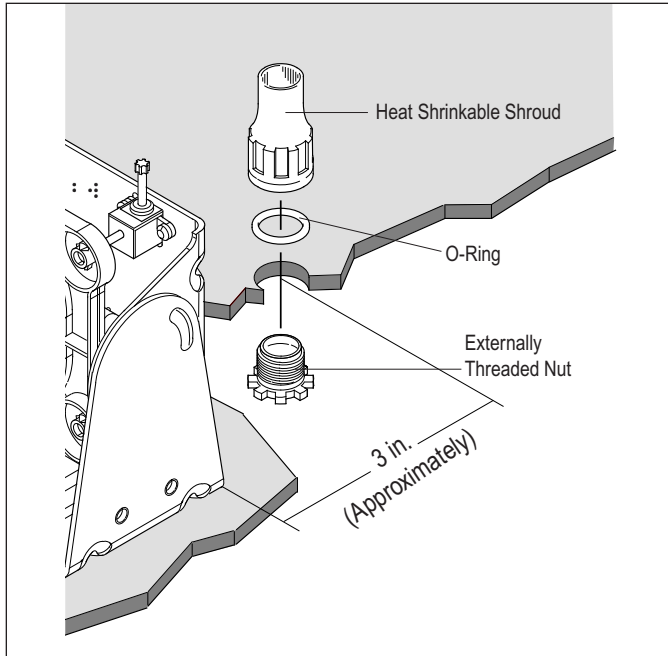

FIGURE 31 - HEAT SHRINKABLE SHROUD ASSEMBLY

18. Pull the IR camera harness through the opening between the IR camera bracket and mounting bracket.
19. Plug the 2-pin connector of the IR camera harness into the window heater. Refer to Figure 32.
20. Plug the 6-pin connector of the IR camera harness into the IR camera connection. Refer to Figure 32.

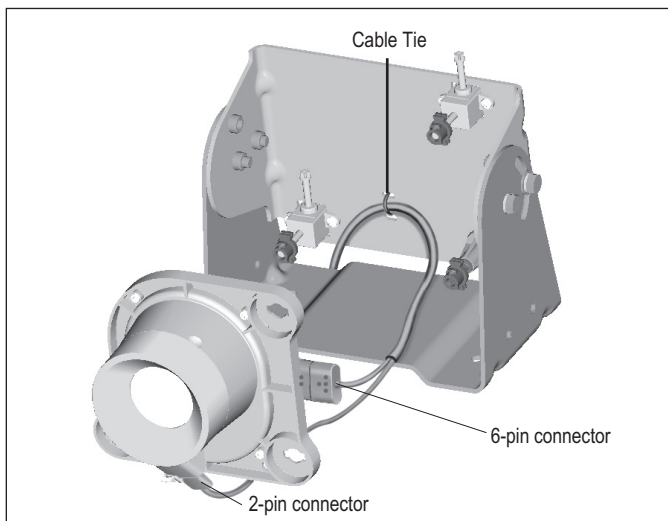

FIGURE 32 - CONNECTING THE CAMERA HARNESSSES

21. Loosely install the harness tie-wrap around the harness.
22. Position the IR camera onto the factory-installed aiming assemblies. Refer to Figure 33.
23. Rotate the pivot locks on the ends of the aiming assemblies 1/4 turn clockwise using the included aiming adjuster tool. This will lock the IR camera in position.

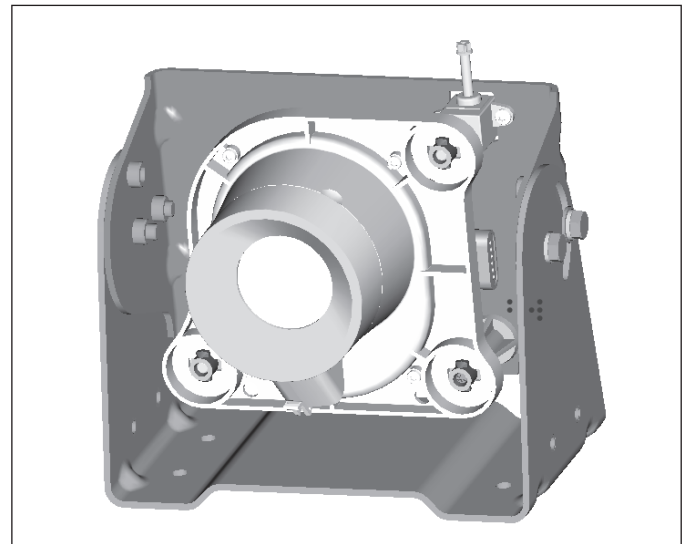

FIGURE 33 - FULLY ASSEMBLED CAMERA

24. Securely tighten the harness cable tie.
25. Ensure that the harness reaches the "A" pillar without trouble. Once the shroud assembly is heat-shrunk, the harness cannot be moved or adjusted.
26. After the IR camera harness is properly secured and routed, heat-shrink the shroud assembly from the outside of the vehicle, using a heat gun.

WARNING: Do not touch the shroud assembly after it has been heat-shrunk. It will be hot and may cause burns.

IMPORTANT: Be careful not to melt the wiring or o-ring during the heat shrinking process.

Parts/kits listed are now obsolete and are no longer serviceable through Bendix.

27. Re-install the headliner and the "A" pillar cover.
28. Turn on the system to verify that it is operating correctly.
29. Aim and adjust the IR camera. Refer to **Aiming the IR Camera** on pages 20 and 21.

Display Harness

1. Unscrew and disconnect the 25-pin connector of the display harness.
2. Remove the trim pieces covering the harness.
3. Disconnect the display harness from the 8-pin IR camera harness connector and the 3-pin vehicle harness connector.
4. Remove any fasteners securing the display harness.
5. Connect the new display harness as follows:
 - the 3-pin connector to the vehicle harness.
 - the 8-pin connector to the IR camera harness.
 - the 25-pin connector to the display.
6. Turn on the system to verify that it is operating correctly.
7. Replace the "A" pillar cover.
8. Secure the new display harness every 3 in. with cable ties.

Vehicle Harness

WARNING: Improper installation of the vehicle harness can cause damage to your vehicle's wiring and/or to the Bendix® XVision® Night Vision System. It is the responsibility of the installer to review wiring and service information for the vehicle and to identify proper locations for connecting the vehicle harness to the power. Many modern vehicles have additional, built-in fused accessory power breakouts and these breakouts should be used if at all possible.

1. Remove the trim pieces covering the harness.
2. Disconnect the vehicle harness from the display harness.
3. Remove the red wire (A-contact) from the ignition bus.
4. Remove the blue wire (C-contact) that is butt-spliced between the headlamp and the headlamp switch.
5. Remove the black wire (ground) from the ground bus.
6. Remove any fasteners securing the vehicle harness.
7. Remove the old vehicle harness.
8. Strip the three ends of the new vehicle harness.
9. Connect the red wire (A-contact) of the new vehicle harness to the ignition bus with a 3 A slow open fuse.

TABLE 6 - VEHICLE HARNESS WIRING

Vehicle Harness Connector 3 Contacts	Fused	Color	
A	Vehicle ignition +12 Volts	3 A slow open fuse (max.)	RED
B	Vehicle ground		BLACK
C	Headlamp active	1 A fast open fuse (max.)	BLUE

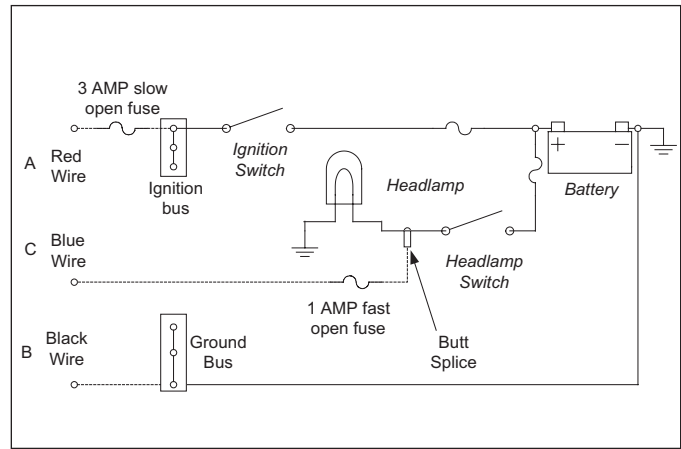

FIGURE 34 - XVISION SYSTEM ELECTRICAL POWER SCHEMATIC

10. Butt splice the blue wire (C-contact) of the new vehicle harness between the headlamp and the headlamp switch with a 1 A fast open fuse.
11. Connect the black wire to the ground bus.
12. Route the new vehicle harness to the display harness and connect them.
13. Turn the system on to verify that it is operating correctly.
14. Secure the new vehicle harness every 6-12 in. with cable ties.
15. Replace the "A" pillar cover.

Jumper Harness

1. Remove any fasteners securing the jumper harness.
2. Disconnect the jumper harness from the IR camera harness and the display harness.
3. Connect the replacement jumper harness to the IR camera harness and the display harness.
4. Turn the system on to verify that it is operating correctly.
5. Secure the new jumper harness every 6-12 in. with cable ties.

Parts/kits listed are now obsolete and are no longer serviceable through Bendix.

AIMING THE IR CAMERA

The aiming adjusters on the IR camera bracket allow the forward field of view (FOV) of the IR camera to be adjusted horizontally and vertically. The adjustment screw head(s) will accommodate an E8 external Torx® or a T15 internal Torx®.

When the IR camera is mounted, adjust the horizontal and vertical aiming adjusters to align the IR camera FOV with the display. The position of the virtual image on the display and how the virtual image correlates to objects in the road depends directly on IR camera aiming.

NOTE: Use two people to aim and adjust the IR camera. One technician should view the virtual image on the display while the other technician aims the IR camera.

NOTE: Verify that the vehicle is level and that the tires are properly inflated before beginning the IR camera aiming procedure.

HORIZONTAL AIMING AND ADJUSTING

When the IR camera is not mounted directly above the driver, the angle of the IR camera will need to be adjusted. Align the display image horizontally with the objects in the road to give the driver a sense of object location.

1. Using Figures 35-38 and a T15 Torx wrench, adjust the angle of the IR camera as needed.

NOTE: Two and one-quarter turns of the horizontal adjuster is equal to one degree of IR camera movement.

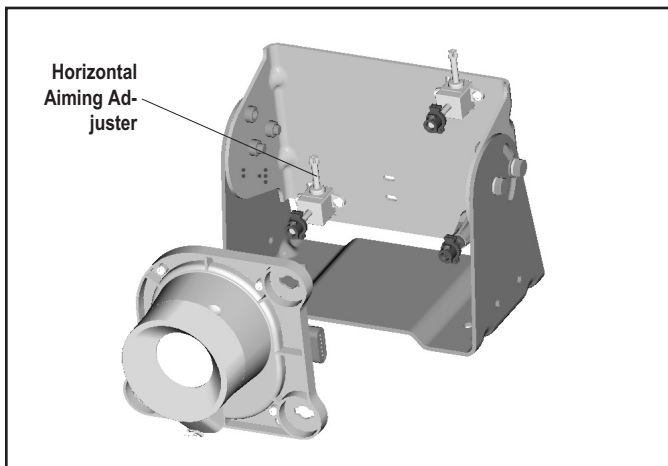

FIGURE 35 - HORIZONTAL AIMING ADJUSTER

NOTE: Do not tamper with or adjust any factory-installed screws while aiming the camera. Only turn the horizontal aiming adjuster.

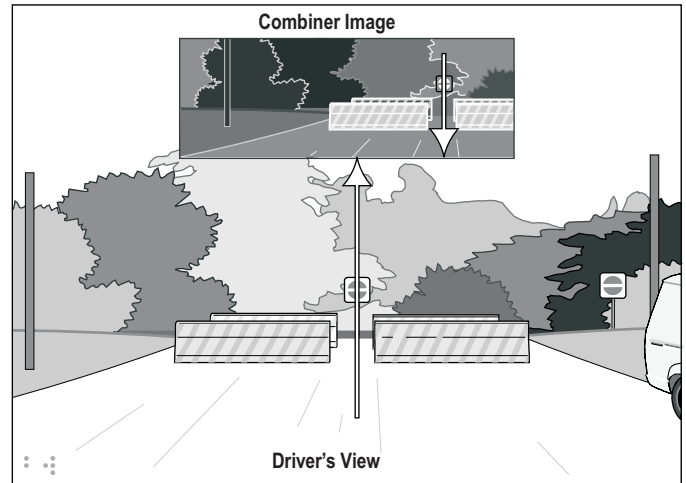

FIGURE 36 - IR CAMERA AIMED TOO FAR LEFT

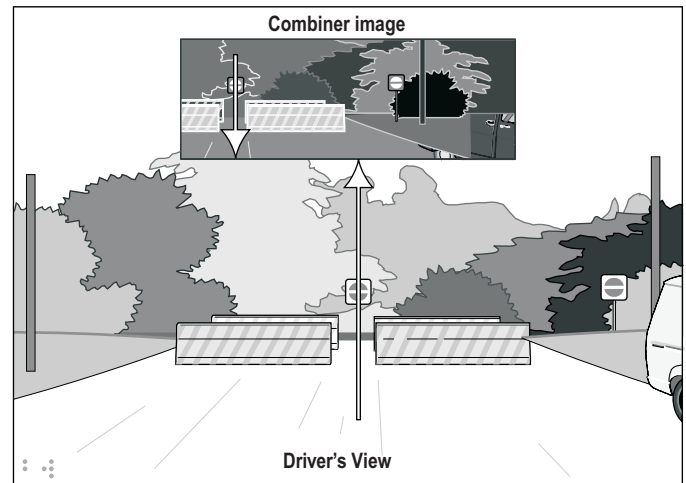

FIGURE 37 - IR CAMERA AIMED TOO FAR RIGHT

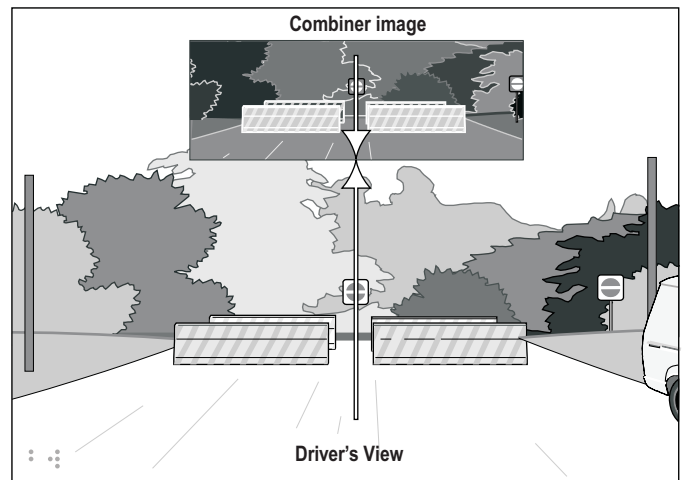

FIGURE 38 - IR CAMERA AIMED CORRECTLY

Parts/kits listed are now obsolete and are no longer serviceable through Bendix.

VERTICAL AIMING AND ADJUSTING

The virtual image should be aligned vertically so that the horizon appears in the lower one-half to one-third of the combiner. Keeping the image at this adjustment should provide a view of the road when the vehicle is driven up and down hills.

The vertical aiming adjusters can accommodate approximately ± 4 degrees of movement. If the IR camera needs more than 4 degrees of vertical movement the IR camera bracket will need to be adjusted. Before changing the vertical aiming adjuster, make sure the 5/16 bolts of the IR camera bracket are tightened to 90-100 in.-lbs.

1. Using Figures 39 - 42 and a T15 Torx wrench, adjust the angle of the IR camera as needed.

NOTE: Two turns of the vertical adjuster is equal to one degree of IR camera movement.

NOTE: It is recommended that the IR camera adjusters be aimed to view approximately 200 ft (61m) in front of the vehicle. Any thermal objects closer than 200 feet will already be illuminated by the low beam headlamps.

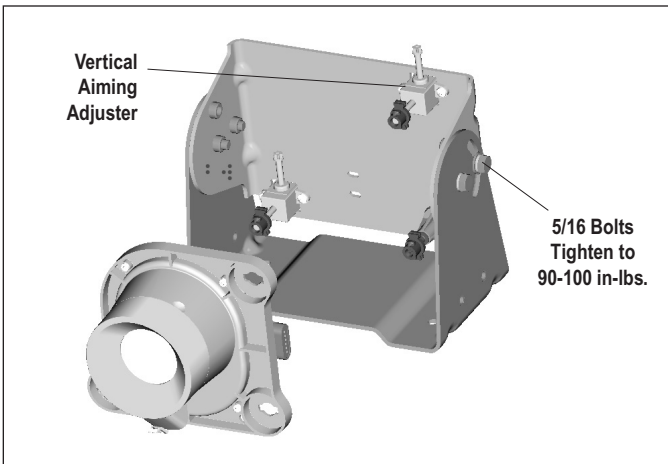

FIGURE 39 - VERTICAL AIMING ADJUSTER

NOTE: Do not tamper with or adjust any factory-installed screws while aiming the camera. Only turn the vertical aiming adjuster.

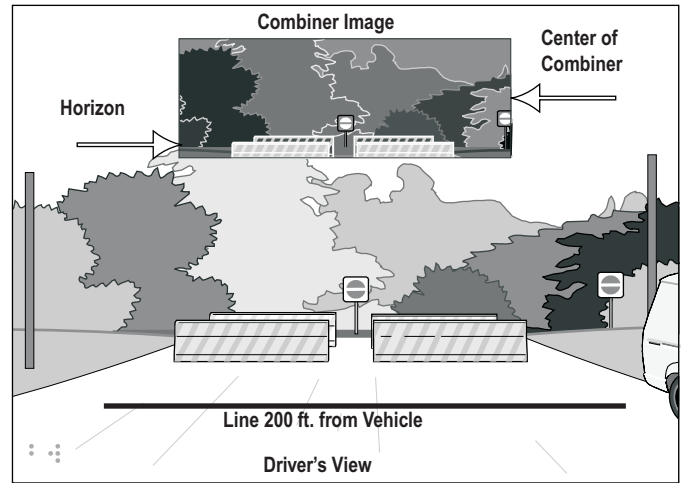

FIGURE 40 - IR CAMERA AIMED TOO HIGH

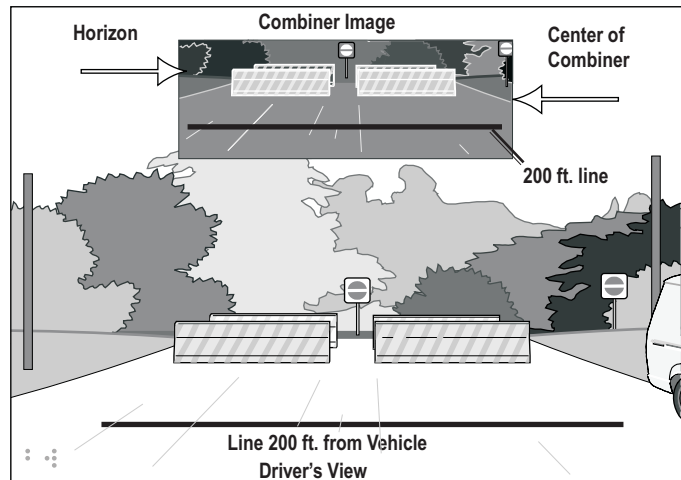

FIGURE 41 - IR CAMERA AIMED TOO LOW

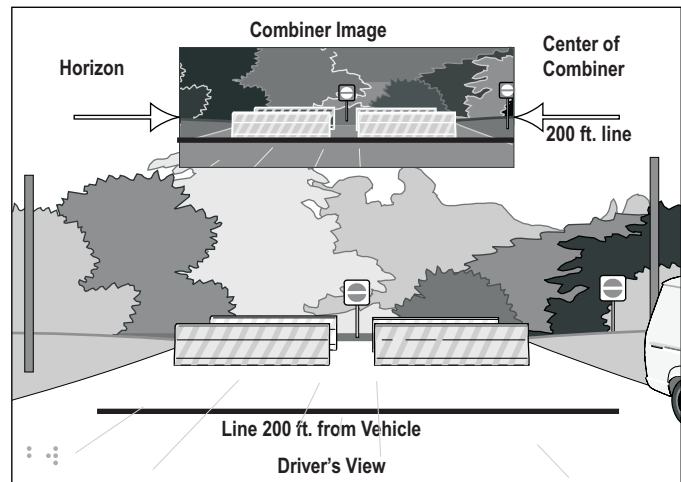

FIGURE 42 - IR CAMERA AIMED CORRECTLY

IR Camera and Notebook Display Schematic

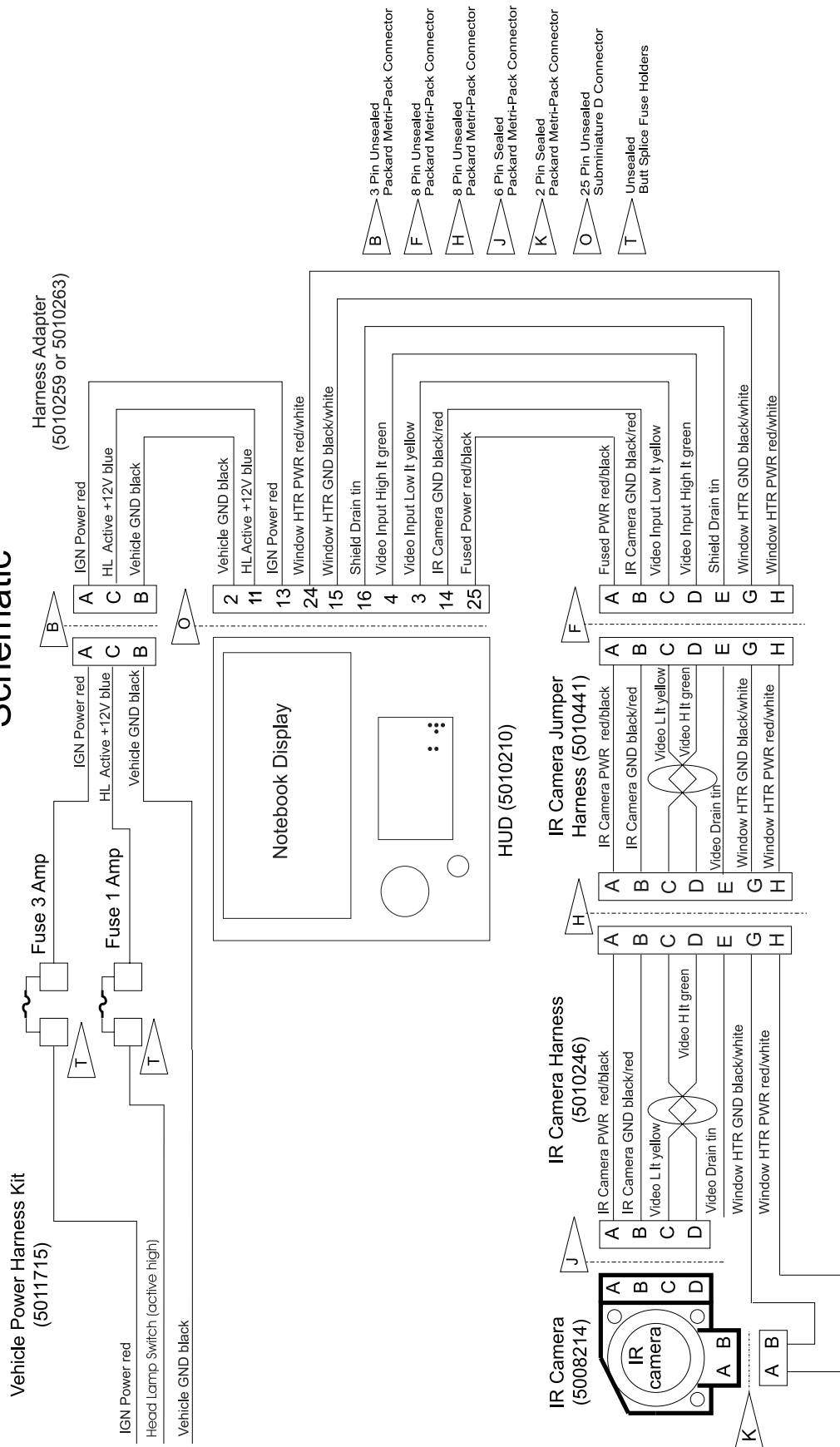



FIGURE 43 - ELECTRICAL WIRING DIAGRAM FOR BENDIX® XVISION® NIGHT VISION SYSTEM

TROUBLESHOOTING

Troubleshooting Your Bendix® XVision® Night Vision System

Situation	Possible Solutions		
<p>No image on the display. Bendix logo does not appear during power-up, combiner and fold mirror are open.</p>	Check that the combiner is open to an angle that allows you to see the image.		
	Make sure the vehicle accessory power, headlights, and the XVision system are all on.		
	Check that the display intensity is set at an appropriate level to view the image.		
	Check that the 25-pin connector of the display harness is completely plugged into the display and fastened.		
	Check the 25-pin display harness connections, reference XVision system schematic, figure 43 on page 23 @ (C)		
	25-pin	Description	Voltage
	2	Vehicle Ground	ground
11	Headlamp	+ 12 Volts	
13	Ignition	+ 12 Volts	
<p>Incorrect voltage value, ignition, headlamp, ground, at 25-pin connector.</p>	Check that the 3 A slow open fuse connecting the red wire of the vehicle harness to the 12V battery is intact. Check that there is 12 Volts at this location, using a multimeter.		
	Check that the 1 A fast open fuse connecting the blue wire of the vehicle harness to the head lamp circuit is intact. With headlamps on, check that there is 12 Volts at this location, using a multimeter.		
	Check the ground connection of the vehicle harness.		
	Check the 3-pin vehicle harness connections, reference XVision system schematic, figure 43, on page 23 @ (A)		
	3-Pin	Description	Voltage
	A	Ignition	+ 12 Volts
	B	Vehicle Ground	ground
C	Headlamp	+ 12 Volts	
<p>Bendix logo remains on the display after 2 minutes.</p>	Check that the video in/out switch is set to “out.” Reference figure 13 on page 7.		
	Check that the 6-pin camera harness connector is plugged completely into the IR camera, reference figure 21 on page 10. Check that the terminals are seated and the wiring secure.		
	Check the 6-pin IR camera harness connections (2 pins not used), reference XVision system schematic, figure 43 on page 23 @ (H)		
	6-Pin	Description	Voltage
	A	IR camera power	+ 12 Volts
	B	IR camera ground	ground
	Check to see if the IR camera harness 8-pin connector is plugged into the display harness 8-pin connector. Reference figures 8 & 9 on page 5.		

Situation	Possible Solutions		
IR camera image is not displayed after the Bendix logo fades away on the display.	Wait two minutes after the Bendix® XVision® Night Vision System has been powered to view the IR camera image.		
	Check to see if the IR camera window is blocked.		
	Headlamps were turned off and the XVision system timed out (approximately 7 seconds after the headlamps are turned off the display will turn off.)		
	Check to see if the IR camera is aimed correctly.		
Display image is upside down.	Check that DIP switch 4 is set correctly. Reference figure 14 on page 8.		
Display image is reversed, right to left.	Check that DIP switch 3 is set correctly. Reference figure 14 on page 8.		
The display image is difficult to view.	Check to see if the display intensity is set correctly.		
	Check that the combiner is open to an angle that allows you to see the image.		
	Check to see if the combiner, fold mirror, and LCD are clean.		
	Check to see if the IR camera window is cracked. Moisture between the window and lens will limit image quality.		
Snow build up on the IR camera window with the Bendix® XVision® Night Vision System powered.	Check the 2-pin IR camera harness connector is plugged into the IR camera heater. Reference figure 21 on page 11.		
	Check that the terminals are seated and the wiring is secure.		
	Check the 2-pin IR camera harness connections. Reference the XVision system schematic, figure 43 on page 23 @ 		
	2-pin	Description	Voltage
	A	IR camera heater power	+ 12 Volts
	B	IR camera heater power	ground

Please note that this product is obsolete and parts/kits listed in this document are no longer serviceable through Bendix.

For any inquiries regarding this system, call the Bendix technical assistance team at **1-800-AIR-BRAKE** (1-800-247-2725), Monday through Friday, 8:00 A.M. to 6:00 P.M. EST.

Alternatively, you may e-mail the Bendix Tech Team at: techteam@bendix.com.

