

BENDIX® TRSP® (TRAILER ROLL STABILITY PROGRAM) DATA SHEET

NOTE: Bendix® TRSP® on towing A-train requires prior approval from Bendix Engineering

NOTE: Mechanical suspension applications require prior approval from Bendix Engineering

Trailer Manufacturer:

Fleet Customer:

Work Order:

From S/N:

To S/N:

Trailer Type:

(if trailer is not easy to describe, please provide sketches)

Desired Antilock Braking System (ABS) Configuration:

2S/1M

Bendix® TABS-6™ Advanced Only

2S/2M

TABS-6 Advanced Multi-Channel Only

4S/2M

TABS-6 Advanced Multi-Channel Only

Semi-Trailer

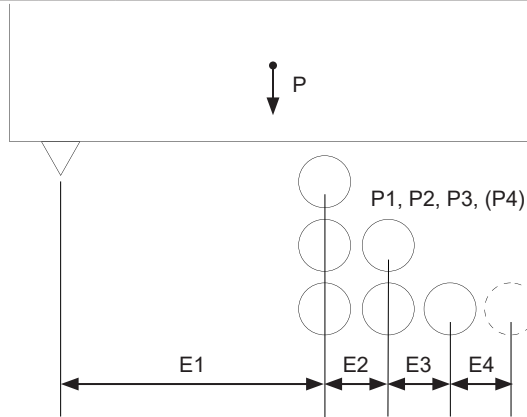

Weight Data		Payload Empty (lb _f)		Fully Loaded (lb _f) at GAWR
Total Weight	P			
Weight Axle 1 (Load Scale)	P1			
Weight Axle 2 (Load Scale)	P2			
Weight Axle 3 (Load Scale)	P3			
Weight Axle 4 (Load Scale)	P4			
Wheel Base (in.):	E1:	E2:	E3:	E4:
Tone Ring: (default 100 teeth)	Track Width (in.): (default 78.5 in.)			
Tire	Make:	Model #:	Diameter (in.): (default 39.4 in.)	
Tire Type:	<input type="checkbox"/> Duals	<input type="checkbox"/> Single (default)		
Lift Axle:	<input type="checkbox"/> Axle 1	<input type="checkbox"/> Axle 2	<input type="checkbox"/> Axle 3	
Suspension Type:	<input type="checkbox"/> Air Suspension		<input type="checkbox"/> Mechanical Suspension	
Air Suspension	Make:	Model #:	Air Bag #:	
Air Suspension Design	<input type="checkbox"/> Single Circuit		<input type="checkbox"/> Dual Circuit	
Air Bag Pressure Data	Payload Empty (psi)		Fully Loaded (psi)	
Mechanical Suspension	Make:	Model #:	Provide Deflection Curve	
Brake Type	<input type="checkbox"/> Disc Brakes		<input type="checkbox"/> Drum Brakes	

BENDIX® TRSP® (TRAILER ROLL STABILITY PROGRAM) DATA SHEET

Bendix® TABS-6™ Advanced Module Installation (90° and 270° apply to TABS-6 Advanced Only)

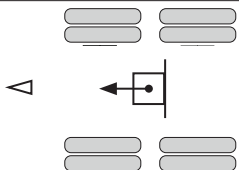
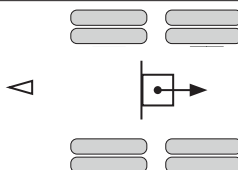
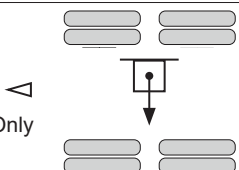
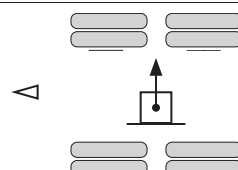
Orientation:	<input type="checkbox"/> 0° - Forward (Top View) 	<input type="checkbox"/> 180° - Rearward (Top View) 
	<input type="checkbox"/> 90° - "Road-Side" (Top View) 2S/1M TABS-6 Advanced Only 	<input type="checkbox"/> 270° - "Curb-Side" (Top View) 2S/1M TABS-6 Advanced Only 
Mounting Position:	<input type="checkbox"/> Within ± 2 in. from the centerline of the trailer (default)	More than 2 in., offset (in): <input type="checkbox"/> Left "Road-Side" <input type="checkbox"/> Right "Curb-Side"

Bendix Recommended Part Number: _____ ECU Configuration Programming Required?

Specific Instructions

BENDIX® TABS-6™ ADVANCED TRAILER MODULE INSTALLATION GUIDELINES

It is the responsibility of the trailer manufacturer to inspect all trailer Antilock Braking System (ABS) components prior to installation on the vehicle for any external damage, such as cracked valve ports, electronic housings, etc. Any components found to be damaged shall not be installed on the vehicle and must be replaced.

The TABS-6 Advanced Module is designed to meet FMVSS 121 timing requirements when installed per Bendix recommended installation guidelines and/or Bendix system drawings:

- FMVSS 121 timing compliance is the responsibility of the towed vehicle manufacturer.
- As a minimum, 5/8-in. tube size should be considered for the supply port, when frame-mounting the TABS-6 Advanced Module.

The TABS-6 Advanced Module shall be mounted with the followings considerations:

- Within ± 40 in. of the center of the axle(s) for proper balanced brake applications.
- With exhaust port facing downward and unobstructed with significant free space below (> 1 in.).
- Within ± 2 in. from the centerline of the trailer (default):
 - With the Bendix® ACom® PRO™ Diagnostic Software, a left/right offset greater than ± 2 in. can be programmed in the Electronic Control Unit (ECU).
- Yaw angle shall be $\pm 10^\circ$ as measured from the centerline of the trailer.
- Pitch angle shall be $\pm 10^\circ$ as measured from a flat horizontal plane.
- Roll angle shall be within $\pm 5^\circ$ as measured from a flat horizontal plane.

Yaw Angle

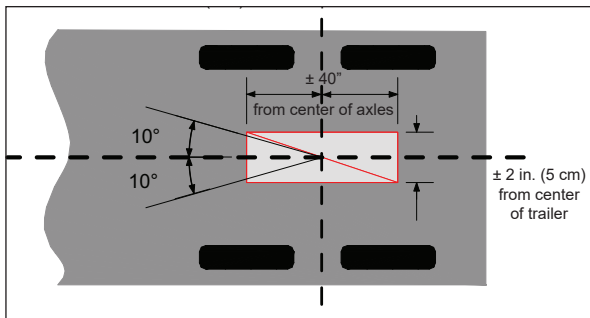

Roll Angle

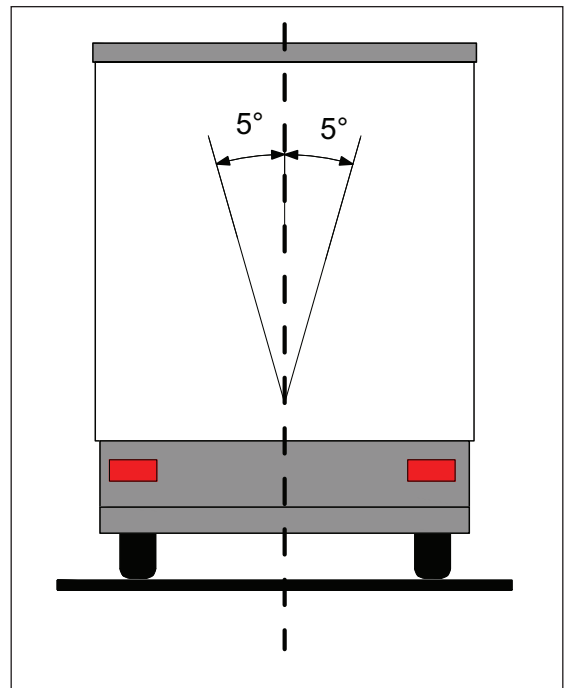

Pitch Angle

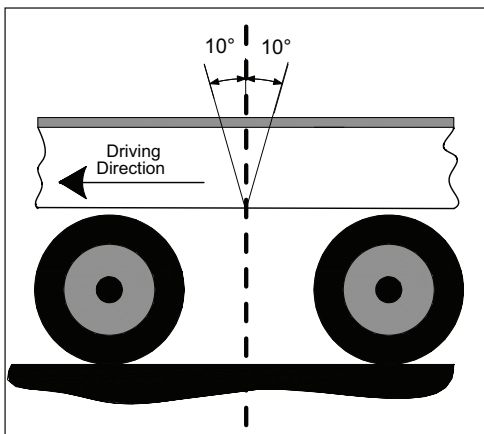

Failure to properly install the TABS-6 Advanced Trailer Module and other components can result in impaired ABS and TRSP system functions, which can result in a collision or rollover, causing property damage, serious injuries, or death. Be sure to read, understand, and follow all recommendations and guidelines carefully.

BENDIX® TABS-6™ ADVANCED TRAILER ECBS MODULE INSTALLATION GUIDELINES

For consideration during installation of the TABS-6 Advanced Module, the Wheel Speed Sensors (WSS) follow the orientation of the module as shown below:

- It is necessary to fix the WSS to the orientation of the internal lateral acceleration in the Electronic Control Unit (ECU) for plausibility checks between the sensors.
- If the WSS location does not match the orientation of the module, a fault will be generated and the Antilock Braking System (ABS) indicator lamp will be illuminated.

TABS Advanced (2S/1M – Axle)

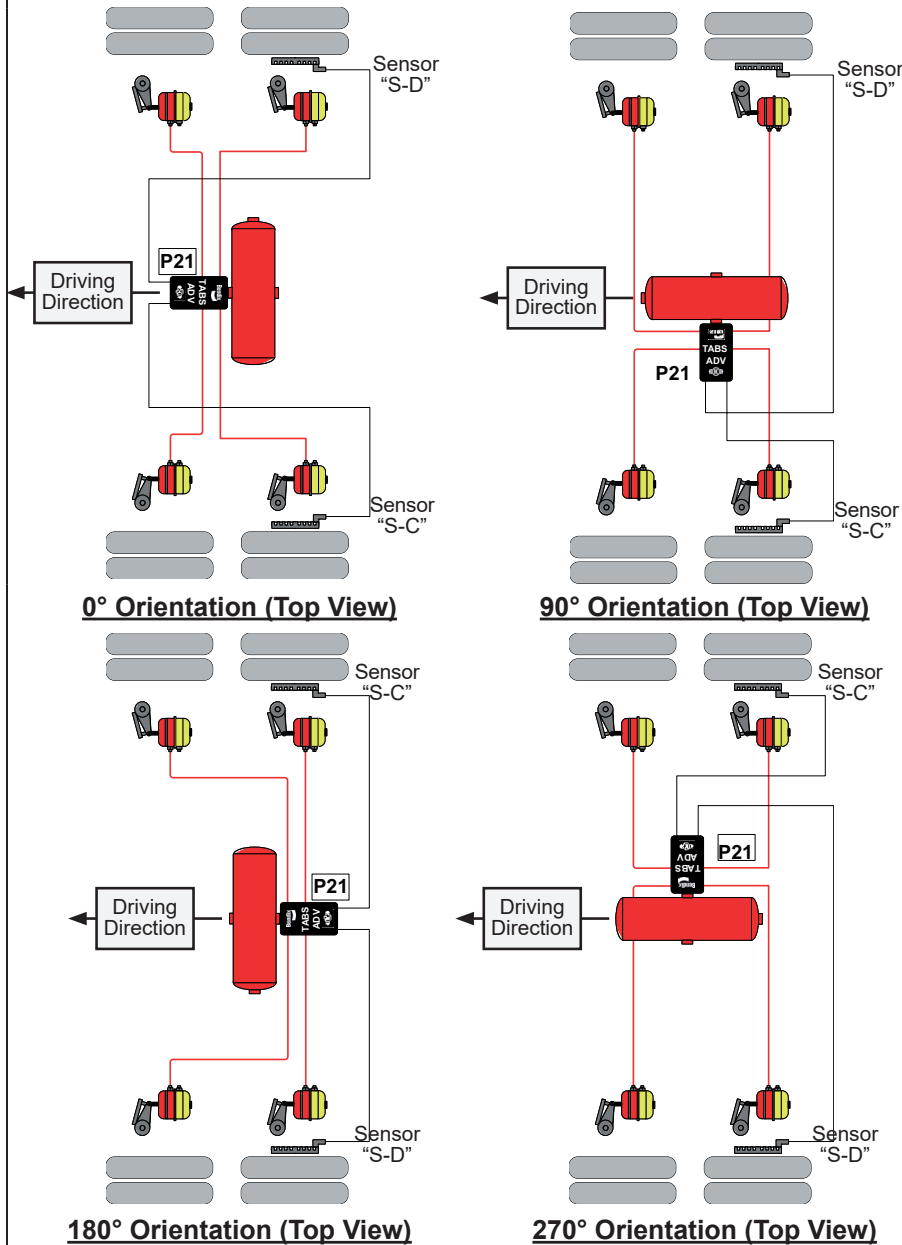

TABS-6 Advanced Multi-Channel (4S/2M – Side)

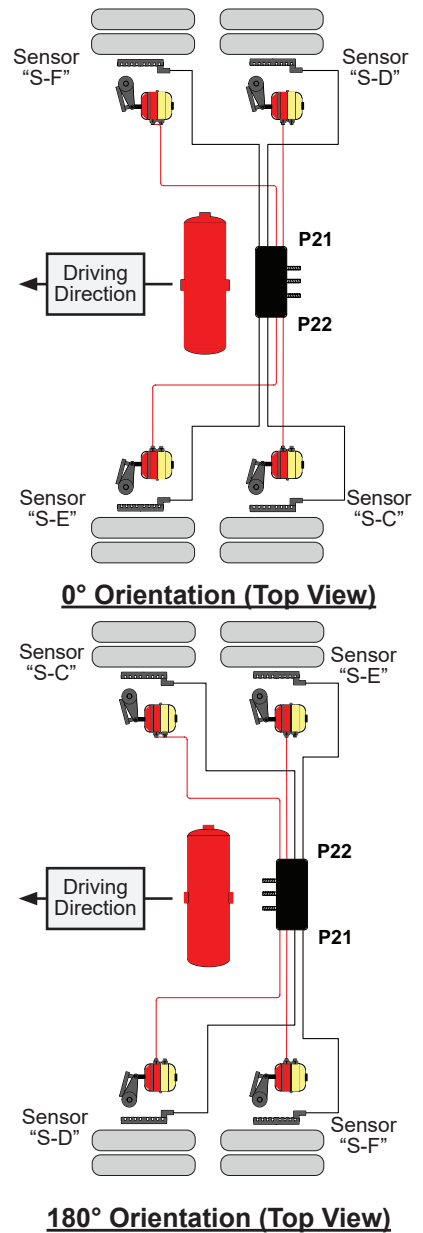

NOTE: WSS axle location can vary depending on installation