

Installation Instructions



BENDIX® ADB22X™ AIR DISC BRAKE RECALL REPAIR KIT

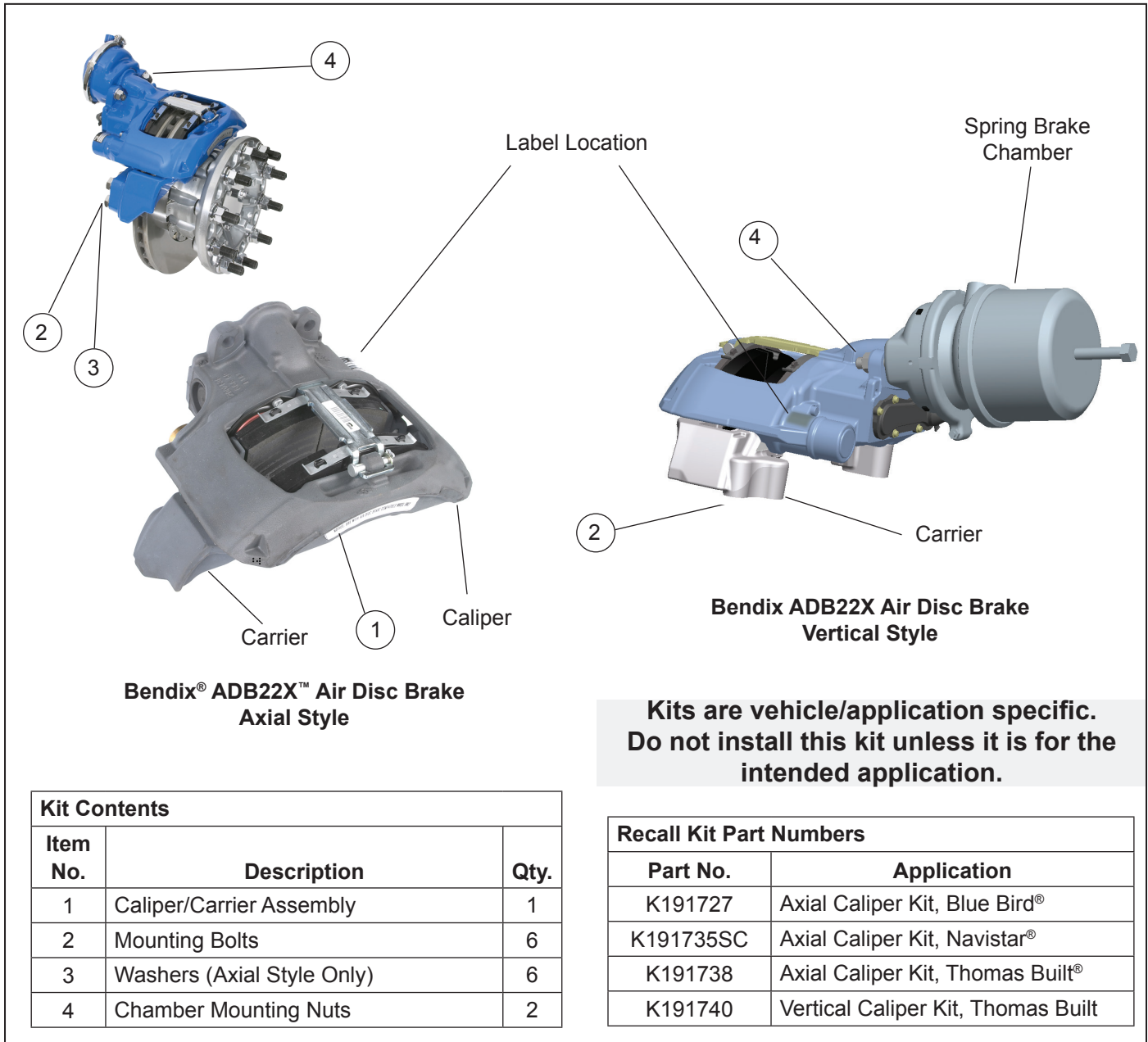

Figure 1 – Bendix® ADB22X™ Air Disc Brake Recall Repair Kit

GENERAL

This instruction sheet is intended to provide the necessary information to service the Bendix® ADB22X™ Air Disc Brake caliper/carrier assembly in connection with recall campaign number 19E030. This campaign applies only to ADB22X brake assemblies that were manufactured between January 01, 2009 and November 27, 2018, inclusive and

are installed on the left (driver's side) rear axle of a school bus. This kit contains the components shown in Figure 1. All of the kit contents must be used for the installation. Do not reuse the removed hardware (Items 2 through 4).

GENERAL SAFETY GUIDELINES



WARNING! PLEASE READ AND FOLLOW THESE INSTRUCTIONS

TO AVOID PERSONAL INJURY OR DEATH:

When working on or around a vehicle, the following guidelines should be observed **AT ALL TIMES**:

- ▲ Park the vehicle on a level surface, apply the parking brakes and always block the wheels. Always wear personal protection equipment.
- ▲ Stop the engine and remove the ignition key when working under or around the vehicle. When working in the engine compartment, the engine should be shut off and the ignition key should be removed. Where circumstances require that the engine be in operation, **EXTREME CAUTION** should be used to prevent personal injury resulting from contact with moving, rotating, leaking, heated or electrically-charged components.
- ▲ Do not attempt to install, remove, disassemble or assemble a component until you have read, and thoroughly understand, the recommended procedures. Use only the proper tools and observe all precautions pertaining to use of those tools.
- ▲ If the work is being performed on the vehicle's air brake system, or any auxiliary pressurized air systems, make certain to drain the air pressure from all reservoirs before beginning **ANY** work on the vehicle. If the vehicle is equipped with a Bendix® AD-IS® air dryer system, a Bendix® DRM™ dryer reservoir module, or a Bendix® AD-9si® air dryer, be sure to drain the purge reservoir.
- ▲ Following the vehicle manufacturer's recommended procedures, deactivate the electrical system in a manner that safely removes all electrical power from the vehicle.
- ▲ Never exceed manufacturer's recommended pressures.
- ▲ Never connect or disconnect a hose or line containing pressure; it may whip and/or cause hazardous airborne dust and dirt particles. Wear eye protection. Slowly open connections with care, and verify that no pressure is present. Never remove a component or plug unless you are certain all system pressure has been depleted.
- ▲ Use only genuine Bendix® brand replacement parts, components and kits. Replacement hardware, tubing, hose, fittings, wiring, etc. must be of equivalent size, type and strength as original equipment and be designed specifically for such applications and systems.
- ▲ Components with stripped threads or damaged parts should be replaced rather than repaired. Do not attempt repairs requiring machining or welding unless specifically stated and approved by the vehicle and component manufacturer.
- ▲ Prior to returning the vehicle to service, make certain all components and systems are restored to their proper operating condition.
- ▲ For vehicles with Automatic Traction Control (ATC), the ATC function must be disabled (ATC indicator lamp should be ON) prior to performing any vehicle maintenance where one or more wheels on a drive axle are lifted off the ground and moving.
- ▲ The power **MUST** be temporarily disconnected from the radar sensor whenever any tests **USING A DYNAMOMETER** are conducted on a vehicle equipped with a Bendix® Wingman® system.
- ▲ You should consult the vehicle manufacturer's operating and service manuals, and any related literature, in conjunction with the Guidelines above.



WARNING: Not all wheels and valve stems are compatible with Bendix® Air Disc Brakes. Use only wheels and valve stems approved by the vehicle manufacturer to avoid the risk of valve stem shear and other compatibility issues.



WARNING: AVOID CREATING DUST. POSSIBLE CANCER AND LUNG DISEASE HAZARD.

While Bendix Spicer Foundation Brake LLC does not offer asbestos brake linings, the long-term effects of some non-asbestos fibers have not been determined. Current Occupational Safety and Health Administration (OSHA) Regulations cover exposure levels to some components of non-asbestos linings, but not all. The following precautions must be used when handling these materials.

Avoid creating dust. Compressed air or dry brushing must never be used for cleaning brake assemblies or the work area.

- ▲ Bendix recommends that workers doing brake work must take steps to minimize exposure to airborne brake lining particles. Proper procedures to reduce exposure include working in a well-ventilated area, segregation of areas where brake work is done, use of local filtered ventilation systems or use of enclosed cells with filtered vacuums. Respirators approved by the Mine Safety and Health Administration (MSHA) or National Institute for Occupational Safety and Health (NIOSH) should be worn at all times during brake servicing.
- ▲ Workers must wash before eating, drinking or smoking; shower after working, and should not wear work clothes home. Work clothes should be vacuumed and laundered separately without shaking.
- ▲ OSHA & EPA Regulations regarding testing, disposal of waste, and methods of reducing exposure for asbestos are set forth in 29 & 40 Code of Federal Regulations §1910.1001 & 61.150, respectively. These Regulations provide valuable information which can be utilized to reduce exposure to airborne particles.
- ▲ Safety Data Sheets on this product, as required by OSHA, are available from Bendix. Call 1-800-247-2725 and speak to the Tech Team or e-mail techteam@bendix.com.

VEHICLE PREPARATION

1. Follow the General Safety Guidelines included on this page. Park the vehicle (by other means than the foundation brakes) on level ground and chock the wheels.
2. Drain all reservoirs to 0 psi (0 kPa).
3. Clean the exterior of the Bendix® ADB22X™ Air Disc Brake assembly.

Interpreting the Serialized Production Code

The serialized production code is on the identification label that is located on the caliper casting in the fixed pin area. See Figure 1 on page 1. Locate the serialized production code – removing the paint coating, if necessary – to read the code. Disregard the Work Team Number, Shift of Manufacture, Manufacturing Plant, Production Line, and Shift Number codes shown in the gray boxes below. The portion of the serialized production code that determines the date of manufacture is highlighted and can be interpreted as follows:

- The first field is the month (A=January, B=February, etc. – excluding the letter I – so that J=September, and so on);
- The next two fields are the day of the month (e.g. 01=1st); and
- The next two fields are the year (e.g. 18=2018).

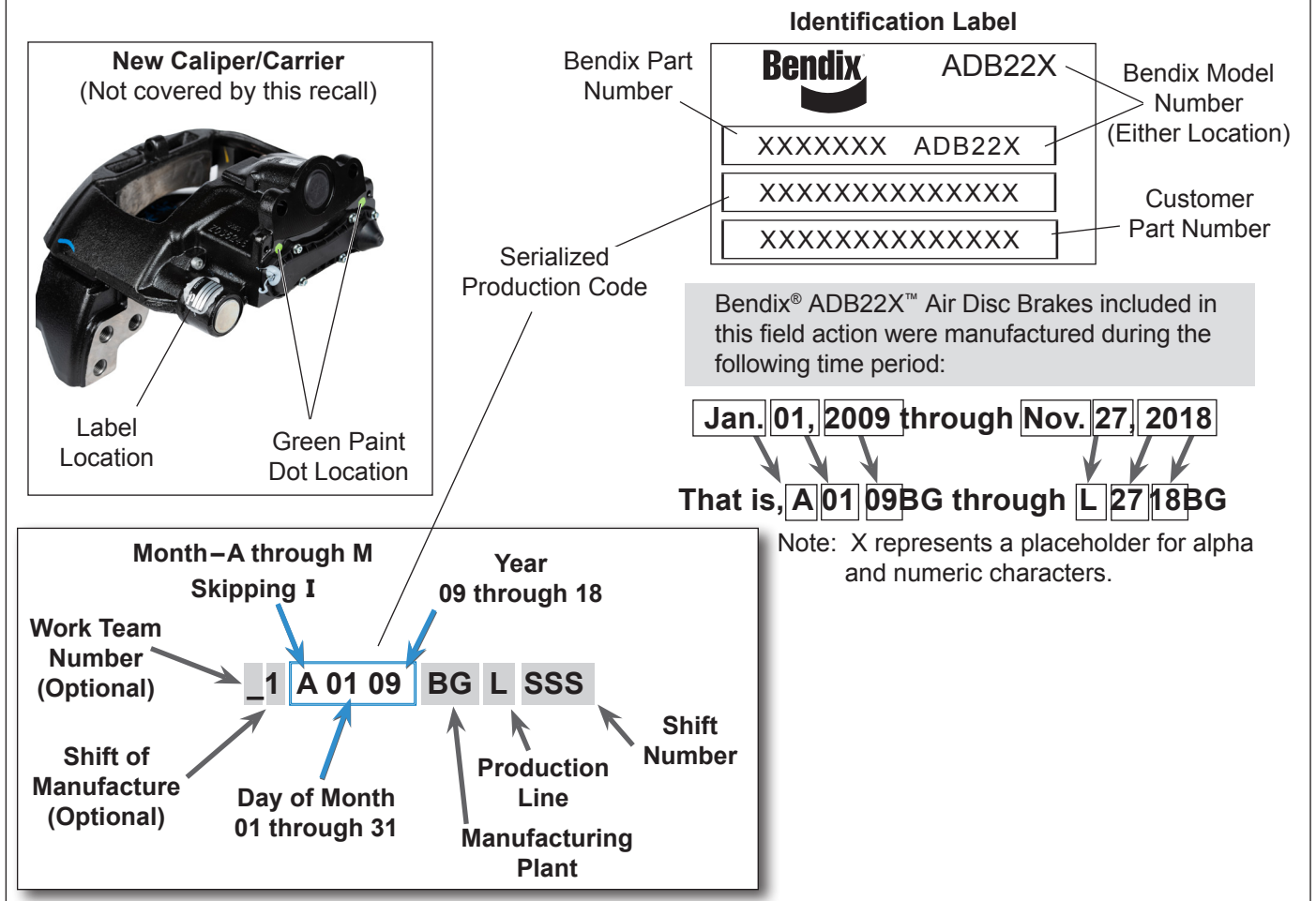

Figure 2 – Bendix® ADB22X™ Air Disc Brake Identification Label

4. Verify the caliper/carrier is a part of the recall campaign by checking for a **green paint dot** in the location shown in Figure 2. This green dot indicates that the Bendix® ADB22X™ Air Disc Brake caliper/carrier was already replaced as a part of the recall campaign.
5. If a green dot is not visible, look for the part number label on the caliper as shown in Figure 2. This may require the removal of paint and road debris to clearly identify the brake assembly. Go to the *Identification Label* section for interpretation of the identification label.

IDENTIFICATION LABEL

The identification label contains the part number, brake model, serialized production code, and, in some cases a customer part number. See Figure 2 for the interpretation of the identification label.

1. Verify the model number on the tag is ADB22X. If the model is not ADB22X this brake assembly is not affected by this recall. Note that the Bendix® ADB22X™-LT and ADB22X™-V Air Disc Brakes are not a part of this recall.
2. Verify the date of manufacture is between Jan. 1, 2009 and Nov. 27, 2018, inclusive. If the date of manufacture is not within this time frame the brake assembly is not covered by this recall.

DISASSEMBLY

CAUTION: Follow all safe maintenance practices, including those listed on page 2 of this document. Park the vehicle (by other means than the foundation brakes) on level ground and chock the wheels.

CAUTION: When using a hoist to support the air disc brake, do not attempt to use the pad retainer bar as a bracing point. It is not designed to support the weight of the brake. Instead, use a brace (or chain) wrapped around the entire brake to attach the hoist.

SPRING OR SERVICE BRAKE CAGING & REMOVAL

Use the spring brake manufacturer's recommended safety practices in all cases.

Some spring brake and vehicle manufacturers permit caging the spring brake while the spring brake is engaged.

BENDIX® BRAND PISTON-STYLE ACTUATORS

1. With the vehicle on a level surface and the wheels properly chocked, apply air to release the spring brakes (parking brakes) by using the dash-mounted air control valve. Back out the release bolt (See *Figure 3*, arrow "A"), using a maximum torque of 26 ft-lbs (35 Nm) to cage the air released spring force on the pushrod.

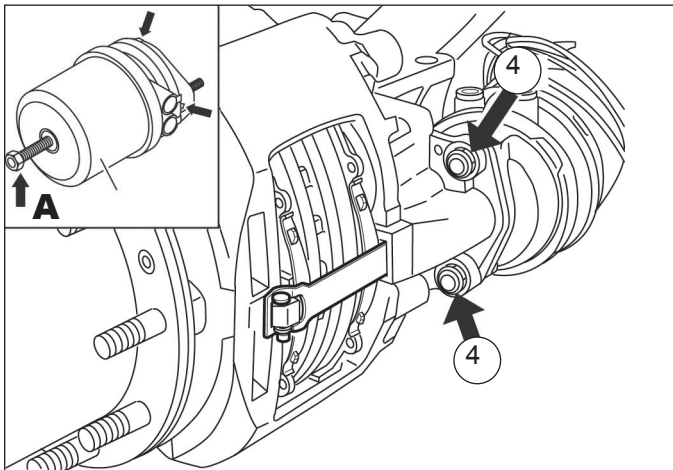

Figure 3 – Actuator Spring Caging and Removal

2. Exhaust the air from the spring brake chambers by using the dash-mounted air control valve. While supporting the chamber in position, remove and discard the brake chamber mounting nuts (Item 4) (See *Figure 3*). Mark the orientation of the chamber to the mounting bracket for remounting. Remove the spring brake chamber. If it becomes necessary to disconnect the air hoses to the chamber, with all air pressure drained from the system, mark the hoses for reconnection and then disconnect the hoses from the chamber.

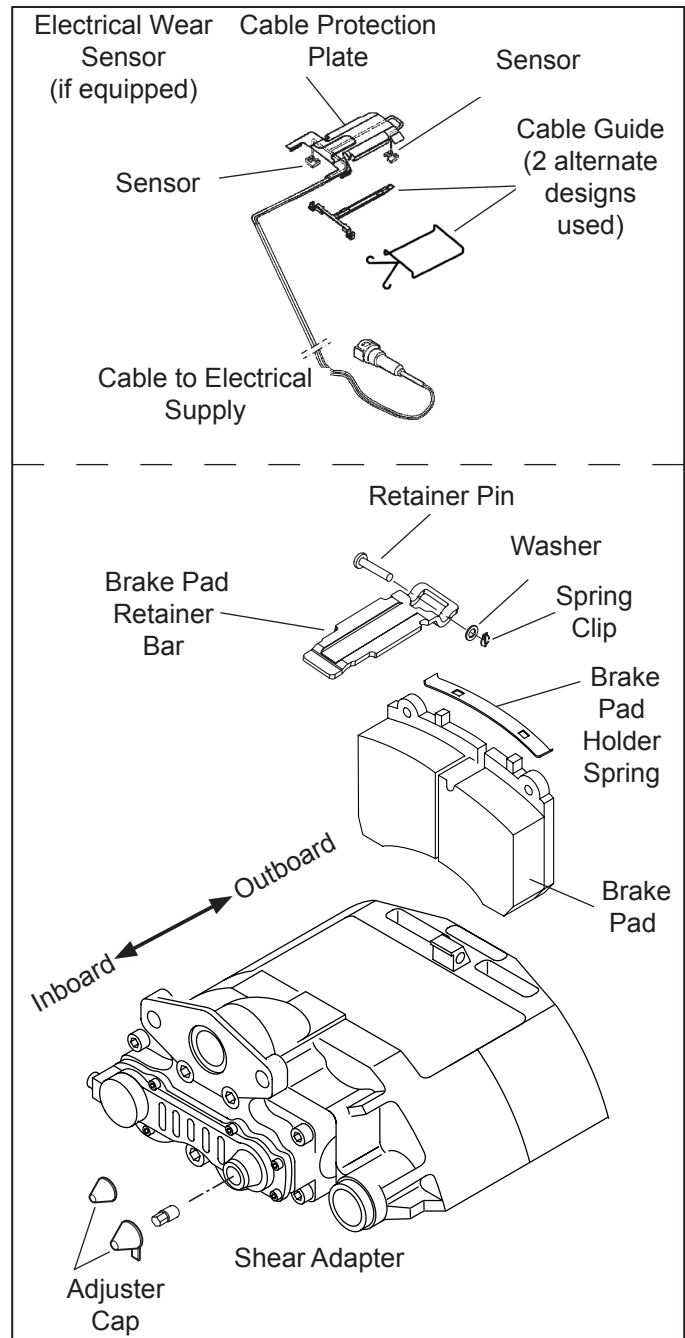

Figure 4 – Pad Replacement

BRAKE PAD REMOVAL

1. If the air disc brake is equipped with an electronic wear sensor indicator (See *top of Figure 4*), remove and retain the cable protection plate and its mounting hardware. Note the position of the sensors in the brake pad channels, and carefully remove them. In most cases it is not necessary to release the cable connector in order to move the sensors away from the pad installation work area. Inspect the wear sensors – replace if damaged or abraded.
2. (See *Figure 4*). While pressing down against the brake pad retaining bar, remove the spring clip, washer, and retainer pin and brake pad retainer bar.
3. Remove and retain the pad shield (if equipped). (See *Figure 5*).

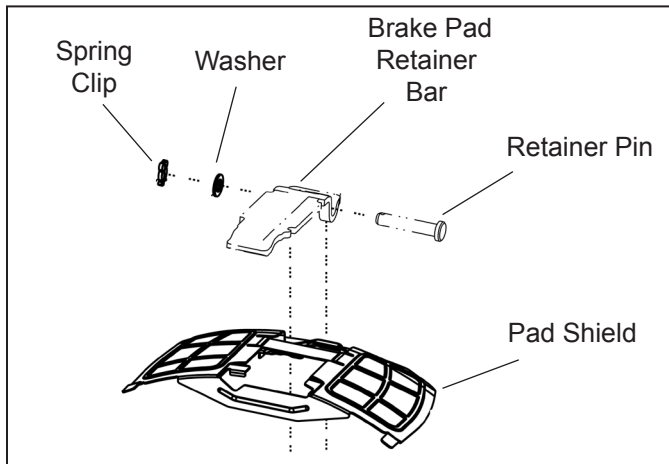

Figure 5 – Pad Shield

4. Follow the steps in the *Adjuster Mechanism* section for backing-off the adjuster mechanism. Slide the caliper inboard then outboard to permit easy removal of the brake pads. Remove and retain the brake pads.

ADJUSTER MECHANISM

1. With the spring brake released (or caged), remove the adjuster cap using the tab, taking care not to move the shear adapter. Note: One of two styles of adjuster cap (stamped metal or plastic adjuster cap) may be used.

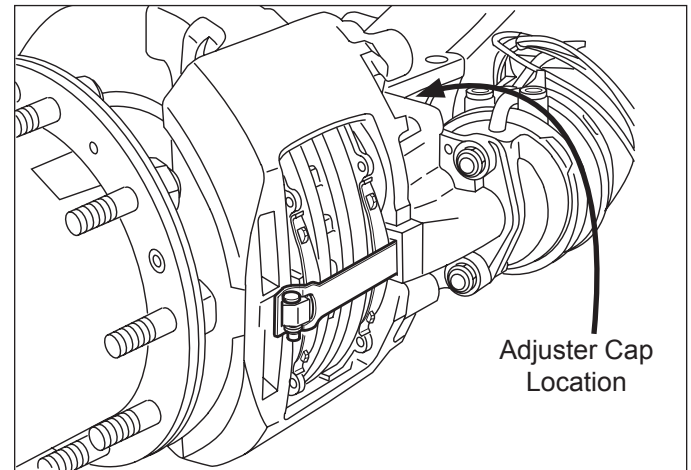
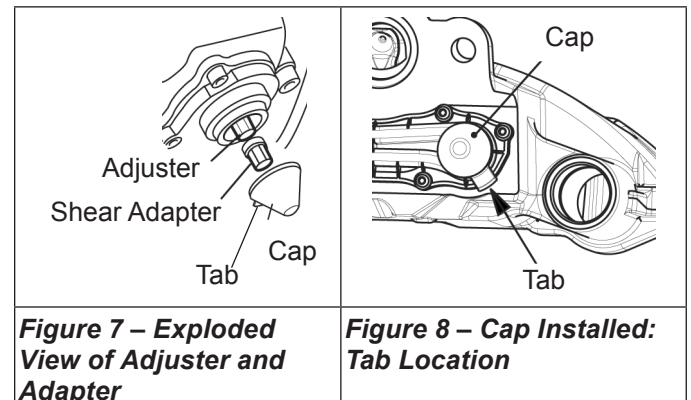

Figure 6 – Adjuster Cap Location



2. For illustration purposes, the exploded view (*Figure 7*) shows the adjuster and shear adapter separated. When using the adjuster mechanism, always have the shear adapter installed on the adjuster.
3. Using a 10mm six-point box wrench, turn the shear adapter counterclockwise and listen for the sound of three clicks as the mechanism backs-off (increases) the running clearance. Note: Do not use an open-ended wrench as this may damage the adapter.

CAUTION:

Never turn the adjuster without the shear adapter installed. The shear adapter is a safety feature and is designed to prevent excessive torque from being applied to the adjuster. The shear adapter will fail (by breaking) if too much torque is applied.

CALIPER/CARRIER DISASSEMBLY

CAUTION: Follow all safe maintenance practices, including those listed on page 2 of this document. Park the vehicle (by other means than the foundation brakes) on level ground and chock the wheels.

CAUTION: When using a hoist to support the air disc brake, do not attempt to use the pad retainer bar as a bracing point. It is not designed to support the weight of the brake. Instead, use a brace (or chain) wrapped around the entire brake to attach the hoist.

Note that this instruction sheet covers both the vertical and axial mounting bolt styles. Go to the appropriate section for your application.

DISASSEMBLY - VERTICAL MOUNTING BOLT STYLE

1. (See Figure 9). Supporting the air disc brake by necessary means, remove and discard the six mounting bolts (Item 2). Lift the caliper up off the anchor plate. (See Figure 9).
2. The vertical bolt assembly includes an alignment bushing. **This bushing must be saved for reuse during reassembly of the brake.** The bushing mounts in the torque plate and maintains the correct alignment of the brake assembly relative to the rotor.
3. If the brake assembly does not separate from the anchor plate it may be helpful to install an M16X2.0 screw longer than 120 mm at the bushing locations and tap the end of the bolt with a hammer to free the brake assembly. Remove the caliper/carrier assembly.

DISASSEMBLY - AXIAL MOUNTING BOLT STYLE

1. (See Figure 10). Supporting the air disc brake by necessary means, remove and discard the six bolts (Item 2) and washers (Item 3) attaching the brake to the anchor plate and remove the caliper/carrier assembly from the vehicle.

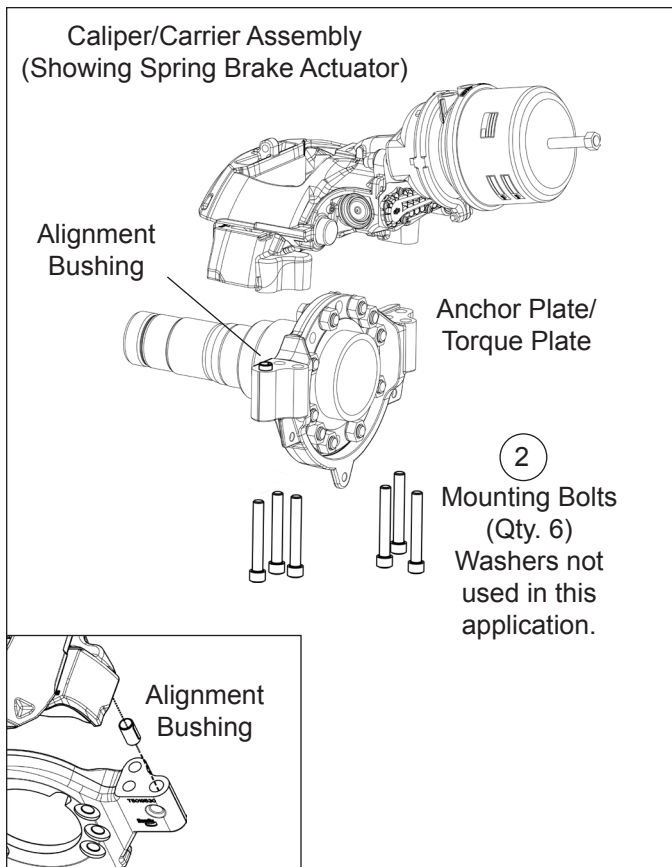

Figure 9 – Vertical Mount Caliper/Carrier

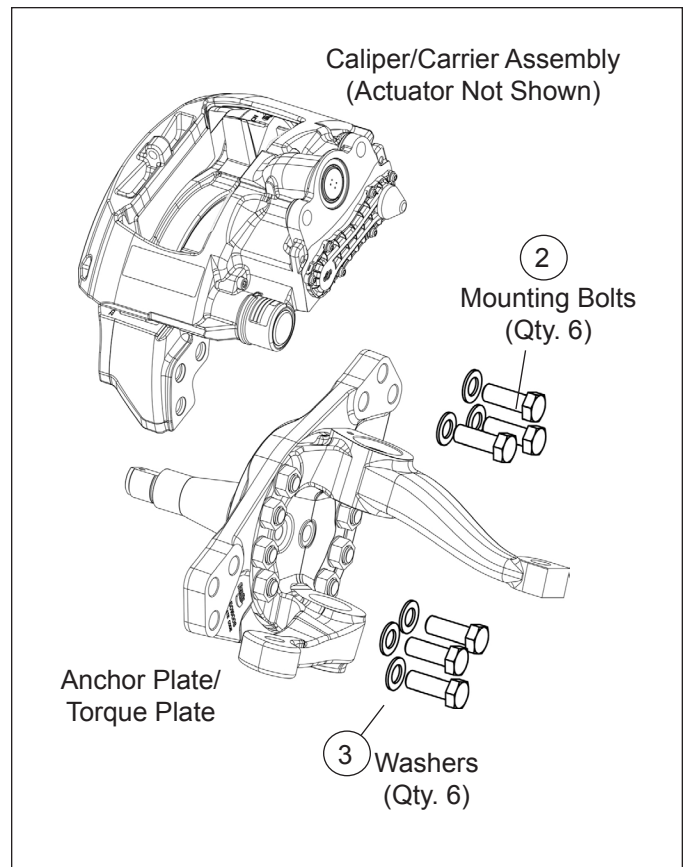

Figure 10 – Axial Mount Caliper/Carrier

CALIPER/CARRIER REINSTALLATION (BOTH STYLES)

1. Supporting the air disc brake by necessary means, attach the brake to the anchor plate using six bolts (Item 2) and, if included, washers (Item 3). Do not reuse the removed bolts and washers. Torque to the values shown in Table 1.

SPRING OR SERVICE BRAKE REINSTALLATION

CAUTION: Do not use spring brake chambers with seals that have a thickness less than 0.12 in. (3 mm). Use only actuators which are recommended by the vehicle manufacturer.

1. Ensure the spring brake chamber mounting area is clean and free of any debris. (See *B* in Figure 11).

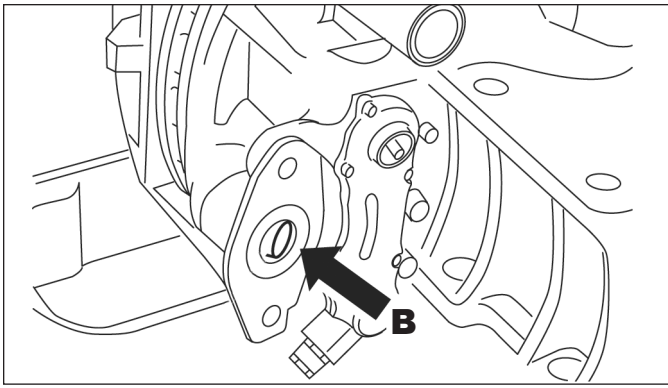

Figure 11 – Spring Brake Installation

2. Position the spring brake chamber in the same orientation it was removed. Secure the chamber with the spring brake chamber mounting nuts (Item 4). See Figure 3. Alternately tighten both the nuts step-by-step up to a final torque of 133 ± 7 ft-lbs (180 ± 10 Nm). **Do not reuse the nuts that were removed during the disassembly.**
3. If the air hoses were disconnected, reconnect the air hoses as marked and be sure that each hose is not twisted or in contact with moving vehicle components. The air hose routing must allow for full caliper travel. Note that for spring brake service chambers the ports are indicated by: “11” Service Brake Port and “12” Spring Brake Port. (See Figure 12).

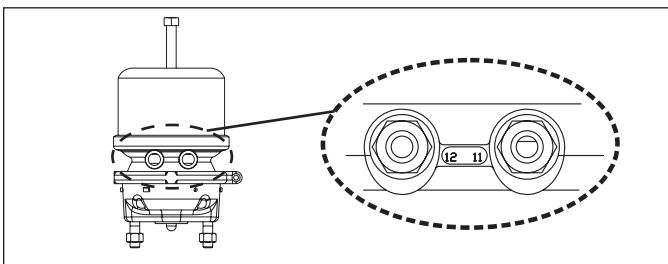

Figure 12 – Port Designations

Note: If a new spring brake chamber is being installed, note that the chamber may contain drain plugs installed around the perimeter of the body. If drain plugs are present, after installation, remove whichever plug is at the lowest position. The selected drain hole must be aligned downwards (or within $\pm 30^\circ$) when installed on the vehicle.

BRAKE PAD REPLACEMENT

Before installing the brake pads, use the adjuster to fully retract the tappets to provide adequate clearance.

Clean the surfaces that will come in contact with the brake pad.

Caution: When installing pads and retaining springs, where appropriate, use heavy duty gloves and always keep fingers away from potential pinch hazard areas.

1. Install the brake pad retaining springs onto the brake pads by inserting one end of the spring onto the lug at the top of the brake pad (See Figure 13). Carefully apply enough force to permit the second lug to fully engage, taking care to keep fingers etc. away from the spring as it seats.

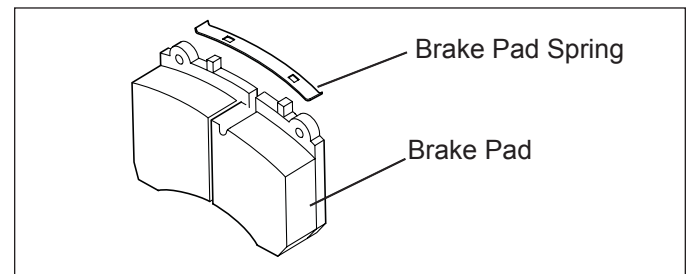

Figure 13 – Pad Retaining Spring Installation

2. Pull the caliper fully outward and install the outboard pad. Move the caliper fully inward and install the inboard pad.
3. To reinstall wear indicators (if used): Insert the wear sensors into position in the new brake pads. Route the sensor cable through the cable protection plate channel and secure the plate with the mounting hardware retained at disassembly. (See the *Brake Pad Removal* section.)
4. Push the pad retainer bar into the groove of the caliper. Press down on the pad retainer bar, and insert the pad retainer pin, with the pin pointing downwards, where possible. Install the washer and then the spring clip. (See Figure 4).
5. Using a 10 mm, six-point box wrench, turn the shear adapter clockwise until the pads contact the rotor. Note: Do not use an open-ended wrench as this may damage the adapter. (See Figure 14).

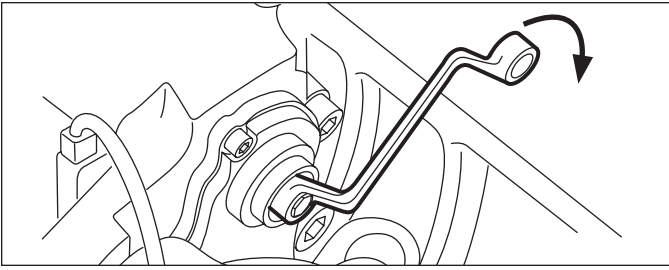

Figure 14 – Clockwise Rotation

If the shear adapter fails, you may attempt a second time with a new (unused) shear adapter.

Note: Always double-check that the spring brake is released (where applicable) if a shear adapter fails; if this step was missed, the shear adapter will break off, and it may appear that the caliper is seized.

In cases where a second failure of the shear adapter confirms that the adjustment mechanism is seized, the caliper must be replaced.

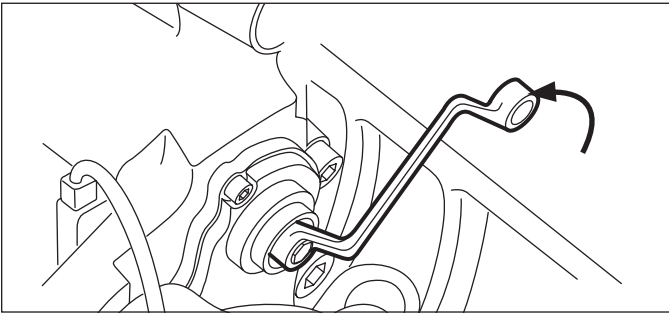

Figure 15 – Counterclockwise rotation

6. Using the same tool, turn the shear adapter counterclockwise and listen for the sound of 3 clicks as the mechanism backs-off (increases) the running clearance. (See Figure 15).
7. Replace the adjuster cap.
8. Apply and release the brakes. The hub should turn easily by hand after applying and releasing the brake.
9. Recheck the running clearance. Readjust if necessary.
10. Reinstall the wheel, following the vehicle manual instructions.



The brake pads and rotor must be maintained within the recommended wear limits. Failure to monitor wear and replace the brake pads and rotor when required may result in diminished brake performance.

Important: If replacing the pads with new pads Bendix strongly recommends that whenever brake pads are replaced, the complete axle set be replaced together to maintain optimal braking, Use only pads which are permitted by the vehicle manufacturer, axle manufacturer, and/or disc brake manufacturer. Failure to comply with this may invalidate the vehicle manufacturer's warranty.

OPERATIONAL TEST

1. Before returning the vehicle to service, with the system pressurized, using a soap solution, check for air leakage. Minimal leakage in the area around the diaphragm is permitted (100 SCCM), and a one-inch bubble in one minute at the hose fitting is acceptable. If abnormal leakage is detected, the diaphragm must be replaced, or the fitting adjusted, respectively.

COMPLETION OF RECALL KIT INSTALLATION

After the installation of the caliper/carrier is complete, process the removed caliper/carrier per your normal core procedures.

If you have additional questions or concerns regarding this recall, contact the Bendix Tech Team at 1-800-AIR-BRAKE (1-800-247-2725), option 2.

Air Disc Brake Attachment Hardware	
Vertical Mount	Fastener & Torque*
<p>Service Actuators Shown</p> <p>Left-hand Brake Right-hand Brake</p> <p>Washers are not used on vertical-mounted ADB22X™ brake assemblies</p>	<p>Thomas Built®</p> <p>Mounting Bolts (Item 2): M16 x 2.0 x 110 mm, Class 12.9. Use the new fasteners included.</p> <p>Washer (Item 3): None used.</p> <p>Torque: Using the torque pattern below, pre-torque to between 40-50 ft-lbf [54-68 N·m], with a final torque of 229 ft-lbf [310 N·m].</p>
Left-Hand Brake Torque* Pattern (Viewed from Below)	Right-Hand Brake Torque* Pattern (Viewed from Below)
<p>Brake's short (floating Pin) is this side</p> <p>(view from below)</p> <p>Sheer sleeve above, in this location Shelf above, in this location</p>	<p>Brake's short (floating pin) is this side</p> <p>(view from below)</p> <p>Shelf above, in this location Sheer sleeve above, in this location</p>
Axial Mount	Fastener & Torque*
<p>Caliper/Carrier Assembly (showing service actuator)</p> <p>Anchor Plate/ Torque Plate</p>	<p>Blue Bird®</p> <p>Mounting Bolts (Item 2): M20 x 50 mm Class 10.9.</p> <p>Torque: Pre-torque to 20-60 ft-lbf [27-81 N·m], with a final torque of 350-400 ft-lbf [475-542 N·m].</p> <p>Navistar®</p> <p>Mounting Bolts (Item 2): M20 x 60 mm Class 10.9.</p> <p>Torque: Pre-torque to 20-60 ft-lbf [27-81 N·m], with a final torque of 350-400 ft-lbf [475-542 N·m].</p> <p>Thomas Built</p> <p>Mounting Bolts (Item 2): M20 x 60 mm Class 10.9.</p> <p>Torque: Pre-torque to 20-60 ft-lbf [27-81 N·m], with a final torque of 375 ft-lbf [510 N·m].</p> <p>Washer (Item 3): Use the new mounting bolts and washers included.</p>
	Torque* Pattern
	<p>Any cross-pattern, see the example below:</p> <p>① ⑤ ⑥ ④</p> <p>③ ②</p>

*Use the new fasteners included in the kit when installing the air disc brake caliper. Ensure that the brake caliper guide pins slide freely once the final torque has been achieved on all fasteners. Refer to the OE maintenance manuals for vehicle specific installation recommendations.

Table 1 – Torque Plate Fasteners and Torque Recommendations (see manufacturer's recommendations)

Knowledge Dock™
Please select media to browse.

Blog Video Blog Tech Tips Podcast

Trucking moves fast. Move faster.
Knowledge Dock™
• BLOGS • PODCASTS • VIDEOS • 24/7/365
[knowledge-dock.com]

Log-on and Learn from the Best
On-line training that's available when you are –24/7/365.
Visit brake-school.com.

