

# Installation Instructions

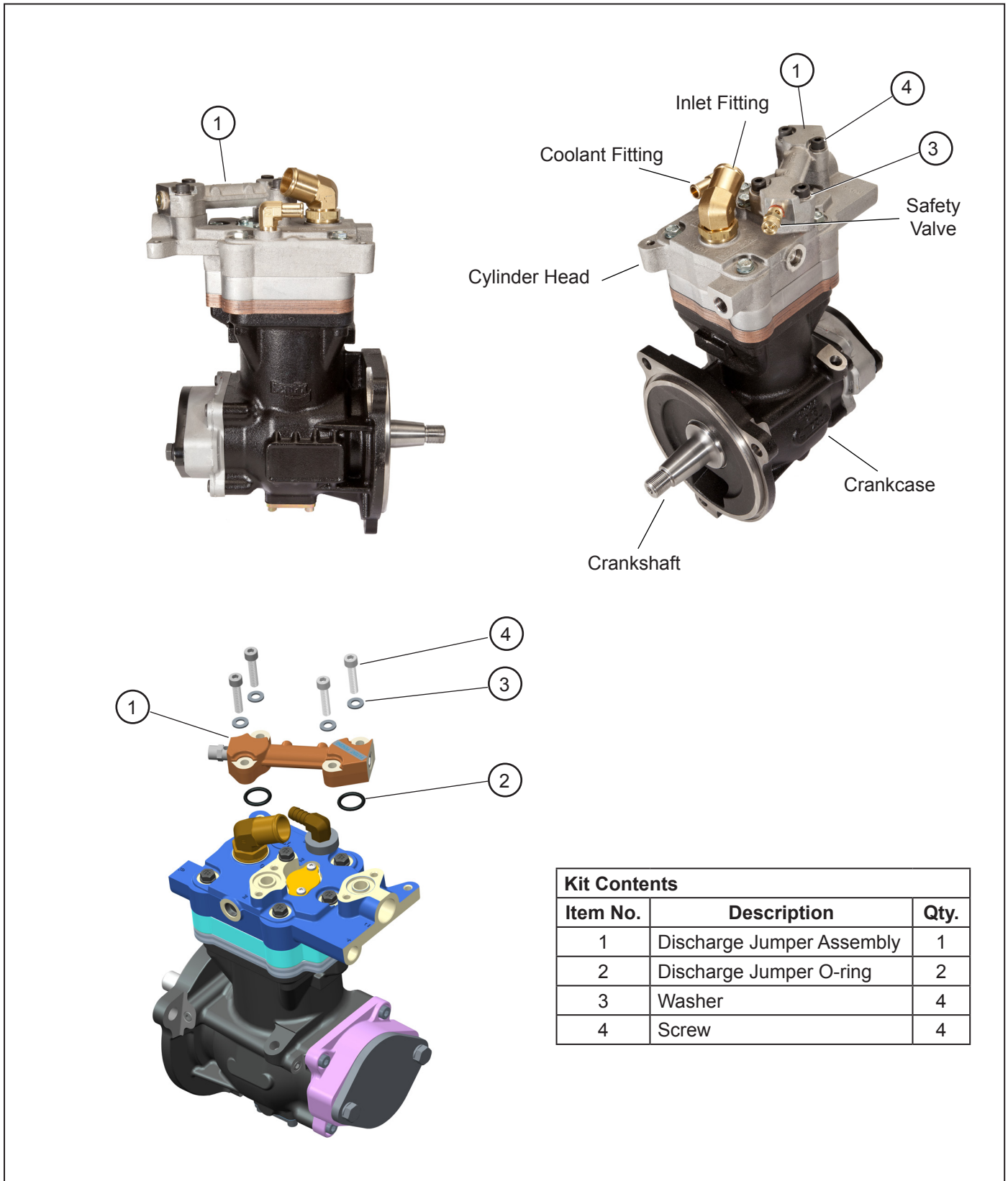

## BENDIX® SNA-01™ COMPRESSOR DISCHARGE JUMPER KIT



Kit Contents		
Item No.	Description	Qty.
1	Discharge Jumper Assembly	1
2	Discharge Jumper O-ring	2
3	Washer	4
4	Screw	4

Figure 1 – Bendix® SNA-01™ Compressor Discharge Jumper Assembly Kit



## GENERAL SAFETY GUIDELINES

**WARNING! PLEASE READ AND FOLLOW THESE INSTRUCTIONS**

**TO AVOID PERSONAL INJURY OR DEATH:**

**When working on or around a vehicle, the following guidelines should be observed AT ALL TIMES:**

- ▲ Park the vehicle on a level surface, apply the parking brakes and always block the wheels. Always wear personal protection equipment.
- ▲ Stop the engine and remove the ignition key when working under or around the vehicle. When working in the engine compartment, the engine should be shut off and the ignition key should be removed. Where circumstances require that the engine be in operation, **EXTREME CAUTION** should be used to prevent personal injury resulting from contact with moving, rotating, leaking, heated or electrically-charged components.
- ▲ Do not attempt to install, remove, disassemble or assemble a component until you have read, and thoroughly understand, the recommended procedures. Use only the proper tools and observe all precautions pertaining to use of those tools.
- ▲ If the work is being performed on the vehicle's air brake system, or any auxiliary pressurized air systems, make certain to drain the air pressure from all reservoirs before beginning ANY work on the vehicle. If the vehicle is equipped with a Bendix® AD-IS® air dryer system, a Bendix® DRM™ dryer reservoir module, or a Bendix® AD-9si® air dryer, be sure to drain the purge reservoir.
- ▲ Following the vehicle manufacturer's recommended procedures, deactivate the electrical system in a manner that safely removes all electrical power from the vehicle.
- ▲ Never exceed manufacturer's recommended pressures.
- ▲ Never connect or disconnect a hose or line containing pressure; it may whip and/or cause hazardous airborne dust and dirt particles. Wear eye protection. Slowly open connections with care, and verify that no pressure is present. Never remove a component or plug unless you are certain all system pressure has been depleted.
- ▲ Use only genuine Bendix® brand replacement parts, components and kits. Replacement hardware, tubing, hose, fittings, wiring, etc. must be of equivalent size, type and strength as original equipment and be designed specifically for such applications and systems.
- ▲ Components with stripped threads or damaged parts should be replaced rather than repaired. Do not attempt repairs requiring machining or welding unless specifically stated and approved by the vehicle and component manufacturer.
- ▲ Prior to returning the vehicle to service, make certain all components and systems are restored to their proper operating condition.
- ▲ For vehicles with Automatic Traction Control (ATC), the ATC function must be disabled (ATC indicator lamp should be ON) prior to performing any vehicle maintenance where one or more wheels on a drive axle are lifted off the ground and moving.
- ▲ The power **MUST** be temporarily disconnected from the radar sensor whenever any tests **USING A DYNAMOMETER** are conducted on a vehicle equipped with a Bendix® Wingman® system.
- ▲ You should consult the vehicle manufacturer's operating and service manuals, and any related literature, in conjunction with the Guidelines above.

## GENERAL

This kit is intended to service the Bendix® SNA-01™ compressor discharge jumper. All components replaced by those contained in this kit should be discarded.

These instructions are general and are intended to be a guide. In some cases, additional preparations and precautions are necessary. In all cases, follow the instructions contained in the vehicle maintenance manual in lieu of the instructions, precautions, and procedures presented in this document.

## VEHICLE PREPARATION

### COMPRESSOR REMOVAL & DISASSEMBLY

In many instances it may not be necessary to remove the compressor from the vehicle when installing this kit. The maintenance technician must assess the installation and determine the correct course of action.

1. Block the wheels of the vehicle and drain the air pressure from all the reservoirs in the system.
2. Drain the engine cooling system and the cylinder head of the compressor. Identify and disconnect all air, water, and oil lines leading to the compressor.
3. Remove as much road dirt and grease from the exterior of the compressor as possible.
4. Remove the discharge and inlet fittings, if applicable, and note their position on the compressor to aid in reassembly.
5. Remove any supporting bracketing attached to the compressor and note their positions on the compressor to aid in reassembly.
6. Remove the front flange mounting bolts/nuts and remove the compressor from the vehicle.
7. Inspect the drive gear and associated drive parts for visible wear or damage. If the compressor drive gear is worn or damaged, the drive gear must be removed and replaced. Refer to the engine manufacturer's service manual to address the associated engine drive parts.

### PREPARATION FOR DISASSEMBLY

Remove the balance of road dirt and grease from the exterior of the compressor with a cleaning solvent. Prior to disassembly, make certain that the appropriate kit is available. *Refer to Figure 1 during the entire disassembly and assembly procedure.*

## DISCHARGE JUMPER REMOVAL

1. Loosen and remove the four washers (3) and screws (4) that secure the discharge jumper assembly (1) to the cylinder head. Remove the discharge jumper assembly and the two o-rings (2).
2. Clean the head area where the discharge jumper assembly (1) was removed.

## ASSEMBLY

General Note: All torques specified in this manual are assembly torques and typically can be expected to fall off after assembly is accomplished. Do not retorque after the initial assembly torques fall unless instructed otherwise.

## DISCHARGE JUMPER ASSEMBLY INSTALLATION (REFER TO FIGURE 2)

1. Apply a coating of silicone lubricant to the two discharge jumper o-rings (2) and o-ring grooves. Install the o-rings (2) into the two o-ring grooves on the cylinder head.
2. Position the discharge jumper assembly (1) over the cylinder head such that it lines up with the four attachment bolt holes. Refer to Figure 2 to ensure proper orientation on the cylinder head. Note: There is only one way the discharge jumper (1) can be installed on the cylinder head.
3. Install a washer (3) and screw (4) in each of the four holes on the discharge jumper assembly. Hand tighten the four screws (4) and torque in a cross pattern to 115–133 in-lbs (13–15 N•m).

## INSTALLING THE COMPRESSOR

If the compressor was not removed to facilitate the installation of this kit, go to step 3.

1. Install a new front flange o-ring on the pilot of the front flange of the compressor. Gasket sealants are not recommended. Secure the compressor on the engine and tighten the mounting bolts per the engine manufacturer's recommended torque requirements.
2. Install any supporting brackets on the compressor in the same position(s) noted and marked during removal. If a rear support bracket was on the original installation, hand tighten the bolts on both ends before torquing the bolts. *Note: It is important that the rear support bracket is flush to both surfaces before the bolts are torqued.*
3. Inspect all air, oil, and coolant lines and fittings before reconnecting them to the compressor. Make certain o-ring seals are in good or new condition, the threads are clean, and the fittings are free of corrosion. Replace as necessary.
4. Install the discharge, inlet, coolant and governor adapter fittings—if applicable—in the same position on the compressor noted and marked during disassembly. Tighten all hose clamps.
5. Before returning the vehicle to service, perform the Operation and Leakage Tests specified in this manual. Pay particular attention to all lines and hoses disconnected during the maintenance and check for air, oil, and coolant leaks at compressor connections. Also check for noisy operation.

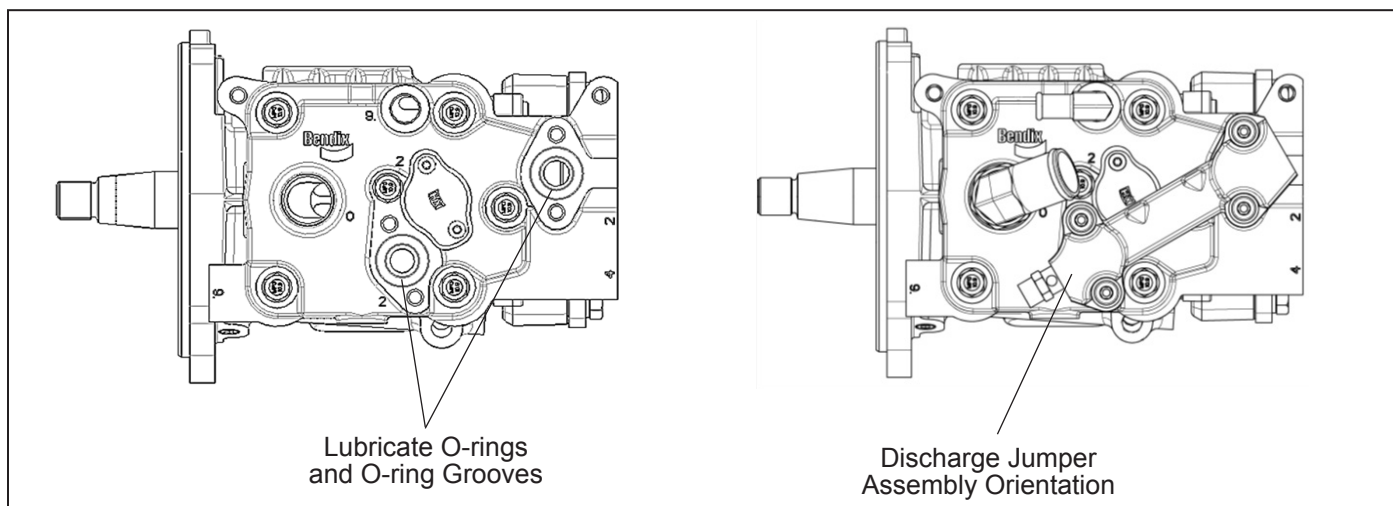

Figure 2 – Discharge Jumper Assembly

## OPERATION & LEAKAGE TESTS

1. Start the engine and note that air system steadily builds pressure.
2. With system air pressure increasing, check for cylinder head gasket air leakage. Apply a soap solution around the cylinder head. Check the gaskets between the cylinder head, cooling plate, and valve plate assembly for air leakage. No leakage is permitted. If leakage is detected, try torquing the head bolts again after draining all air pressure. Replace the compressor if replacing the head gasket has not resolved the leakage problem.
3. Allow air system pressure to build and note that the compressor unloads properly at the specified governor cut-out pressure. Repeat this test three times noting

that the compressor unloads at approximately the same pressure each time. If the compressor fails to unload by at least 150 psi system pressure, check all air lines to and from the governor. Make certain each line is clear (unobstructed) and not kinked, or leaking. Repair or replace the governor as needed. If an unloader kit was also installed, recheck installation.

4. More complete compressor performance tests are provided in the *Bendix Service Data sheet SD-01-10142*. This publication is available online at [bendix.com](http://bendix.com) or by calling 1-800-247-2725, option 5.



### Log-on and Learn from the Best

On-line training that's available when you are—24/7/365.  
Visit [www.brake-school.com](http://www.brake-school.com).