

Installation Instructions

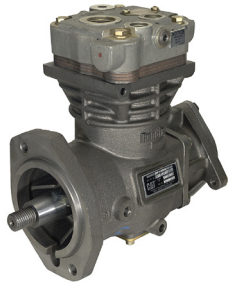

BENDIX® BA-921® AND BA-922® COMPRESSOR UNLOADER KIT



Bendix® BA-921®
Compressor

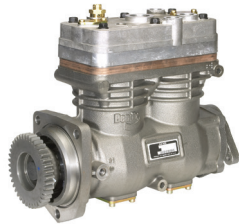

Bendix® BA-922®
Compressor

Unloader Cap
If a new cap is included in the kit, discard it and reuse the cap that was installed on the compressor being serviced.

If the compressor came with a splash shield, it should be reused.

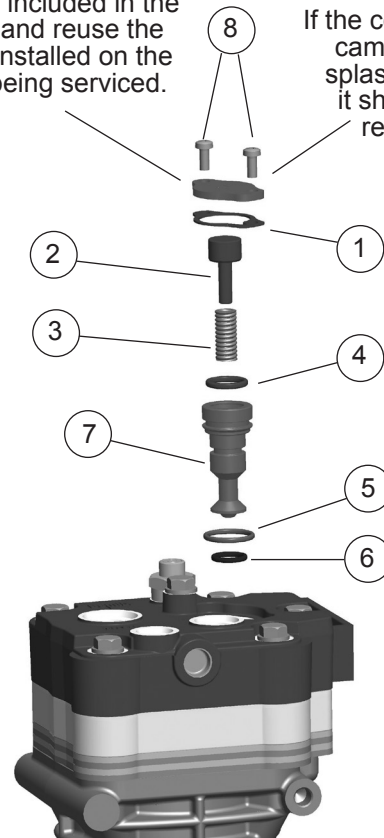

Unloader Kit Contents (services 1 unloader)
One kit is needed for BA-921 compressors.
Two kits are needed for BA-922 compressors.

Item No.	Description	Qty.
1	Gasket	1
2	Balance Piston	1
3	Balance Piston Spring	1
4	O-ring	1
5	O-ring	1
6	O-ring	1
7	Unloader Piston	1
8	Cap Screw	2
9	Lubricant (not shown)	1

Figure 1 – Unloader Kit Installation Exploded View (Bendix® BA-921® Compressor Shown)



The unloader service kit may include an unloader cap. Discard this cap from the kit and use the unloader cap(s) from the compressor being serviced.

THE VEHICLE PREPARATION

These instructions are general and are intended to be a guide. In some cases additional preparations and precautions are necessary. In all cases follow the instructions contained in the vehicle maintenance manual in lieu of the instructions, precautions, and procedures presented in this document.

1. Block the wheels of the vehicle and drain the air pressure from all the reservoirs in the system.
2. Remove as much road dirt and grease from the exterior of the compressor as possible.

GENERAL SAFETY GUIDELINES



WARNING! PLEASE READ AND FOLLOW THESE INSTRUCTIONS

TO AVOID PERSONAL INJURY OR DEATH:

When working on or around a vehicle, the following guidelines should be observed AT ALL TIMES:

- ▲ Park the vehicle on a level surface, apply the parking brakes and always block the wheels. Always wear personal protection equipment.
- ▲ Stop the engine and remove the ignition key when working under or around the vehicle. When working in the engine compartment, the engine should be shut off and the ignition key should be removed. Where circumstances require that the engine be in operation, **EXTREME CAUTION** should be used to prevent personal injury resulting from contact with moving, rotating, leaking, heated or electrically-charged components.
- ▲ Do not attempt to install, remove, disassemble or assemble a component until you have read, and thoroughly understand, the recommended procedures. Use only the proper tools and observe all precautions pertaining to use of those tools.
- ▲ If the work is being performed on the vehicle's air brake system, or any auxiliary pressurized air systems, make certain to drain the air pressure from all reservoirs before beginning ANY work on the vehicle. If the vehicle is equipped with a Bendix® AD-IS® air dryer system, a Bendix® DRM™ dryer reservoir module, or a Bendix® AD-9si® air dryer, be sure to drain the purge reservoir.
- ▲ Following the vehicle manufacturer's recommended procedures, deactivate the electrical system in a manner that safely removes all electrical power from the vehicle.
- ▲ Never exceed manufacturer's recommended pressures.
- ▲ Never connect or disconnect a hose or line containing pressure; it may whip and/or cause hazardous airborne dust and dirt particles. Wear eye protection. Slowly open connections with care, and verify that no pressure is present. Never remove a component or plug unless you are certain all system pressure has been depleted.
- ▲ Use only genuine Bendix® brand replacement parts, components and kits. Replacement hardware, tubing, hose, fittings, wiring, etc. must be of equivalent size, type and strength as original equipment and be designed specifically for such applications and systems.
- ▲ Components with stripped threads or damaged parts should be replaced rather than repaired. Do not attempt repairs requiring machining or welding unless specifically stated and approved by the vehicle and component manufacturer.
- ▲ Prior to returning the vehicle to service, make certain all components and systems are restored to their proper operating condition.
- ▲ For vehicles with Automatic Traction Control (ATC), the ATC function must be disabled (ATC indicator lamp should be ON) prior to performing any vehicle maintenance where one or more wheels on a drive axle are lifted off the ground and moving.
- ▲ The power **MUST** be temporarily disconnected from the radar sensor whenever any tests **USING A DYNAMOMETER** are conducted on a vehicle equipped with a Bendix® Wingman® system.
- ▲ You should consult the vehicle manufacturer's operating and service manuals, and any related literature, in conjunction with the Guidelines above.

INSTALLING UNLOADER KIT

(Note: Two unloader kits are required to service a Bendix® BA-922® compressor).

Refer to Figure 1 throughout removal and installation.

1. Read and follow the General Safety Guidelines.
2. Locate the two cap screws (8) that secure the unloader cap to the cylinder head and remove any remaining contamination in the area to prevent it from entering the unloader bore.
3. To restrain the spring force exerted by balance piston spring (3), hold the unloader cap in place while removing the two screws. Carefully release the hold on the unloader cap until the spring force is relaxed, then remove the unloader cap (and splash shield for the single cylinder compressor, if present).
Note: Retain the original unloader cap(s) and splash shield (if present). These parts will be re-used.
4. Remove and discard the unloader cover gasket (1).
5. Remove and discard the balance piston (2) and balance piston spring (3) from the cylinder head. Then remove and discard the unloader piston (7) along with its three o-rings (4, 5, & 6).
6. Clean the unloader piston bore in the cylinder head.
7. When installing o-rings, take special care to thoroughly lubricate and install without twisting or pinching them during installation. If an o-ring appears to be twisted, manipulate to remove any twists.
Using the lubricant provided (9), thoroughly lubricate and install the o-rings (4, 5, & 6) on the unloader piston (7) and lubricate the unloader piston bore in the cylinder head. Insert the unloader piston (7) with o-rings installed into the head.
Note: The largest and smallest diameter o-rings (5 & 6) are installed on the outside of the piston (7).
8. Insert the balance piston spring (3) into the unloader piston (7).
9. Lubricate the balance piston (2) and insert the piston, small diameter first, into the balance piston spring (3) previously installed in the unloader piston (7).
10. **Note:** For both single and twin cylinder compressors, the original unloader caps must be re-used to service the compressors. Discard the unloader caps supplied with the service kit (if included). If the single cylinder compressor being serviced came with a splash shield, it should be re-used. Clean any of the gasket material from the unloader caps. If the unloader cap used on the single cylinder compressor has a thin, narrow machined slot, remove any debris if present in the slot before reusing it.

- Position the unloader cap gasket (1) on the cylinder head. Position the unloader cap (and splash shield for the single cylinder compressor) on top of the balance piston (2) making certain the cap is oriented correctly. Using manual pressure, gently push the balance piston into the unloader piston until the unloader cap rests against the cylinder head. Secure the unloader cap using the two cap screws (8). Torque to 62-71 in-lbs.
- Follow the steps under the Returning the Vehicle to Service section.

RETURNING THE VEHICLE TO SERVICE

- Install any fittings, etc., if applicable, in the same position on the compressor noted and marked during disassembly. Make certain the threads are clean and the fittings are free of corrosion. Replace as necessary. *See the Torque Specifications in this document for various fitting sizes and thread types.*
- Before returning the vehicle to service, perform the Operation and Leakage Tests specified below. Pay particular attention to all lines and check for air, oil, and coolant leaks at compressor connections. Also check for noisy operation and repair or replace components as needed.

OPERATION & LEAKAGE TESTS

- Start the engine and note that air system steadily builds pressure.
- With system air pressure increasing, check for cylinder head gasket air leakage. Apply a soap solution around the cylinder head. Check the gaskets between the cylinder head, cooling plate, and valve plate assembly for air leakage. No leakage is permitted.
If leakage is detected, try re-torquing the head bolts after draining all air pressure. Replace the compressor if replacing the head gasket has not resolved the leakage problem.
- Allow air system pressure to build and note that the compressor unloads properly at the specified governor cut-out pressure. Repeat this test three (3) times, noting that the compressor unloads at approximately the same pressure each time. If the compressor fails to unload by at least 150 psi system pressure, check all air lines to and from the governor. Make certain each line is clear (unobstructed) and not kinked, or leaking. Repair or replace the governor as needed.
- More complete compressor performance tests are provided in the Bendix Service Data sheet. This publication is available online at bendix.com or by calling 1-800-AIR-BRAKE (1-800-247-2725).

TORQUE SPECIFICATIONS

Bolt, Fitting, Nut, or Screw	Assembly Torque
	(in-lbs)
Cylinder Head	
M8x1.25-6g	265-292
Inlet Port Fittings	
1-3/16" - 12	575-637
1" - 12-1/2 NPT	1.5-2.5 TFFT ¹
Discharge Port Fittings	
7/8"-14 UNF	460-504
3/4"-14 NPT	2-3 TFFT ¹
Water Port Fittings	
3/4"-16 UNF	319-345
3/8"-18 NPT	2-3 TFFT ¹
Unloader Port Fittings	
1/8"-27 NPT	2-3 TFFT ¹
Safety Valve Port	
3/4"-16 UNF	319-345
1/2"-14 NPT	2-3 TFFT ¹
Oil Port	
7/16"-16 UNF	97-115

¹Note: TFFT = Turns From Finger Tight

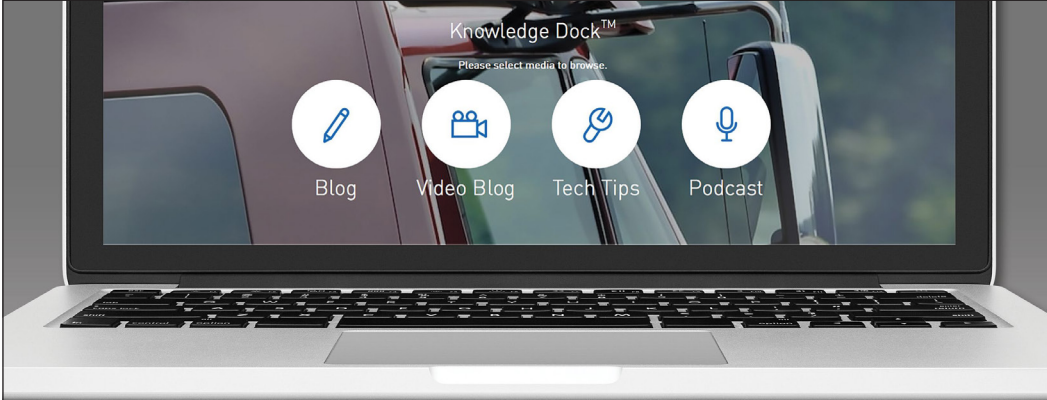

Knowledge Dock™
Please select media to browse.

Blog Video Blog Tech Tips Podcast

Trucking moves fast. Move faster.
Knowledge Dock™
• BLOGS • PODCASTS • VIDEOS • 24/7/365
[knowledge-dock.com]



Log-on and Learn from the Best
On-line training that's available when you are—24/7/365.
Visit www.brake-school.com.