

# Installation Instructions



## BENDIX® COMPRESSOR REAR ADAPTER KIT

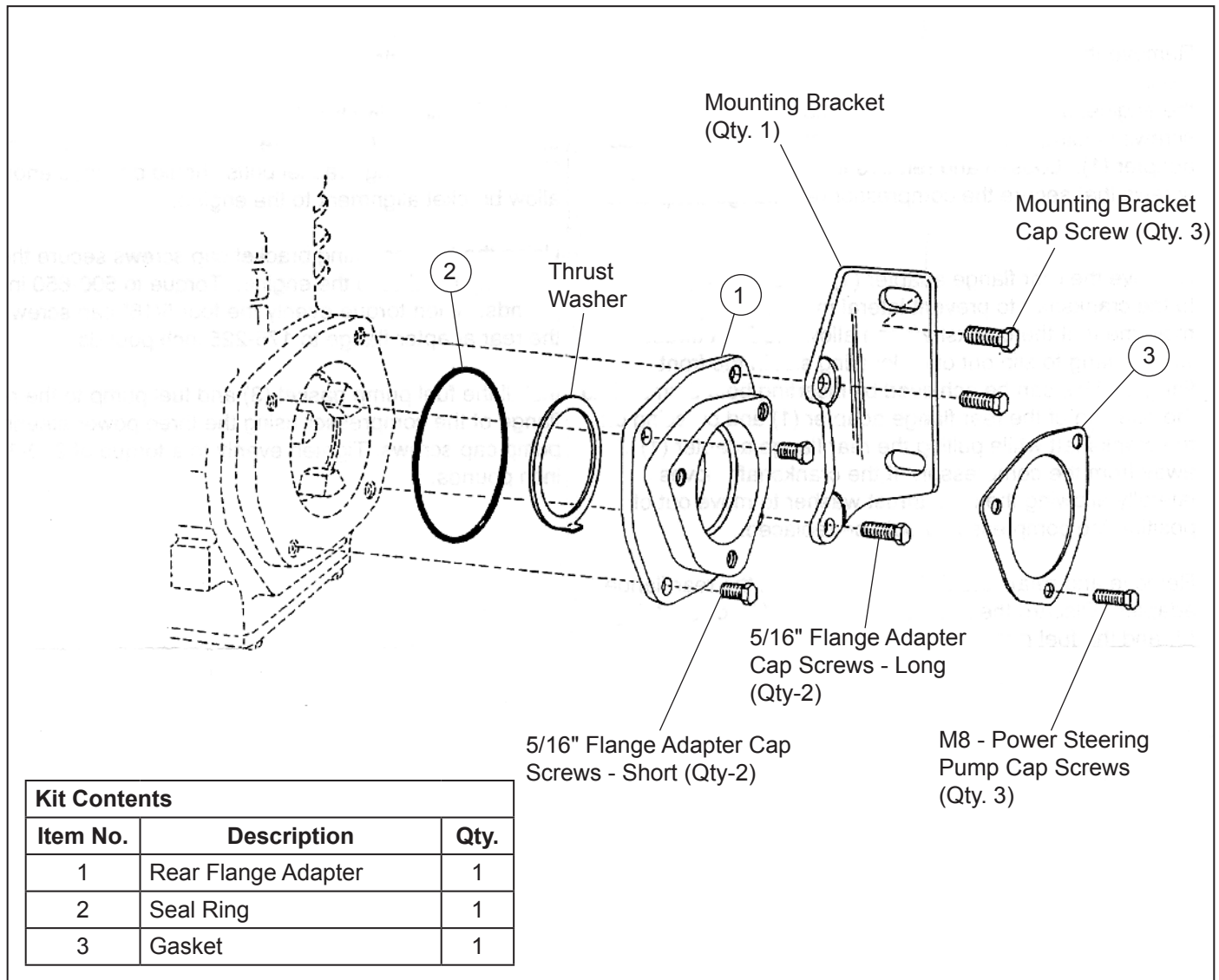

Figure 1 – Bendix® Compressor Rear Adapter Kit Contents

### DISASSEMBLY

1. Remove road dirt and grease from the exterior of the compressor with a cleaning solvent.
2. Remove the three flange cap screws which are used to secure the fuel pump to the rear flange of the compressor. Without disconnecting any hoses, move the fuel pump away from the compressor.
3. Remove the compressor mounting bracket by first removing the two cap screws that secure the mounting bracket to the engine, and then loosen and remove the two cap screws holding the bracket to the compressor rear flange adapter (1). Loosen and remove the remaining two cap screws that secure the compressor rear flange adapter to the compressor.
4. Remove the rear flange adapter (1) while applying pressure to the crankshaft to prevent lateral movement. (Lateral movement of the crankshaft can allow the front thrust washer tang to slip out of its locating slot in the front flange.) This can be achieved by inserting both thumbs into the opening of the rear flange adapter (1) and pressing on the crankshaft while pulling the rear flange adapter (1) away from the compressor. If the crankshaft moves laterally allowing the front thrust washer to move out of position, the compressor should be replaced.
5. Remove and retain the thrust washer from the rear flange adapter. Discard the rear flange adapter (1), oil seal ring (2), and the fuel pump gasket (3).

## GENERAL SAFETY GUIDELINES



**WARNING! PLEASE READ AND FOLLOW THESE INSTRUCTIONS**

**TO AVOID PERSONAL INJURY OR DEATH:**

**When working on or around a vehicle, the following guidelines should be observed AT ALL TIMES:**

- ▲ Park the vehicle on a level surface, apply the parking brakes and always block the wheels. Always wear personal protection equipment.
- ▲ Stop the engine and remove the ignition key when working under or around the vehicle. When working in the engine compartment, the engine should be shut off and the ignition key should be removed. Where circumstances require that the engine be in operation, **EXTREME CAUTION** should be used to prevent personal injury resulting from contact with moving, rotating, leaking, heated or electrically-charged components.
- ▲ Do not attempt to install, remove, disassemble or assemble a component until you have read, and thoroughly understand, the recommended procedures. Use only the proper tools and observe all precautions pertaining to use of those tools.
- ▲ If the work is being performed on the vehicle's air brake system, or any auxiliary pressurized air systems, make certain to drain the air pressure from all reservoirs before beginning ANY work on the vehicle. If the vehicle is equipped with a Bendix® AD-IS® air dryer system, a Bendix® DRM™ dryer reservoir module, or a Bendix® AD-9si® air dryer, be sure to drain the purge reservoir.
- ▲ Following the vehicle manufacturer's recommended procedures, deactivate the electrical system in a manner that safely removes all electrical power from the vehicle.
- ▲ Never exceed manufacturer's recommended pressures.
- ▲ Never connect or disconnect a hose or line containing pressure; it may whip and/or cause hazardous airborne dust and dirt particles. Wear eye protection. Slowly open connections with care, and verify that no pressure is present. Never remove a component or plug unless you are certain all system pressure has been depleted.
- ▲ Use only genuine Bendix® brand replacement parts, components and kits. Replacement hardware, tubing, hose, fittings, wiring, etc. must be of equivalent size, type and strength as original equipment and be designed specifically for such applications and systems.
- ▲ Components with stripped threads or damaged parts should be replaced rather than repaired. Do not attempt repairs requiring machining or welding unless specifically stated and approved by the vehicle and component manufacturer.
- ▲ Prior to returning the vehicle to service, make certain all components and systems are restored to their proper operating condition.
- ▲ For vehicles with Automatic Traction Control (ATC), the ATC function must be disabled (ATC indicator lamp should be ON) prior to performing any vehicle maintenance where one or more wheels on a drive axle are lifted off the ground and moving.
- ▲ The power **MUST** be temporarily disconnected from the radar sensor whenever any tests **USING A DYNAMOMETER** are conducted on a vehicle equipped with a Bendix® Wingman® system.
- ▲ You should consult the vehicle manufacturer's operating and service manuals, and any related literature, in conjunction with the Guidelines above.

## ASSEMBLY

Use the removed hardware and the contents of the kit.

1. Place the oil seal ring (2) into the groove on the rear flange adapter (1).
2. Insert the tab of the thrust washer into the rear flange adapter (1) and install the adapter on the compressor making sure not to pinch the oil seal ring (2). Be sure to align the rear flange adapter with the fuel pump.
3. Fasten the rear flange adapter (1) to the compressor with the two shorter 5/16" cap screws in the left two holes.
4. Attach the mounting bracket to the rear flange adapter with the two longer 5/16" cap screws. Snug all four cap screws. Note, the mounting bracket bolts should be loose enough to allow bracket alignment to the engine.
5. Using the two mounting bracket cap screws, secure the mounting bracket to the engine. Torque to 500-650 in-lbs. Then torque evenly the four 5/16" cap screws for the rear adapter flange to 175-225 in-lbs.
6. Install the fuel pump gasket (3) and fuel pump to the rear flange of the compressor using the three power steering pump cap screws. Tighten evenly to a torque of 260-340 in-lbs.

Trucking moves fast. Move faster.

**Knowledge Dock™**

• BLOGS • PODCASTS • VIDEOS • 24/7/365

[knowledge-dock.com](http://knowledge-dock.com)

# Bendix®

**Log-on and Learn from the Best**

On-line training that's available when you are—24/7/365.  
Visit [www.brake-school.com](http://www.brake-school.com).