

Technical Bulletin



Bulletin No: TCH-001-059

Effective Date: 10-20-2010

Cancels: N/A

Page: 1 of 2

Subject: Pulley-Driven Compressor Mounting Position

Bendix® Tu-Flo® 550 pulley-driven, base-mounted compressors installed on certain Navistar® V-8 engines may have a metal tag under the front-left mounting bolt, as shown below. If the compressor with this metal tag is removed during engine service, please use the following procedure to re-install the compressor. (Note: this procedure does not apply if replacing the compressor with a different unit.)

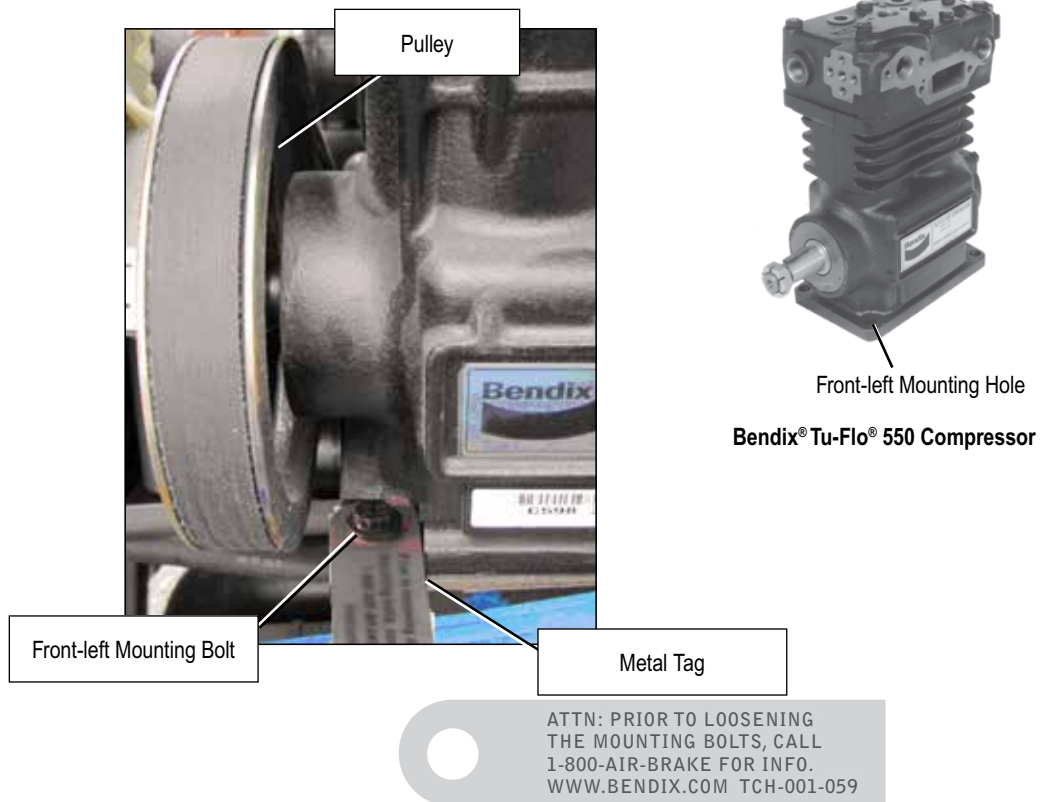

ATTN: PRIOR TO LOOSENING
THE MOUNTING BOLTS, CALL
1-800-AIR-BRAKE FOR INFO.
WWW.BENDIX.COM TCH-001-059

BENDIX® TU-FLO® 550 COMPRESSOR RE-INSTALLATION PROCEDURE

Be sure to follow all safety guidelines outlined in the Bendix® Tu-Flo® 550 Compressor Service Data Sheet SD-01-337 before performing any maintenance procedures.

1. Clean the bottom surface of the Tu-Flo® 550 compressor and top surface of the compressor mounting bracket.
2. Install a new gasket between the compressor and the compressor mounting bracket as specified by the OEM.

Continued...

3. Mount the compressor and mounting gasket on the compressor mounting bracket and loosely install the four (4) compressor (M10) mounting bolts previously removed.
4. Using a feeler gauge, measure the distance between the shoulder of the front-left mounting bolt and the front flange of the compressor, as shown below.

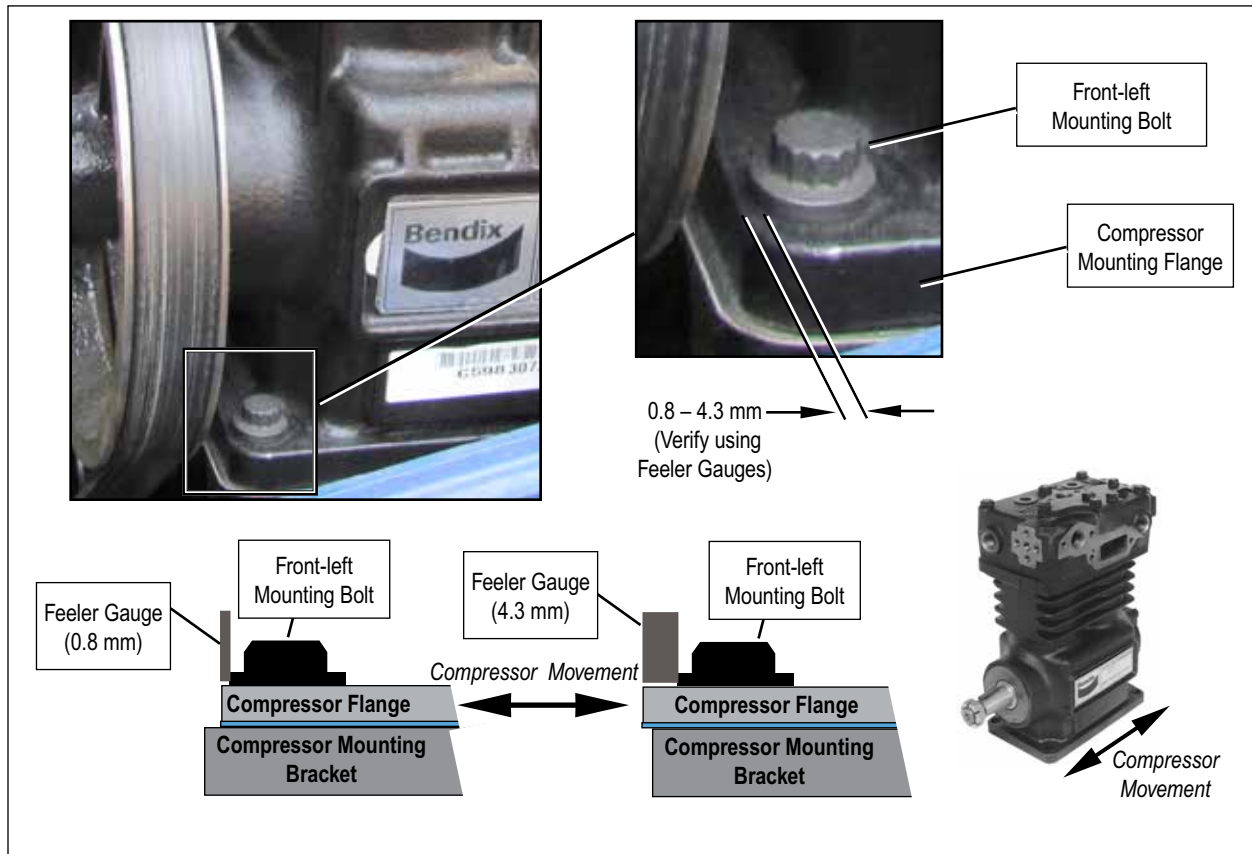

5. Move the compressor toward the front (pulley side) or back until a feeler gauge reading between 0.8 and 4.3 mm is reached.
6. Using the torque specified by the OEM, tighten three (3) of the mounting bolts, leaving the front-left mounting bolt loose.
7. Remove the front-left mounting bolt and re-install the metal tag in its original location under the front-left mounting bolt.
8. Tighten the front-left mounting bolt using the same OEM specified torque used on the other three mounting bolts.
9. Follow the Service Data Sheet, SD-01-337, for “Testing Rebuilt Compressor” before placing the vehicle into service.

