

BENDIX® ESM™ PREVENTIVE MAINTENANCE KIT

Proper maintenance during regular service intervals is key to ensuring an air compressor functions at its best. The same is true for an Electric Screw Module (ESM™). That's why Bendix is here to make that maintenance as easy as possible with the **Bendix® ESM™ Preventive Maintenance Kit (Bendix® PN K263406)**.



Help Keep Your Electric Screw Module (ESM™) Operating in Peak Condition

Maintenance utilizing the Bendix® ESM™ Preventive Maintenance Kit (PN K263406) must be performed according to the following chart:*

Description	ESM1 & ESM2
Compressor Operating Duration	One year or 1,500 hours (whichever comes first)
Oil Type	Chevron Cetus PAO 46 or Castrol Alphasyn® T46
Oil Quantity (liters) (including oil separator & oil cooler)	1.2

*Maintenance Includes:

- Oil change: Chevron Cetus® PAO 46 (sold separately) is available from Bendix (**PN K250712**).
- New oil coalescing cartridge.
- New air filter element.
- Visual inspection of the module components (worn wiring, leakages, etc.).



All of the insulation components removed during maintenance must be properly re-installed and secured after component servicing. Some parts, such as clips, may need to be replaced.



Use genuine Bendix® parts during service intervals to ensure safe and proper use, as well as to maintain warranty coverage.

Bendix® ESM™ Preventive Maintenance Kit Contents

Electric Screw Module (ESM™2)

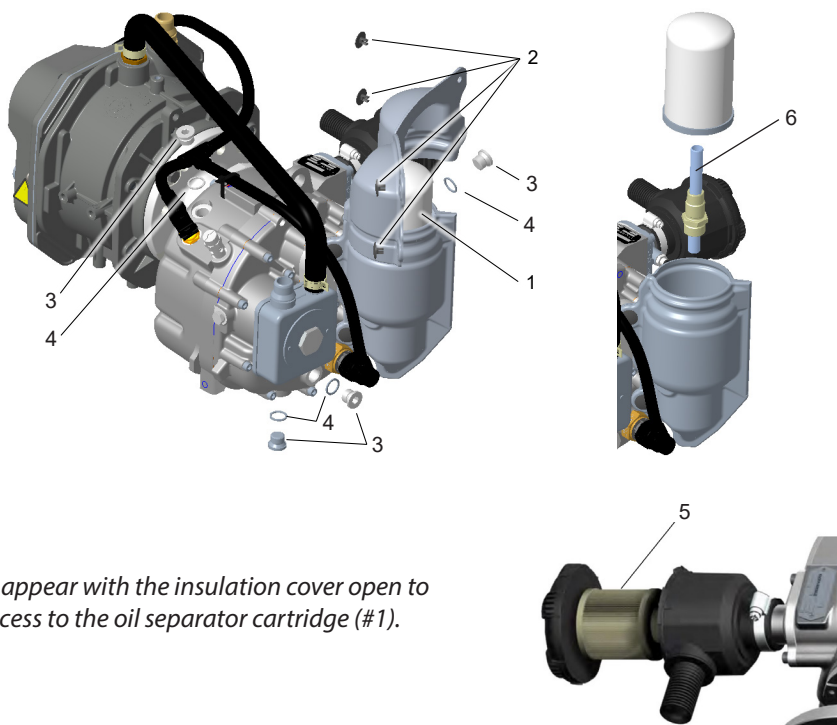

Pictures appear with the insulation cover open to show access to the oil separator cartridge (#1).

Position	Component	Quantity
1**	Oil Separator Cartridge	1
2	Clip	8
3	Oil Plug	4
4	Sealing Ring	4
5**	Air Filter Element	1
6**	Tube	1

Bendix® ESM™ Preventive Maintenance Kit (PN K263406) includes all of the components listed in the chart above.

***Components 1, 5, and 6 must be serviced, along with a complete oil change, per the original equipment maintenance schedule. Failure to complete proper maintenance may result in damage to vehicle components or systems.*



For more information, contact your Bendix Account Manager.

