



Installation Instructions

MC-11 ANTILOCK ASSEMBLY

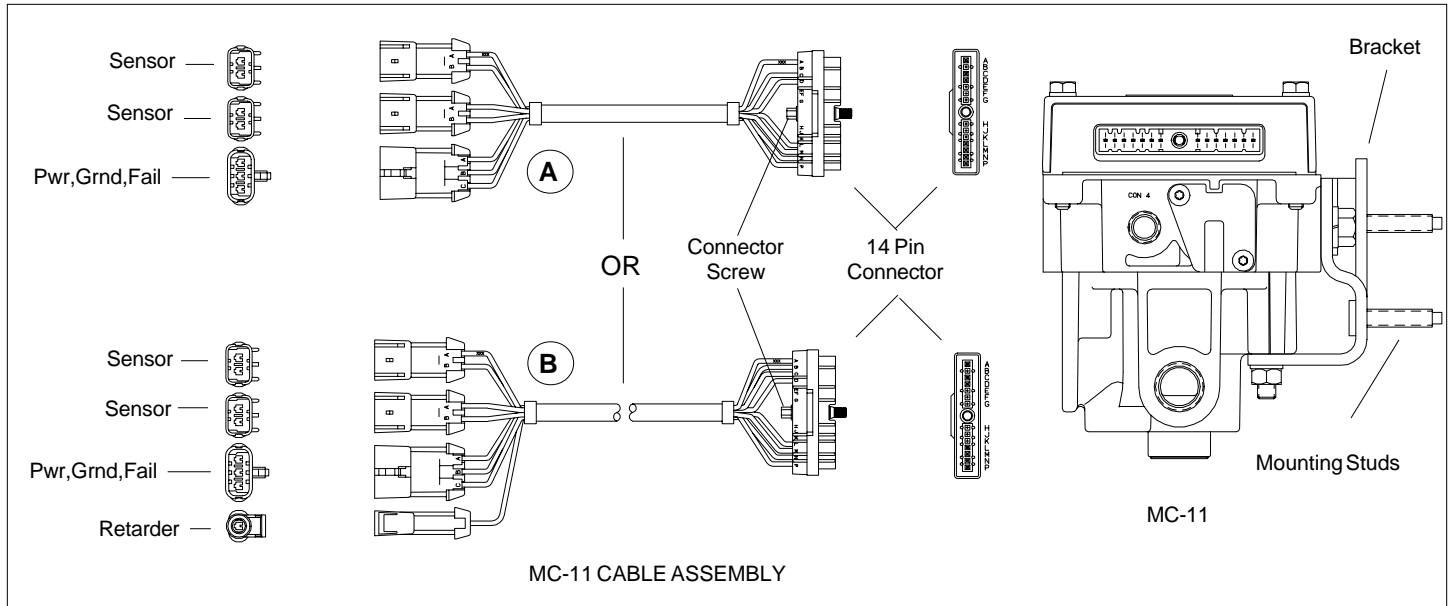

FIGURE 1 - MC-11 INSTALLATION

IMPORTANT! PLEASE READ AND FOLLOW THESE INSTRUCTIONS TO AVOID PERSONAL INJURY OR DEATH:

When working on or around a vehicle, the following general precautions should be observed at all times.

1. Park the vehicle on a level surface, apply the parking brakes, and always block the wheels.
2. Stop the engine when working around the vehicle.
3. If the vehicle is equipped with air brakes, make certain to drain the air pressure from all reservoirs before beginning ANY work on the vehicle.
4. Following the vehicle manufacturer's recommended procedures, deactivate the electrical system in manner that removes all electrical power from the vehicle.
5. When working in the engine compartment the engine should be shut off. Where circumstances require that the engine be in operation, **EXTREME CAUTION** should be used to prevent personal injury resulting from contact with moving, rotating, leaking, heated, or electrically charged components.
6. Never connect or disconnect a hose or line containing pressure; it may whip. Never remove a component or plug unless you are certain all system pressure has been depleted.
7. Never exceed recommended pressures and always wear safety glasses.
8. Do not attempt to install, remove, disassemble or assemble a component until you have read and thoroughly understand the recommended procedures. Use only the proper tools and observe all precautions pertaining to use of those tools.
9. Use only genuine Bendix replacement parts, components, and kits. Replacement hardware, tubing, hose, fittings, etc. should be of equivalent size, type, and strength as original equipment and be designed specifically for such applications and systems.
10. Components with stripped threads or damaged parts should be replaced rather than repaired. Repairs requiring machining or welding should not be attempted unless specifically approved and stated by the vehicle or component manufacturer.
11. Prior to returning the vehicle to service, make certain all components and systems are restored to their proper operating condition.

MC-11 REMOVAL

1. Identify and mark or label all air lines connected to the MC-11.
2. Disconnect air lines and fittings.
3. Disconnect the 14-pin connector by loosening its hex screw.
4. Remove the MC-11 from the vehicle.

INSPECTION

Look for any visible damage to the connectors, wiring harnesses, air line fittings and mounting hardware. Repair or replace any damaged components.

MC-11 INSTALLATION

1. Install the air line fittings in the appropriate ports, as identified during "MC-11 REMOVAL."
2. Install the MC-11 on the vehicle.
3. Connect air lines to their appropriate ports, as defined in "MC-11 REMOVAL."
4. Refer to Figure 1 when installing the MC-11 cable assembly. Vehicles without a retarder use cable assembly "A," and vehicles with a retarder use cable assembly "B."
5. Install the 14-pin connector into the electronic controller and secure with its hex screw.

TEST

Before placing the vehicle back in service, test the AntiLock system according to MC-11 Troubleshooting Instructions S-1112.